

## PMI.PMP.v2022-05-07.q999

<b>Exam Code:</b>	PMP
<b>Exam Name:</b>	Project Management Professional (2025 Version)
<b>Certification Provider:</b>	PMI
<b>Free Question Number:</b>	999
<b>Version:</b>	v2022-05-07
<b># of views:</b>	15867
<b># of Questions views:</b>	9990
<a href="https://www.freeqas.com/qa/PMI/PMP/PMI.PMP.v2022-05-07.q999.html">https://www.freeqas.com/qa/PMI/PMP/PMI.PMP.v2022-05-07.q999.html</a>	

### NEW QUESTION: 1

The project management executing processes include all of the following EXCEPT:

- A. Select sellers, cost budgeting
- B. Inform distribution, Request Sellers Responses
- C. None of the choices are correct
- D. Perform Quality Assurance, Develop Project Team

**Answer: A (LEAVE A REPLY)**

### NEW QUESTION: 2

A project manager is creating a program evaluation and review technique (PERT) diagram. A primary activity on the critical path has a most optimistic time of three weeks, a most pessimistic time of seven weeks, and a most likely time of five weeks.

What is the activity's expected time?

- A. 3 weeks
- B. 5 weeks
- C. 6 weeks
- D. 7 weeks

**Answer: B (LEAVE A REPLY)**

Section: Executing

### NEW QUESTION: 3

In an organization with a projectized organizational structure, who controls the project budget?

- A. Functional manager
- B. Project manager
- C. Program manager
- D. Project management office

**Answer: B (LEAVE A REPLY)**

Section: Planning

Explanation/Reference:

**NEW QUESTION: 4**

A project has been stopped during the execution phase because the construction methods are not in compliance with environmental regulations. The project manager was not aware of the environmental requirements of the project and now needs advice on how to deal with environmental compliance in future projects.

What should the project manager do to avoid a similar situation in future projects?

- A. Collect project requirements during the initiation phase in every project.
- B. Plan to complete regulatory work within budget and on schedule.
- C. Update the schedule every two weeks during the execution phase
- D. Use expert judgment when dealing with environmental requirements.

**Answer: A ([LEAVE A REPLY](#))**

**NEW QUESTION: 5**

Which tools or techniques are not used in Sequence Activities?

- A. Expert judgment
- B. Network templates
- C. Arrow diagramming method (ADM)
- D. Precedence diagramming method (PDM)

**Answer: ([SHOW ANSWER](#))**

Expert judgment is not used in Sequence Activities. Sequence Activities: Identifying and documenting interactivity logical relationships.

**NEW QUESTION: 6**

Which type of contract gives both the seller and the buyer flexibility to deviate from performance with financial incentives?

- A. Cost Plus Award Re (CPAF)
- B. Fixed Price Incentive Fee (FPIF)
- C. Cost Plus Incentive Fee (CPIF)
- D. Time and Material (T&M)

**Answer: B ([LEAVE A REPLY](#))**

**NEW QUESTION: 7**

Your project's primary constraint is quality. To make certain the project team members don't feel too pressed for time and to avoid schedule risk, which of the following tools does not take into consideration risks when estimating the duration of project activities?

- A. Beta
- B. Bottom-up estimating
- C. Triangular

D. Analogous estimating

**Answer:** ([SHOW ANSWER](#))

**NEW QUESTION: 8**

An agile project manager is leading a large systems modernization project that is midway through its third iteration. Two project team members are replaced which results in a drop in the team's productivity. What should have been done to avoid this situation?

- A. The new team members should have
- B. The new team members should have had sufficient training
- C. The new team members should have received coaching and mentoring from the project manager
- D. The new team members should have been properly integrated into the team

**Answer:** A ([LEAVE A REPLY](#))

**NEW QUESTION: 9**

The use of quality circles:

- A. 1) Has proven ineffective in both Japan and the U.S. and 2) is particularly effective in overcoming labor/management conflicts.
- B. has proven ineffective in both Japan and the U.S.
- C. allows workers the opportunity to generate solutions for chronic quality problems.
- D. is particularly effective in overcoming labor/management conflicts.
- E. provides a quick fix for most quality problems.

**Answer:** C ([LEAVE A REPLY](#))

**NEW QUESTION: 10**

You have been hired as a contract project manager for Grapevine Vineyards. Grapevine wants you to design an Internet wine club for its customers. Customers must register before being allowed to order wine over the Internet so that legal age can be established. You know that the module to verify registration must be written and tested using data from Grapevine's existing database. This new module cannot be tested until the data from the existing system is loaded. You are going to hire a vendor to perform the programming and testing tasks for this module to help speed up the project schedule. Since they'll have access to your customer list and potentially other trade secrets, you'll ask them to sign a nondisclosure agreement. This is an example of which of the following?

- A. Procurement documents
- B. Standard form
- C. Organizational process asset
- D. Fixed cost contract

**Answer:** B ([LEAVE A REPLY](#))

Standard forms are a tool and technique of the Plan Contracting process. Standard forms can be nondisclosure agreements, standardized contracts, and so on.

**NEW QUESTION: 11**

The following is a network diagram for a project.

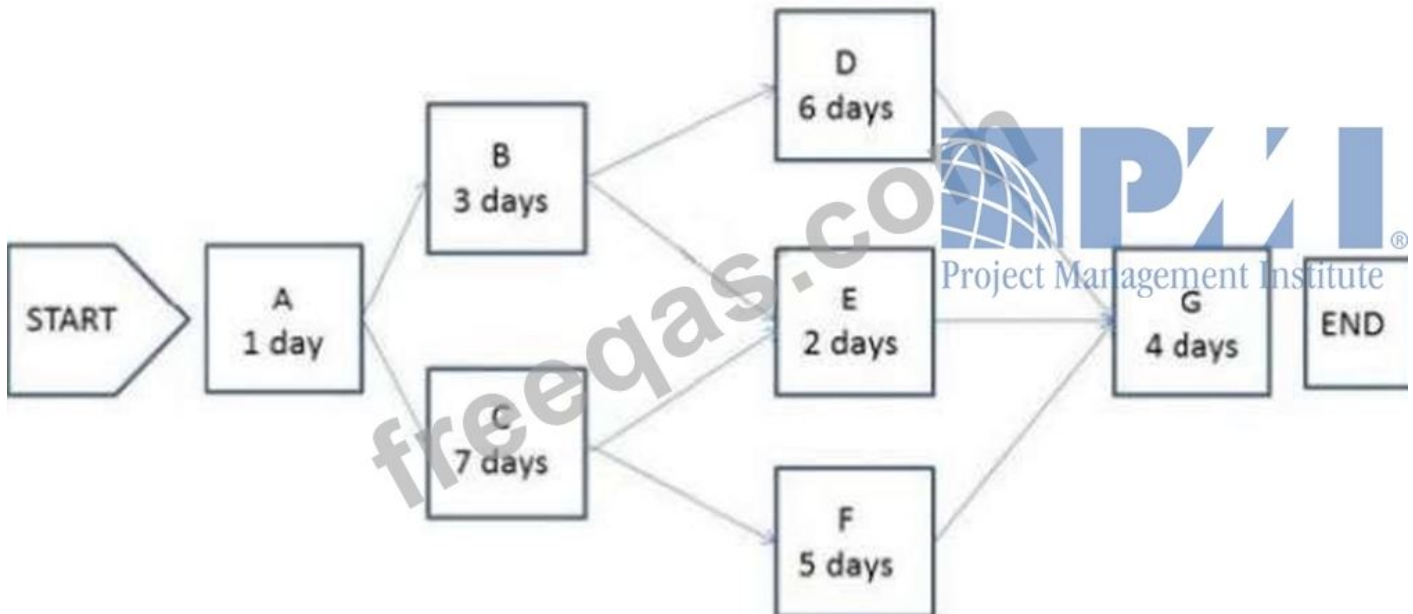

What is the critical path for the project?

- A. A-B-D-G
- B. A-B-E-G
- C. A-C-F-G
- D. A-C-E-G

**Answer: C** ([LEAVE A REPLY](#))

Section: Planning

**NEW QUESTION: 12**

Stock options, assigned parking spaces and a company car are all examples of what?

- A. Ways to justify paying a lower salary
- B. Leverage to encourage better performance
- C. Perks associated with functional management
- D. Non-monetary rewards

**Answer: D** ([LEAVE A REPLY](#))

**NEW QUESTION: 13**

The Perform Quality Assurance process occurs in which Process Group?

- A. Executing
- B. Monitoring and Controlling
- C. Initiating
- D. Planning

**Answer: A** ([LEAVE A REPLY](#))

**NEW QUESTION: 14**

Which of the following best describes the amount of time one can delay the start of a task without delaying the start of a successor task?

- A. Lag time
- B. Lead time
- C. Free slack
- D. None of the choices are correct
- E. Total slack

**Answer: C** ([LEAVE A REPLY](#))

#### **NEW QUESTION: 15**

A project's earned value (EV) report indicates that an activity's cost variance (CV) is -5,000 and its schedule variance (SV) is 1,000. What is the status of this activity?

- A. Behind schedule and over budget
- B. On schedule and within budget
- C. Behind schedule and within budget
- D. Ahead of schedule and over budget

**Answer: D** ([LEAVE A REPLY](#))

Section: Monitoring and Controlling

#### **NEW QUESTION: 16**

During the final stages of project execution, a dissatisfied customer requests that a feature be removed. The request is approved and will help complete the project on time.

What should the project manager do next?

- A. Review the changes with the project team.
- B. Revise the communications management plan.
- C. Reduce project resources to decrease costs.
- D. Update the project scope baseline.

**Answer: A** ([LEAVE A REPLY](#))

Section: Closing

**Valid PMP Dumps** shared by PrepPdf.com for Helping Passing PMP Exam! PrepPdf.com now offer the **newest PMP exam dumps**, the PrepPdf.com PMP exam **questions have been updated** and **answers have been corrected** get the **newest** PrepPdf.com PMP dumps with Test Engine here: <https://www.preppdf.com/PMI/PMP-prepaway-exam-dumps.html> (2045 Q&As Dumps, **40%OFF Special Discount: Exam-Tests**)

#### **NEW QUESTION: 17**

A company plans to set up a new product that is unlike any previous product they have developed. The project manager must manage customer expectations.

What should the project manager do to identify the project's deliverables?

- A. Use their knowledge and expertise.
- B. Capture deliverables in the project charter and receive approval.
- C. Discuss options with the project sponsor.
- D. Meet with the project team to decide on the deliverables based on the budget.

**Answer: B ([LEAVE A REPLY](#))**

Section: Initiation

#### **NEW QUESTION: 18**

A product owner is invited to a sprint review meeting. At the end of the review, the product owner says that the increment is ready to be delivered to the customer.

What conclusion should the project manager come to with regard to the product owner's statement?

- A. The product owner trusts the team and is marking the product as complete.
- B. The product owner has evaluated the product against the definition of done (DoD).
- C. The product owner does not have visibility into what the team has done in the product increment.
- D. The product owner will release the product to customers without showing them a demo.

**Answer: ([SHOW ANSWER](#))**

#### **NEW QUESTION: 19**

A project manager and project team have successfully implemented a new product line at their company and are in the process of closing it out. The project manager has obtained acceptance from the internal customer, conducted reviews, and documented lessons learned. What documentation should be created in order to complete the project?

- A. Final product and organizational process assets updates
- B. Project management plan updates and final product
- C. Cost performance baseline and final product
- D. Scope baseline and final product

**Answer: A ([LEAVE A REPLY](#))**

#### **NEW QUESTION: 20**

In which Knowledge Area is the project charter developed?

- A. Project Cost Management
- B. Project Scope Management
- C. Project Integration Management
- D. Project Time Management

**Answer: C ([LEAVE A REPLY](#))**

#### **NEW QUESTION: 21**

You are in the middle of a major new facility construction project. The structural steel is in place and the heating conduits are going into place when a senior manager informs you that he is worried that the project will not meet the quality standards. What should you do in this situation?

- A. Analogously estimate future results.
- B. Assure senior management that during the Plan Quality process it was determined that the project would meet the quality standards.
- C. Check the results from the last quality management plan.
- D. Form a quality assurance team.

**Answer:** ([SHOW ANSWER](#))

#### **NEW QUESTION: 22**

Which tool or technique is used in validating the scope of a project?

- A. Facilitated workshops
- B. Interviews
- C. Inspection
- D. Meetings

**Answer:** ([SHOW ANSWER](#))

Section: Monitoring and Controlling

#### **NEW QUESTION: 23**

Your project just completed, and one of your subcontractors has sent you floor seats to the next big hockey game to thank you for your business. What is the BEST way to respond?

- A. Ask for tickets for the entire team, so that it is fair to everyone
- B. Report the subcontractor to PMI
- C. Thank the subcontractor, but politely refuse the gift
- D. Thank the subcontractor, but do not give him preference in the next RFP

**Answer:** C ([LEAVE A REPLY](#))

The PMP Code of Professional Conduct says that you're not allowed to accept any kind of gift, not even if it's after the project has finished. That would be the same thing as taking a bribe.

#### **NEW QUESTION: 24**

What is the number of stakeholders, if the project has 28 potential communication channels?

- A. 7
- B. 8
- C. 14
- D. 16

**Answer:** B ([LEAVE A REPLY](#))

Section: Closing

#### **NEW QUESTION: 25**

You are putting together the final schedule on your security encryption project. The problem you are having is that you don't have a consistent usage of your resources. Some are working 2 hours a day, some 16 hours a day, and there are some days when they aren't scheduled to work at all. Which of the following below would fix this problem?

- A. Resource leveling
- B. PERT analysis
- C. Fast tracking
- D. Crashing

**Answer: ([SHOW ANSWER](#))**

Section: Mix Questions

#### **NEW QUESTION: 26**

CIP embodies which of the following principals?

- A. teamwork
- B. All of the other alternatives apply.
- C. constancy of purpose
- D. customer focus and involvement
- E. total involvement

**Answer: ([SHOW ANSWER](#))**

#### **NEW QUESTION: 27**

Expert judgment is a best practice as a tool and technique in many project management processes, and the list of possible sources for experts varies by the organization and by its association with others. One way once you have identified experts who you feel could be of assistance is to\_\_\_\_\_

- A. Use a focus group
- B. Review documentation
- C. Hold one-on-one interviews
- D. Conduct interviews

**Answer: A ([LEAVE A REPLY](#))**

Section: Mix Questions

Explanation:

The key word in the question was experts. Useful ways to obtain information from experts is to use a survey, such as a Delphi approach, or to use a focus group, an excellent approach to obtain insight into attitudes, useful to control stakeholder engagement.

#### **NEW QUESTION: 28**

The project manager has recently received funding approval for a training program for the entire project team but has not yet defined the most effective training course. One team member submitted a request for specialized training that is required for the project.

How should the project manager handle this request?

- A. Reject the request as it does not impact the project deliverables.
- B. Approve the request for the specialized training.
- C. Send this change request to the change control board (CCB) for approval.
- D. Validate if the training is within scope and budget.

**Answer:** ([SHOW ANSWER](#))

#### **NEW QUESTION: 29**

You are assigned as a project manager for an internal project. During cost planning and budgeting you found out, that there are peak times of costs during the project and other times when costs are fairly low. What could this mean for the project?

- A. You are a project manager and work with a lifecycle budget for your project. Fiscal budgets are a matter of the functional organization, and you have generally not to care about them.
- B. You may find another project manager with a project which has a different rhythm of high and low costs. Then, you may be able to move budget during one project's low cost periods to the other project.
- C. The fiscal budget mechanism which is used by the performing organization may not allow for cost peaks in your project, and you may have to smooth expenditures over time.
- D. You can silently create budget contingencies during low-cost periods and re-use them later during those periods when you have to cover peak levels in project costs.

**Answer:** C ([LEAVE A REPLY](#))

#### **NEW QUESTION: 30**

The project manager is given two teams that are restricted to working five days per week. The initial calculations give a project timeline of two weeks. However, one of the teams will only be available for two and a half days during week 1 due to a previous commitment. The timeline is revised to three weeks.

What optimization technique was used to revise the timeline?

- A. Critical chain management
- B. Critical path management
- C. Resource smoothing
- D. Resource leveling

**Answer:** B ([LEAVE A REPLY](#))

Section: Planning

#### **NEW QUESTION: 31**

Ensuring that projects and programs are reviewed to prioritize resource allocation is a focus of which of the following?

- A. Project management
- B. Program management
- C. Portfolio management
- D. Relationship management

**Answer: C (LEAVE A REPLY)**

Section: Monitoring and Controlling

**Valid PMP Dumps** shared by PrepPdf.com for Helping Passing PMP Exam! PrepPdf.com now offer the **newest PMP exam dumps**, the PrepPdf.com PMP exam **questions have been updated** and **answers have been corrected** get the **newest** PrepPdf.com PMP dumps with Test Engine here: <https://www.preppdf.com/PMI/PMP-prepaway-exam-dumps.html> (2045 Q&As Dumps, **40%OFF Special Discount: Exam-Tests**)

**NEW QUESTION: 32**

In which domain of project management would a Pareto chart provide useful information?

- A. Project Scope Management
- B. Project Communications Management
- C. Project Quality Management
- D. Project Time Management

**Answer: C (LEAVE A REPLY)**

**NEW QUESTION: 33**

A matrixed organization has a history of project schedule and cost overruns. A new project manager learns of this history and wants to avoid the trend. The project manager works with the project team to define, validate, and control all required work to complete the project successfully. What document is produced from this activity?

- A. Scope management plan
- B. Project management plan
- C. Project scope statement
- D. Project charter

**Answer: C (LEAVE A REPLY)**

**NEW QUESTION: 34**

The members of your project team have been assigned to your project with general availability levels of 50%.

Yesterday, they reported to you that significant variances occurred during project execution. You observed that the team members are spending less than 50% of their time working for your project. Your project schedule is on the way to become heavily delayed and deadlines are in jeopardy. What should you do?

- A. Focus on internal charges. Make sure that your project is not getting charged for more than the actual work.
- B. Talk to your sponsor and try to get more resources assigned on similar conditions as the existing ones.

**C.** Talk with the line managers. Negotiate clear and written assignments with predictable levels of effort.

**D.** Ignore the difficulties, adjust your schedule and negotiate new deadlines according to the slower progress.

**Answer: C** ([LEAVE A REPLY](#))

#### **NEW QUESTION: 35**

Halfway through project execution, stakeholders ask for equipment that was expected to be procured. The project manager explains that the equipment was purchased, but differs from what the stakeholders are currently asking for. This is because the initial requirements were changed during a previous meeting.

What should the project manager have done to avoid this situation?

**A.** Ensured project requirements were validated and communicated with the procurement team

**B.** Ensured changing stakeholder needs and requests were properly monitored

**C.** Ensured that communications were sent to all stakeholders when requirements change

**D.** Ensured procurement contracts were able to be canceled when situations like this arise

**Answer: C** ([LEAVE A REPLY](#))

#### **NEW QUESTION: 36**

A project manager is working on a multiphase networking project. Phase 1 is scheduled to finish next month.

Phase 2 is in the initiation phase and the budget approval

is past due. However, the project manager has a strategy in place for approval.

What should the project manager use to monitor this and help ensure a delay does not impact project performance?

**A.** Issue log

**B.** Change log

**C.** Assumption log

**D.** Action log

**Answer: D** ([LEAVE A REPLY](#))

#### **NEW QUESTION: 37**

A recent project took 12 months to complete; however, a new similar project is estimated to take 16 months to complete. What tool or technique should be used to match the timeline of the first project?

**A.** Monte Carlo simulation

**B.** Crashing

**C.** Quantitative risk analysis

**D.** Expert judgment

**Answer: B** ([LEAVE A REPLY](#))

**NEW QUESTION: 38**

A project manager must obtain approval for a network cabling project. After preparation of detailed project information, some team members remain dissatisfied, as the selected equipment is new and insufficiently tested. The project manager determines that the equipment meets technology needs.

What skills should the project manager use to obtain team consensus and sponsor approval?

- A. Interpersonal
- B. Team-building
- C. Stakeholder engagement
- D. Leadership

**Answer:** ([SHOW ANSWER](#))

Section: Initiation

**NEW QUESTION: 39**

What is the main output of Monitoring and Controlling?

- A. Project product
- B. Charter
- C. Corrective action
- D. Controlling stakeholders

**Answer:** C ([LEAVE A REPLY](#))

**NEW QUESTION: 40**

Which enterprise environmental factors are considered during cost estimating?

- A. Commercial databases and company structure
- B. Existing human resources and market place conditions
- C. Marketplace conditions and company structure
- D. Marketplace conditions and commercial databases

**Answer:** ([SHOW ANSWER](#))

**NEW QUESTION: 41**

Requirements for formal deliverable acceptance are defined in the \_\_\_\_\_

- A. Contract
- B. Procurement management plan
- C. Overall project management plan
- D. Specifications

**Answer:** ([SHOW ANSWER](#))

Section: Mix Questions

Explanation:

Two important components of any contract include what the buyer wants to buy and how the buyer defines acceptance of the products or services delivered. For contract closure to occur, deliverable acceptance must be completed.

**NEW QUESTION: 42**

Inputs to overall change control include:

- A. Project plan, performance reports, change requests
- B. Performance reports, performance measurement, change requests
- C. Project plan, change control system, performance measurement
- D. Change requests, performance measurement, project plan

**Answer: A ([LEAVE A REPLY](#))**

**NEW QUESTION: 43**

A project manager has a team of shared resources from other projects who are working on a client project Three days before the project is due. The team informs the project manager that the project will be delayed because a component was not delivered on time Competing priorities of the shared resources are delaying delivery of the component What should the project manager have done to prevent this delay from happening?

- A. Reorganized the team for the project based on the work breakdown structure (WBS)
- B. Updated the risk management plan and registered lessons learned for the project
- C. Used the resource management plan to identify the impacts of the other projects
- D. Maintained constant communication with the stakeholders of the other projects

**Answer: ([SHOW ANSWER](#))**

**NEW QUESTION: 44**

A company's board of directors announced that a major layoff will occur at the end of the month. When evaluating the impact the project manager found that 25% of the project team members are part of the layoff What should the project manager do first?

- A. Request a meeting with the customer and discuss trade-offs to reduce the scope and product quality as a result of the lack of personnel
- B. Request a meeting with the project sponsor to discuss the viability of the project and determine the next actions
- C. Request a meeting with the finance department to increase the budget of the project to hire temporary personnel to perform the affected activities
- D. Request a meeting with the human resources (HR) department and demand they find a solution to retain the project team members

**Answer: ([SHOW ANSWER](#))**

**NEW QUESTION: 45**

Consider the Project Integration Management knowledge area. Which of the following process are NOT included?

- A. Schedule Control
- B. Develop Project Management Plan
- C. Close Project

- D. Direct and Manage Project Execution
- E. Integrated Change Control

**Answer: A ([LEAVE A REPLY](#))**

**NEW QUESTION: 46**

When a project is undertaken to reduce defects in a product or service, the objective of the project is to create a/an:

- A. improvement
- B. program
- C. result
- D. portfolio

**Answer: ([SHOW ANSWER](#))**

Section: Initiation

**Valid PMP Dumps** shared by PrepPdf.com for Helping Passing PMP Exam! PrepPdf.com now offer the **newest PMP exam dumps**, the PrepPdf.com PMP exam **questions have been updated** and **answers have been corrected** get the **newest** PrepPdf.com PMP dumps with Test Engine here: <https://www.preppdf.com/PMI/PMP-prepaway-exam-dumps.html> (2045 Q&As Dumps, **40%OFF Special Discount: Exam-Tests**)

**NEW QUESTION: 47**

Which of the following statements are true regarding the communication process?

- A. None of the statement are true
- B. Receiver is responsible for making sure the information is clear and complete
- C. Sender is responsible for making sure the information is clear and complete
- D. Sender is responsible for making the information clear and complete

**Answer: D ([LEAVE A REPLY](#))**

**NEW QUESTION: 48**

A project manager needs stakeholder approval of the project plans in order to establish an execution baseline.

What should the project manager do?

- A. Attach all of the plans to an email and request feedback from stakeholders within a certain timeframe.
- B. Publish the plans on the project website and send an email requesting that all stakeholders review them.
- C. Set up meetings with each stakeholder to review the relevant sections of the plans and obtain approvals.
- D. Obtain stakeholder input and present the plans for approval at a single meeting.

**Answer: D ([LEAVE A REPLY](#))**

**NEW QUESTION: 49**

You are in the process of numerically analyzing the effects of identified risks. Which of the following are not tool/ techniques you can use in this process?

- A. Data gathering and representation techniques
- B. Probability-impact matrix
- C. Expert judgment
- D. Sensitivity analysis
- E. Probability distributions

**Answer: B ([LEAVE A REPLY](#))**

**NEW QUESTION: 50**

During project execution, a high-performing team member leaves. Following this loss, a planned quality audit is conducted that indicates the work products' quality standards are unmet.

What should the project manager do next?

- A. Perform a reserve analysis of the work performance data
- B. Create a cause-and-effect diagram
- C. Consult the resource management plan.
- D. Crash the schedule

**Answer: B ([LEAVE A REPLY](#))**

**NEW QUESTION: 51**

The basis of identification for current or potential problems to support later claims or new procurements is provided by:

- A. A risk urgency assessment.
- B. Procurement audits.
- C. Work performance information.
- D. The scope baseline.

**Answer: C ([LEAVE A REPLY](#))**

**NEW QUESTION: 52**

Work performance information is an input to Cost Control process. It includes all of the following EXCEPT:

- A. Percent complete of schedule activities
- B. Deliverables that have been completed versus not yet completed
- C. Cost authorized and incurred
- D. Estimates to complete schedule activities
- E. Calculate CV, SV, CPI, and SPI values for WBS components

**Answer: E ([LEAVE A REPLY](#))**

**NEW QUESTION: 53**

Cost Reimbursable contracts are equivalent to:

- A. Back charge contracts
- B. Fixed plus contracts
- C. Cost plus contracts
- D. Progress payment contracts
- E. None of the other alternatives apply .

**Answer:** ([SHOW ANSWER](#))

**NEW QUESTION: 54**

Which written document helps monitor who is responsible for resolving specific problems and concerns by a target date?

- A. Project Plan
- B. Responsibility Matrix
- C. Issue Log
- D. Scope Document

**Answer:** C ([LEAVE A REPLY](#))

Section: Monitoring and Controlling

**NEW QUESTION: 55**

An input to the Identify Stakeholders process is:

- A. The project management plan.
- B. The stakeholder register.
- C. Procurement documents.
- D. Stakeholder analysis.

**Answer:** C ([LEAVE A REPLY](#))

Section: Executing

Explanation

**NEW QUESTION: 56**

In a housing project, the real estate developer and the building contractor disagree about the quality of the work completed by the building contractor. The real estate developer has refused to pay for the work already completed and has also asked for a discount.

How should the project manager resolve the issue?

- A. Hire a third party to inspect of the work performed and determine the discounts that should be made.
- B. Propose an improvement to the housing project to compensate the real estate developer's expectations.
- C. Allow the real estate developer to calculate a discounted price as penalty for the alleged poor work quality.

**D.** Encourage both parties to use the alternative dispute resolution procedure as defined in the contract agreement.

**Answer: D** ([LEAVE A REPLY](#))

Section: Closing

#### **NEW QUESTION: 57**

A project manager for a computer life cycle replacement project has completed the project charter. However because there is no documentation of when the computers were deployed, the project manager develops a risk management plan?

What should the project manager do next?

- A.** Complete a sensitivity analysis to determine the impact.
- B.** Develop a risk breakdown structure (RBS) to categorize the risks
- C.** Add risk responses to the risk register
- D.** Identify the high-level risks associated with reviewing industry studies.

**Answer: D** ([LEAVE A REPLY](#))

#### **NEW QUESTION: 58**

An issue log is an input to which Project Human Resource Management process?

- A.** Manage Project Team
- B.** Acquire Project Team
- C.** Plan Human Resource Management
- D.** Develop Project Team

**Answer: (SHOW ANSWER)**

Section: Initiation

#### **NEW QUESTION: 59**

As the project manager, you have the option of proposing one of three systems to a client: a full-feature system that not only satisfies the minimum requirements but also offers numerous special functions (the

"Mercedes"); a system that meets the client's minimum requirements (the "Yugo"); and a system that satisfies the minimum requirements plus has a few extra features (the "Toyota"). The on-time records and associated profits and losses are depicted on the below decision tree. What is the expected monetary value of the "Toyota" system?

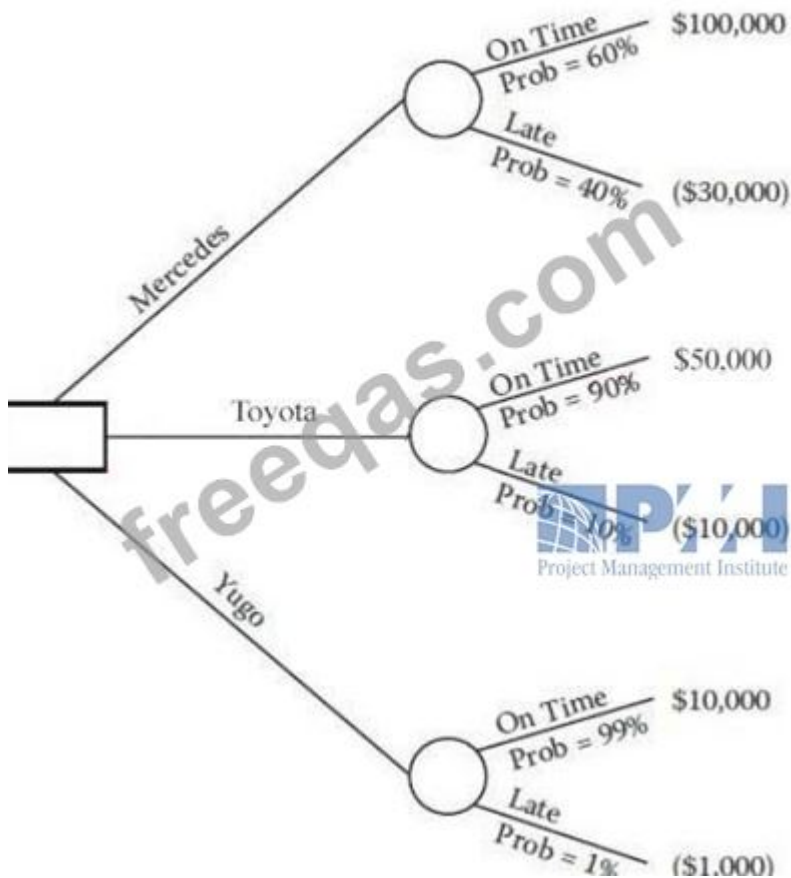

- A. \$9,900
- B. \$44,000
- C. \$45,000
- D. \$48,000

**Answer:** (SHOW ANSWER)

Explanation/Reference:

Explanation:

$$\begin{aligned}
 \text{EMV } V_{\text{Toyota}} &= (\$50,000 \times 90\%) + (\$10,000 \times 0\%) \\
 &= \$45,000 + (-\$1,000) \\
 &= \$44,000
 \end{aligned}$$

**NEW QUESTION: 60**

Change control procedures, configuration management knowledge base, versions, and baselines in the develop project management plan process are:

- A. Enterprise environmental factors
- B. Organizational process assets
- C. Part of the project's configuration management plan, which as a subsidiary plan will be part of the project management plan
- D. Part of the organization's management practices

**Answer:** B (LEAVE A REPLY)

Explanation/Reference:

Explanation:

Organizational process assets include formal and informal plans, policies, procedures, and guidelines. As an input to the develop project management plan process, they include the items listed as well as standardized guidelines, instructions, proposal evaluation criteria, and performance measurement criteria; project management plan template; change control procedures; project files from previous projects; and historical information and lessons learned.

**NEW QUESTION: 61**

Upon approval, a new project manager immediately begins a project. Three points into the project, the project manager identifies numerous obstacles. What should the project manager have done?

- A. Performed a quantitative risk analysis
- B. Planned risk responses
- C. Performed a qualitative risk analysis
- D. Identified risks

**Answer: (SHOW ANSWER)**

**Valid PMP Dumps** shared by PrepPdf.com for Helping Passing PMP Exam! PrepPdf.com now offer the **newest PMP exam dumps**, the PrepPdf.com PMP exam **questions have been updated** and **answers have been corrected** get the **newest** PrepPdf.com PMP dumps with Test Engine here: <https://www.preppdf.com/PMI/PMP-prepaway-exam-dumps.html> (2045 Q&As Dumps, **40%OFF Special Discount: Exam-Tests**)

**NEW QUESTION: 62**

What tool have project managers come to use to identify all of the costs associated with a project.

- A. A Gantt chart
- B. An arrow diagram network.
- C. A bill of materials
- D. A Gantt chart and an arrow diagram network.
- E. A work breakdown structure.

**Answer: (SHOW ANSWER)**

**NEW QUESTION: 63**

There are two major types of reserves used on projects. The \_\_\_\_\_ is for (usually major) scope changes that were not considered as part of the original plan, whereas the \_\_\_\_\_ is to compensate for minor changes in estimating, escalation factors.

- A. Management reserve, contingency.
- B. Contingency fund, management reserve.

- C. Unplanned allowance fund, budgetary reserve.
- D. Unplanned reserve, planned reserve.
- E. Management reserve, unplanned allowance fund.

**Answer: B (LEAVE A REPLY)**

**NEW QUESTION: 64**

A project to create a new product is completed and introduced into the market, our sales are much lower than expected. Analysis determines that the product is misaligned with the organization's core competencies.

During what activity should this have been discovered?

- A. Strategic performance evaluation
- B. Business case review
- C. Scope definition
- D. What-if scenario analysis

**Answer: B (LEAVE A REPLY)**

**NEW QUESTION: 65**

A project team has transitioned to full-time remote working. The project manager started noticing that some team members have not been completing their assigned tasks by the planned dates despite reminders during weekly team meetings. This has the potential for delaying the project delivery.

How should the project manager resolve this situation?

- A. Set up review sessions with each of the team members to identify the root cause of delays.
- B. Communicate the delivery dates twice a week to the team members to ensure timely delivery.
- C. Mentor the team members to work in a remote work environment to ensure productivity.
- D. Talk to the resource managers regarding the delay and request additional resources

**Answer: A (LEAVE A REPLY)**

**NEW QUESTION: 66**

Government regulations require that project deliverables be tested and approved by stakeholders before they can be accepted. However, these stakeholders are frequently too busy to perform the acceptance tests. Without these tests, project quality standards will be unmet, and the project cannot complete its deliverables.

What should the project manager do?

- A. Inform the project sponsors that the project is on hold and cannot be completed until these tests are completed
- B. Work with stakeholders to identify points in the work cycle where time can be designated to conduct the required tests
- C. Ask the quality assurance team to plan and execute the acceptance tests and present the results to the stakeholders

D. Work with the project team to plan and execute required acceptance tests on behalf of stakeholders

**Answer:** ([SHOW ANSWER](#))

**NEW QUESTION: 67**

Project information can be shared by team members and stakeholders through a variety of methods. Which of the following are NOT considered information retrieval systems?

- A. Electronic databases
- B. Manual filing systems
- C. Project management software
- D. Electronic mail
- E. Videoconferencing

**Answer:** D,E ([LEAVE A REPLY](#))

**NEW QUESTION: 68**

In an automobile company for which you are the project manager, the allowable standard deviation for a product required from the contractor is within 0.002 inches. However, while examining the product, you find out that the standard deviation is slightly more than 0.002 inches. You believe that the deviation is very small and hence, acceptable. In this case you must:

- A. Allow the lower standard this time but inform the contractor to be more quality conscious going forward
- B. Reject the product outright
- C. Document the lower quality level, ask the contractor for explanation and try to find a solution
- D. Allow the product because it is a very small deviation from the company standard which you think is acceptable.

**Answer:** ([SHOW ANSWER](#))

**NEW QUESTION: 69**

Your project team has created a new way to process claim forms. You want to know the percentage of claims that are now being paid within 10 days. To measure the number of claims that meet the 10-day goal vs. those that don't, which of these quality control techniques would you use?

- A. Variable sampling
- B. Attribute sampling
- C. Flowcharting
- D. Pareto diagrams

**Answer:** B ([LEAVE A REPLY](#))

In this situation you would track whether each case met the deadline or it didn't. However, in practice you may actually want to track the number of days it took to resolve each claim on a variable scale of 1 to 100 days, then look at how many were done in 10 days or less. In this case you would be using variable data

A. By the way, variable data and attribute data are plotted on different types of control charts. For the exam, be able to recognize...1) Data examples as either variable (range) or attribute (does or does not have the attribute.)2) The fact the sampling is part of the Quality Control process.

**NEW QUESTION: 70**

An organization uses a hybrid approach to project management. A project manager has been assigned to an external project, project A, where two of the three modules in the project require machine learning skills. The only machine learning expert in the project manager's organization is engaged in an internal project, project B, that is about to end.

What should the project manager do?

- A. Prioritize project A over project B since A is an external project and B is an internal project.
- B. Plan project A to start at the end of project B when the machine learning expert is available.
- C. Engage the human resource manager to employ a machine learning expert for project A.
- D. Plan project A in sprints, starting with the module that does not require machine learning skills.

**Answer: D (LEAVE A REPLY)**

**NEW QUESTION: 71**

Which group creativity technique asks a selected group of experts to answer questionnaires and provide feedback regarding the responses from each round of requirements gathering?

- A. Nominal group technique
- B. The Delphi technique
- C. Brainstorming
- D. Affinity diagram

**Answer: B (LEAVE A REPLY)**

**NEW QUESTION: 72**

Project or phase closure guidelines or requirements, historical information, and the lessons learned knowledge base are examples of which input to the Close Project or Phase process?

- A. Organizational process assets
- B. A work breakdown structure
- C. The project management plan
- D. Enterprise environmental factors

**Answer: (SHOW ANSWER)**

Section: Closing

Explanation/Reference:

**NEW QUESTION: 73**

A product is completed according to the project management plan, and team members are released to their functional areas. Upon receipt of the deliverables, a stakeholder realizes that the product cannot be accepted until a new set of requirements are included.

What should the project manager do next?

- A. Revise the stakeholder engagement plan
- B. Conduct the Perform Integrated Change Control process.
- C. Update the scope management plan
- D. Review the work breakdown structure (WBS) with the stakeholder.

**Answer: B ([LEAVE A REPLY](#))**

**NEW QUESTION: 74**

Which of the following is not a tool or technique for overall change control?

- A. Work Authorization system
- B. Project management information system
- C. Configuration management
- D. Performance measurement

**Answer: A ([LEAVE A REPLY](#))**

**NEW QUESTION: 75**

Which element does a project charter contain?

- A. Management reserves
- B. Work breakdown structure
- C. Stakeholder list
- D. Stakeholder register

**Answer: ([SHOW ANSWER](#))**

Section: Initiation

Explanation

**NEW QUESTION: 76**

Today, the primary cause of why projects are not completed on time and within cost and are terminated early is due to\_\_\_\_\_

- A. Contractual issues
- B. Complexity of the project
- C. An increase in the allocated time
- D. Behavioral-oriented reasons

**Answer: D ([LEAVE A REPLY](#))**

Explanation/Reference:

Explanation:

Behavioral reasons, rather than quantitative reasons, account for more project terminations because it is much more difficult to manage people than things. Issues such as poor morale, poor human relations, poor labor productivity, and no commitment from those involved in the project combine to thwart project success in many industries.

**Valid PMP Dumps** shared by PrepPdf.com for Helping Passing PMP Exam! PrepPdf.com now offer the **newest PMP exam dumps**, the PrepPdf.com PMP exam **questions have been updated** and **answers have been corrected** get the **newest** PrepPdf.com PMP dumps with Test Engine here: <https://www.preppdf.com/PMI/PMP-prepaway-exam-dumps.html> (2045 Q&As Dumps, **40%OFF Special Discount: Exam-Tests**)

**NEW QUESTION: 77**

After completing a project schedule, the project manager learns that the sponsor wants an earlier completion date without incurring additional costs. What technique can the project manager use to meet these requirements?

- A. Crashing
- B. Resource leveling
- C. Fast tracking
- D. Monte Carlo simulation

**Answer: C (LEAVE A REPLY)**

**NEW QUESTION: 78**

A Scrum team is analyzing the burndown chart on day four of a 15-day sprint. The burndown chart is shown below. What should the team do next?



- A. Continue with the sprint as the progress shows buffers for potential interruptions.
- B. Ask the product owner if some low-priority stories could be cut from the sprint.
- C. Ask the project team to select any additional stories as they have additional capacity than planned.
- D. Continue with the sprint work as planned and keep monitoring.

**Answer: B (LEAVE A REPLY)**

**NEW QUESTION: 79**

All of the following statements are true regarding the cost control process EXCEPT:

- A. Monitor cost performance and understand cost variances
- B. Inform stakeholders from authorize changes
- C. Changes are accurately reflected in the project scope
- D. Prevent authorize changes from being included in the cost baseline

**Answer: C ([LEAVE A REPLY](#))**

**NEW QUESTION: 80**

Which tool and technique identifies inefficient and ineffective policies, processes, and procedures?

- A. Scope reviews
- B. Scope audits
- C. Control chart
- D. Quality audits

**Answer: D ([LEAVE A REPLY](#))**

**NEW QUESTION: 81**

Which of the following organizational forms would be likely to have an individual with the title of Vice President for Project Management?

- A. None of the other alternatives apply
- B. Pure project
- C. Project coordinator
- D. Matrix
- E. Classical / traditional

**Answer: ([SHOW ANSWER](#))**

**NEW QUESTION: 82**

What does letter of agreement include?

- A. Meeting information and feedback
- B. Project description and signature
- C. Goal and budget
- D. Reports and communication plan

**Answer: ([SHOW ANSWER](#))**

As I understand it, Memorandum of Understanding (MOU) and Letter of Intent/Agreement (LOI/LOA) are all precontract agreement that will authorize the beginning of work before the actual contract is signed. I would think that a LOA should have the goal and the budget, indicating how much money is available to begin the work. So answer is C. The answer cannot be A or D, because that does not authorize the beginning of work. B or the actual project description and the signature should be part of the actual contract.

**NEW QUESTION: 83**

In preparing a good project definition, experienced project managers will:

- A. Try to convert objectives into quantifiable terms.
- B. Realize that only the "tip of the iceberg" may be showing. As a project manager, you must get beneath it.
- C. Concentrate mainly on the end product rather than costs or benefits. These come later.
- D. All of the other alternatives apply
- E. Understand that a project definition/plan is a dynamic rather than static tool, and thus subject to change.

**Answer: D ([LEAVE A REPLY](#))**

#### **NEW QUESTION: 84**

After preparing the final project report, the project manager realizes that the stakeholder distribution list is incomplete. What should the project manager do?

- A. Refer to the communications management plan
- B. Ask the project sponsors for a list of stakeholders
- C. Gather inputs from the team to develop the list of stakeholders.
- D. Refer to the stakeholder list created during the development of the project charter

**Answer: ([SHOW ANSWER](#))**

#### **NEW QUESTION: 85**

A particular process has two independent sources of variation. The standard deviation of the first source is 3 units and the standard deviation of the second source is 4 units. The standard deviation of the processes is:

- A. 3
- B. 4
- C. 5
- D. 7

**Answer: C ([LEAVE A REPLY](#))**

You have to take the Variance to calculate the SD. Variance = (S.D) \* (S.D) S.D = Sqrt of Variance  
 Variance of the first source = 3 \* 3 = 9  
 Variance of the second source = 4 \* 4 = 16  
 Total Variance = 25  
 S.D = Sqrt of variance = 5

#### **NEW QUESTION: 86**

Six sigma refers to the aim of setting tolerance limits at six standard deviations from the mean, whereas the normally expected deviation of a process is \_\_\_\_\_

- A. One standard deviation
- B. Two standard deviations
- C. Three standard deviations
- D. Undeterminable because of the unique nature of every process

**Answer: C ([LEAVE A REPLY](#))**

Explanation/Reference:

Explanation:

When the results of a sample of items measured falls within three standard deviations and that sample is representative of the entire population, you can assume that more than 99% of all items fall within that range. This generally accepted range of results has been used by quality control professionals through the years. Six sigma is a program started by Motorola that, from a statistical standpoint, indicates a quality standard of only 3.4 defects per million.

**NEW QUESTION: 87**

Which of the following statement about project phases and project life cycles is true?

- A. Similar Application Areas and Organizations have identical project life cycles.
- B. Project life cycle does not define the beginning and end of a project
- C. Project phases within a project life cycle are
- D. Subprojects may have distinct project life cycles

**Answer: D (LEAVE A REPLY)**

**NEW QUESTION: 88**

A contract management plan is a subsidiary of what other type of plan?

- A. Resource plan
- B. Project management plan
- C. Expected monetary value plan
- D. Cost control plan

**Answer: B (LEAVE A REPLY)**

**NEW QUESTION: 89**

You are project manager for a project. This project was originally scheduled for completion in 1 year but already 2 years over and now also project is in execution phase. Which statement is TRUE about the project?

- A. requirement added later therefore project is running late
- B. temporary project
- C. key resource has left the organization therefore running late
- D. limited license of development environment therefore running late

**Answer: B (LEAVE A REPLY)**

Project is continuing to expand means it is temporary project.

Other options can be achievable to complete the project if it is important for organization.

**NEW QUESTION: 90**

As the project manager, you are preparing your methods for quality management. You are looking for a method that can demonstrate the relationship between events and their resulting effects. You want to use a method to depict the events that cause a negative effect on quality. Which of the following is the BEST choice for accomplishing your objective?

- A. Control chart
- B. Ishikawa diagram
- C. Histogram
- D. Pareto chart

**Answer: B ([LEAVE A REPLY](#))**

**NEW QUESTION: 91**

A Work Breakdown Structure provides a framework from which all of the following can be done except:

- A. A network diagram, illustrating task dependencies, can be constructed
- B. Assignment of responsibility for each element can be made
- C. Task durations can be used in developing a working schedule for the project
- D. Performance can be tracked against the identified cost, schedule, and resource allocations

**Answer: A ([LEAVE A REPLY](#))**

**Valid PMP Dumps** shared by PrepPdf.com for Helping Passing PMP Exam! PrepPdf.com now offer the **newest PMP exam dumps**, the PrepPdf.com PMP exam **questions have been updated** and **answers have been corrected** get the **newest** PrepPdf.com PMP dumps with Test Engine here: <https://www.preppdf.com/PMI/PMP-prepaway-exam-dumps.html> (2045 Q&As Dumps, **40%OFF Special Discount: Exam-Tests**)

**NEW QUESTION: 92**

The project manager that allows and supports group discussions and decision making is called a(n) \_\_\_\_\_ manager.

- A. consultant autocratic
- B. shareholder
- C. None of the other alternatives apply .
- D. autocratic
- E. consensus

**Answer: E ([LEAVE A REPLY](#))**

**NEW QUESTION: 93**

Given the following estimates: Optimistic 3 days, Pessimistic 9 days, and most likely 6 days, what is the PERT weighted average?

- A. 4
- B. 6
- C. 6.1
- D. 6.3

**Answer: D ([LEAVE A REPLY](#))**

**NEW QUESTION: 94**

A project's purpose or justification, measurable project objectives and related success criteria, a summary milestone schedule, and a summary budget are all components of which document?

- A. Work breakdown structure
- B. Requirements document
- C. Project charter
- D. Project management plan

**Answer: (SHOW ANSWER)**

Section: Initiation

**NEW QUESTION: 95**

The CPI on your project is 0.84. This means that you should\_\_\_\_\_

- A. Place emphasis on improving the timeliness of the physical progress
- B. Reassess the life-cycle costs of your product, including the length of the life-cycle phase
- C. Recognize that your original estimates were fundamentally flawed, and your project is in an atypical situation
- D. Place emphasis on improving the productivity by which work was being performed

**Answer: D (LEAVE A REPLY)**

Section: Mix Questions

Explanation:

CPI = EV/AC and measures the efficiency of the physical progress accomplished compared to the baseline. A CPI of 0.84 means that for every dollar spent, you're only receiving 84 cents of progress.

Therefore, you should focus on improving the productivity by which work is being performed.

**NEW QUESTION: 96**

The Project Manager is involved in Project Scope Management. She will be involved for the entire project management life cycle. Which group of processes will she be involved in performing these activities?

- A. Initiation, Scope Planning, Scope Definition, Scope Verification, Scope Management
- B. Scope Forecasting, Scope Definition, Scope Verification, Scope Control
- C. Scope Planning, Scope Definition, Create WBS, Scope Verification, Scope Control
- D. Scope Planning, Scope Description, Scope Verification, Integrated Change Control

**Answer: (SHOW ANSWER)**

Section: Mix Questions

**NEW QUESTION: 97**

A plan has budgeted three weeks of effort for consultants, but the job was done in only two weeks. Calculate the variance:

- A. 33%

- B. None of the other alternatives apply .
- C. 1.50%
- D. 67%
- E. 75%

**Answer: A ([LEAVE A REPLY](#))**

**NEW QUESTION: 98**

Two sources of variation in the length of hex bolts exist. Production variation and measurement error. The QC manager knows that the standard deviation from these sources is 0.24" and 0.43" , respectively. What is the total standard deviation.

- A. .49 inch.
- B. .10 inch.
- C. .67 inch.
- D. .34 inch.
- E. .19 inch.

**Answer: ([SHOW ANSWER](#))**

**NEW QUESTION: 99**

The starting point in the development of a top-down PERT/CPM chart is the \_\_\_\_\_ .

- A. Work breakdown structure.
- B. Customer's milestone dates.
- C. Project specification tree.
- D. Listing of customer team meeting dates.
- E. Customer's deliverable list.

**Answer: A ([LEAVE A REPLY](#))**

**NEW QUESTION: 100**

A project manager has been asked to lead a project. The performing organization does not have a project management office (PMO) or formal governance policies procedures, and guidelines for this type of project What should the project manager do first to determine a governance approach for the project?

- A. Consult a subject matter expert (SME) as to the best governance policies, procedures, and guidelines to be used by the project
- B. Choose either a predictive or agile framework best suited to the nature of the project, and use this framework as the basis for project governance policies, procedures, and guidelines
- C. Consult with team members and stakeholders to determine whether the organization has any informal governance policies procedures, and guidelines
- D. Coach the self-managing team to produce tailored governance policies, procedures and guidelines for the project

**Answer: B ([LEAVE A REPLY](#))**

**NEW QUESTION: 101**

A vendor who historically has not had quality issues, is delivering low-quality parts. The project manager is concerned that this will cause a delay due to rework. What tool or technique should the project manager use to address this?

- A. Performance reporting
- B. Procurement control system
- C. Performance reviews
- D. Contract change control system

**Answer: B (LEAVE A REPLY)**

**NEW QUESTION: 102**

The CPI is .92, and the EV is US\$172,500. What is the actual cost of the project?

- A. US\$158,700
- B. US\$172,500
- C. US\$187,500
- D. US\$245,600

**Answer: C (LEAVE A REPLY)**

Section: Monitoring and Controlling

**NEW QUESTION: 103**

A project is on its sixth iteration out of seven. Select the two points where the team is performing better than expected. (Choose two.)



**Answer:**

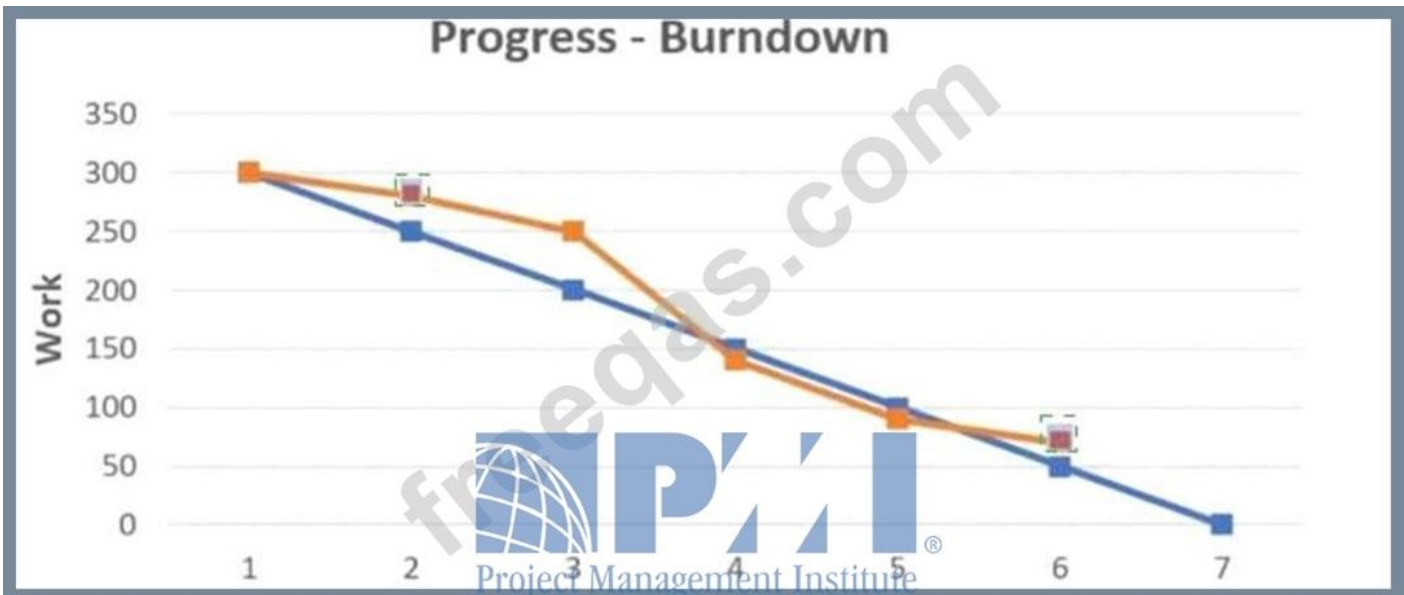

Explanation

Chart, line chart Description automatically generated



**NEW QUESTION: 104**

A media organization is working on starting a new channel. During the process, two team leads have different opinions about the branding of the channel. The head of the channel finds it challenging to work with the leads, and this dynamic starts to affect other team members. Since this issue may delay the channel's launch, what conflict management technique should the project manager use?

- A. Compromise/reconcile
- B. Smooth/accommodate
- C. Collaborate/problem solve
- D. Force/direct

**Answer: B (LEAVE A REPLY)**

Section: Initiation

**NEW QUESTION: 105**

Which of the following describes the Executing process group?

- A. Project plans are put into action.
- B. Project plans are developed.
- C. Project plans are published.
- D. Project performance measurements are taken and analyzed.

**Answer: A (LEAVE A REPLY)**

The Executing process group takes published project plans and turns them into actions to accomplish the goals of the project.

**NEW QUESTION: 106**

Two team members are arguing about which technology they should use when implementing iteration tasks.

The predictive approach was broken into several legations that need to be completed on time so as not to jeopardize the projects timely completion.

What should the project manager do to resolve this issue and help the team move on to the next iteration?

- A. Suggest their own approach to solve the issue and ask the team to follow it
- B. Allow the team to decide since the teams should be autonomous
- C. Call for an open dialogue which the team will arrive at through consensus
- D. Postpone the selection of the technology used until more information is gathered

**Answer: C (LEAVE A REPLY)**

**Valid PMP Dumps** shared by PrepPdf.com for Helping Passing PMP Exam! PrepPdf.com now offer the **newest PMP exam dumps**, the PrepPdf.com PMP exam **questions have been updated** and **answers have been corrected** get the **newest** PrepPdf.com PMP dumps with Test Engine here: <https://www.preppdf.com/PMI/PMP-prepaway-exam-dumps.html> (2045 Q&As Dumps, **40%OFF Special Discount: Exam-Tests**)

**NEW QUESTION: 107**

The budgeted cost of the work performed (BCWP) for a task that has just been completed can be calculated by:

- A. None of the other alternatives apply
- B. Multiplying the budgeted hours to complete the task by the budgeted labor rate.
- C. Multiplying the actual hours worked on the project by the budgeted labor rate.
- D. Cannot be determined.
- E. Dividing the actual hours required to complete the task by the budgeted labor rate.

**Answer: B (LEAVE A REPLY)**

**NEW QUESTION: 108**

A project manager for a government organization often deals with stakeholder engagement issues. Drag the interpersonal skill the project manager should use on the left to the correct situation on the right.

Interpersonal Skills	Situations
Decision making	Site workers often come up with complaints about working conditions, but the project manager cannot improve the conditions.
Negotiation	The project manager wants to stay updated on instability in the government and the possibility that the current government leader may resign.
Political awareness	The project manager is assigned to work in a rural area where people have different customs.
Cultural awareness	A new government has been formed, and the project manager has been awarded a chair position to reform government policies.

**Answer:**

Interpersonal Skills	Situations
Decision making	Negotiation
Negotiation	Political awareness
Political awareness	Cultural awareness
Cultural awareness	Decision making

**NEW QUESTION: 109**

An input to the Collect Requirements process is the:

- A. project management plan.
- B. project scope statement.

- C. requirements management plan.
- D. stakeholder register.

**Answer:** ([SHOW ANSWER](#))

**NEW QUESTION: 110**

ADM is an activity-on-arrow method. In this method, a dummy activity:

- A. Denotes any dependency relationship.
- B. Shows slack.
- C. Identifies customer team meeting dates.
- D. Identifies customer deliverables dates.
- E. Denotes a critical path relationship.

**Answer:** A ([LEAVE A REPLY](#))

**NEW QUESTION: 111**

A new project manager learns the work assigned to the team has already been decomposed to its lowest level. The project manager reviews the work and feels some additional useful information is missing. What should the project manager review?

- A. The WBS dictionary
- B. The requirements traceability matrix
- C. The business requirement documents (BRD)
- D. The project charter and scope statement

**Answer:** A ([LEAVE A REPLY](#))

**NEW QUESTION: 112**

A project manager is managing the scope of the project and creating a work breakdown structure (WBS) with the team members. How should the project manager organize the WBS?

- A. Team oriented
- B. Customer oriented
- C. Deliverable oriented
- D. Cost oriented

**Answer:** C ([LEAVE A REPLY](#))

**NEW QUESTION: 113**

Which process is not included in Project Time Management?

- A. Sequence Activities
- B. Work breakdown structure (WBS)
- C. Define Activities
- D. Develop Schedule and Control Schedule

**Answer:** B ([LEAVE A REPLY](#))

Work breakdown structure (WBS) is not included in Project Time Management but all other options provided in Project Time Management. 3/7/2009

**NEW QUESTION: 114**

A key stakeholder complains that protect information and details have not been received, and asks the project manager to immediately send them.

What should the project manager do first?

- A. Ask a team member to prepare and send the requested information
- B. Ask the project sponsor to send the requested information
- C. Review the stakeholder register
- D. Review the responsible, accountable consult, and inform (RACI) matrix

**Answer: ([SHOW ANSWER](#))**

**NEW QUESTION: 115**

A client asks a global IT company to develop a supply-chain monitoring system, a project manager then Deigns to assist in the creation of the project charter for the project sponsor. What should the project manager do next?

- A. Meet with key stakeholders and the sponsor to discuss project assumptions, success criteria, and critical inputs.
- B. Identify and define the most appropriate implementation approach for the project deliverables.
- C. Search the lessons learned repository for historical information on project charter development.
- D. Meet with the sponsor to outline a detailed timeline with project milestones for resource allocation purposes.

**Answer: ([SHOW ANSWER](#))**

**NEW QUESTION: 116**

The Project Manager is reviewing testing output. Generally, the data looks good. He does observe seven consecutive data points on one side of the mean in a couple of areas on the control chart.

What is this called?

- A. A violation of the Seven Run Rule
- B. Lucky seven gets eleven
- C. Acceptable measurements
- D. Too loose of specification limits

**Answer: ([SHOW ANSWER](#))**

Section: Mix Questions

**NEW QUESTION: 117**

Work performance information includes all the following EXCEPT \_\_\_\_\_

- A. Started deliverables
- B. Costs authorized and incurred
- C. Progress of deliverables

D. Completed deliverables

**Answer: B ([LEAVE A REPLY](#))**

Section: Mix Questions

Explanation:

Work performance information is an output of validate scope. It emphasizes deliverables whether or not they have started, their progress, and ones that have finished or have been accepted.

**NEW QUESTION: 118**

Which of the following is included in activity duration estimation?

- A. All of the above
- B. Information from previous experience
- C. Project team knowledge
- D. Commercial duration databases
- E. Time studies

**Answer: B,C,D ([LEAVE A REPLY](#))**

**NEW QUESTION: 119**

You have been promoted to Manager, Continuous Process Improvement. Your new position:

- A. Is a project because the work will be performed by people
- B. Is not a project because Continuous Process Improvement will continue indefinitely
- C. Is a project because improvements must be planned, executed, and controlled
- D. Is a project because it is constrained by limited resources

**Answer: B ([LEAVE A REPLY](#))**

**NEW QUESTION: 120**

Which of the following is not a technology factor that may affect the project communications plan:

- A. Immediacy of the need for the information
- B. Expected project staffing
- C. Length of the project
- D. Logistics of how many individuals will be involved with the project and at what locations

**Answer: D ([LEAVE A REPLY](#))**

**NEW QUESTION: 121**

At the first team meeting, the project manager uses the risks noted in the project charter as a starting point for developing the risk register. After identifying the risks, what should the project team do next?

- A. Perform quantitative risk analysis.
- B. Populate a probability and impact matrix.
- C. Calculate the management reserve.
- D. Develop contingent response strategies.

**Answer: ([SHOW ANSWER](#))**

**Valid PMP Dumps** shared by PrepPdf.com for Helping Passing PMP Exam! PrepPdf.com now offer the **newest PMP exam dumps**, the PrepPdf.com PMP exam **questions have been updated** and **answers have been corrected** get the **newest** PrepPdf.com PMP dumps with Test Engine here: <https://www.preppdf.com/PMI/PMP-prepaway-exam-dumps.html> (2045 Q&As Dumps, **40%OFF Special Discount: Exam-Tests**)

**NEW QUESTION: 122**

You are currently finishing a project under contract to develop and build some machining equipment for a customer. Your organization took over the obligation to solve certain problems if they come up during a contractual Warranty period of one year after Start of production. What do you not consider during the warranty period?

- A. Parts which were marked As "Is must be held available for free replacement in case of failure.
- B. At the end of the warranty period, the responsibility for the equipment will be turned over to the customer.
- C. Some team members must be held available during the warranty period in case that they have to solve problems.
- D. Incoming problems reported to the team must be handled immediately and with high priority.

**Answer: A (LEAVE A REPLY)**

**NEW QUESTION: 123**

Unplanned responses to emerging risks that were earlier accepted is also called a(an)

- A. Workaround
- B. Update to risk response plan
- C. Update to risk identification checklist
- D. Corrective Action

**Answer: A (LEAVE A REPLY)**

**NEW QUESTION: 124**

A project manager is assigned to an ongoing complex project. The team is delivering value each iteration However, the deliverables are internal and the customers are unaware of the deliverables.

Which action should the project manager take?

- A. Inform the customer about the progress and update them on the final deliverables
- B. Wait for an important milestone to complete and then inform the customer of the progress
- C. Ask the internal sales team to keep the customer informed of the delivered value
- D. Evaluate various delivery options in order to immediately demonstrate value to the customer

**Answer: (SHOW ANSWER)**

**NEW QUESTION: 125**

Which process involves aggregating the estimated costs of the individual schedule activities or work packages?

- A. Cost baseline
- B. Cost forecasting
- C. Cost variance
- D. Cost budgeting

**Answer: D (LEAVE A REPLY)**

Section: Monitoring and Controlling

**NEW QUESTION: 126**

Based on the following table, what is the total float for activity (B)?

Activity	Preceding	Duration/W
Start	None	0
A	Start	1
B	Start	2
C	Start	6
D	A	8
E	B,C	2
F	C	3
G	D	4
H	E	5
I	F	1
Finish	G,H,I	0

- A. 6 Weeks
- B. 0.0 Weeks
- C. 2 Weeks
- D. 4 Weeks

**Answer: D (LEAVE A REPLY)**

**NEW QUESTION: 127**

You've been assigned as a project manager on a research and development project for a new dental procedure. You're working in the Scope Planning process. What is the purpose of the project scope management plan?

- A. The project scope management plan describes and documents a scope baseline to help make future project decisions.
- B. The project scope management plan decomposes project deliverables into smaller units of work.
- C. The project scope management plan describes how project scope will be developed and how changes will be managed.

**D.** The project scope management plan describes how cost and time estimates will be developed for project scope changes.

**Answer:** ([SHOW ANSWER](#))

The scope management plan outlines how project scope will be managed and how changes will be incorporated into the project.

### **NEW QUESTION: 128**

Your company decided to award a contract for project management services on a pharmaceutical research project. Because your company is new to project management and does not understand the full scope of services that may be needed under the contract, it is most appropriate to award a \_\_\_\_\_

- A.** Firm-fixed-price contract
- B.** Fixed-price-incentive contract
- C.** Cost-plus-a-percentage-of-cost contract
- D.** Time-and-materials contract

**Answer:** **D** ([LEAVE A REPLY](#))

Section: Mix Questions

Explanation:

A time-and-materials contract is a type of contract that provides for the acquisition of supplies or services on the basis of direct labor hours, at specified fixed hourly rates for wages, overhead, general and administrative expenses, and profit; and materials at cost, including materials-handling costs.

### **NEW QUESTION: 129**

Decomposition is a technique used for both WBS development and activity definition. Which following statement best describes the role decomposition plays in activity definition as compared to creating the WBS?

- A.** Final output is described in terms of work packages in the WBS.
- B.** Final output is described as deliverables or tangible items.
- C.** Final output is described as schedule activities.
- D.** Decomposition is used the same way in scope definition and activity definition.

**Answer:** **C** ([LEAVE A REPLY](#))

Section: Mix Questions

Explanation:

Final output is described as schedule activities.

In the create WBS process, final output is described as deliverables or tangible items. In the define activities process, final output is described as activities.

### **NEW QUESTION: 130**

Reverse analysis is a tool/ technique in all of the following processes EXCEPT:

- A.** Risk monitoring and control

- B. Cost estimation
- C. Cost budgeting
- D. Activity resource estimation

**Answer:** ([SHOW ANSWER](#))

**NEW QUESTION: 131**

A new project manager is assigned to a project that will deliver a new and optimized credit system. The project manager is allowed to use a hybrid approach which is new to the organization to manage the project and new tools. In order to deliver the project successfully, what should the project manager focus on as part of the plan?

- A. Communicate with other project managers to see how they manage hybrid projects
- B. Develop a detailed schedule for the entire project in the planning phase and communicate that to the stakeholders
- C. Align with the organization's project management office (PMO) to inform and make them aware of the new approach
- D. Explain and communicate the new approach to the project sponsor and key stakeholders

**Answer:** D ([LEAVE A REPLY](#))

**NEW QUESTION: 132**

Design of experiments is an analytical technique which helps

- A. Determine how various statistical data will interrelate based on results
- B. Allow for random sampling
- C. Identify which variables have the most influence on the overall outcome
- D. Anticipate the probability that something will fail

**Answer:** ([SHOW ANSWER](#))

**NEW QUESTION: 133**

A project manager receives project charter approval for an expansion project. Subsequently, the government introduces a new regulation with which the expansion project must comply. This will significantly impact the project's schedule and budget. What should the project manager do?

- A. Estimate the impact of the new regulation, and establish a project plan that includes this impact
- B. Revise the project charter after estimating the impact of the new regulation, and then obtain approval
- C. Include the risk of the new regulation in the risk register, and monitor the impact of the risk.
- D. Start the project planning phase according to the approved project charter without considering the new regulation.

**Answer:** B ([LEAVE A REPLY](#))

**NEW QUESTION: 134**

An organization is awarded a large construction project. The project team is implementing an approach to continuously optimize execution efficiency.

What approach should the project team use as a basis for improvement?

- A. Total quality management (TQM)
- B. Plan-do-check-act (PDCA) cycle
- C. Six Sigma
- D. Lean Six Sigma

**Answer:** ([SHOW ANSWER](#))

Section: Executing

#### **NEW QUESTION: 135**

The LEAST effective form of communication for complex situations is:

- A. informal
- B. verbal - face to face and formal
- C. formal
- D. written
- E. verbal - face to face

**Answer:** B ([LEAVE A REPLY](#))

#### **NEW QUESTION: 136**

Which of the following methods is a project selection technique?

- A. Flowcharting
- B. Earned value
- C. Cost-benefit analysis
- D. Pareto analysis

**Answer:** C ([LEAVE A REPLY](#))

Section: Initiation

**Valid PMP Dumps** shared by PrepPdf.com for Helping Passing PMP Exam! PrepPdf.com now offer the **newest PMP exam dumps**, the PrepPdf.com PMP exam **questions have been updated** and **answers have been corrected** get the **newest** PrepPdf.com PMP dumps with Test Engine here: <https://www.preppdf.com/PMI/PMP-prepaway-exam-dumps.html> (2045 Q&As Dumps, **40%OFF Special Discount: Exam-Tests**)

#### **NEW QUESTION: 137**

You are in the process of controlling changes to the project scope. All of the following are tools/ techniques you can use EXCET:

- A. Replanning
- B. Change control system

- C. Variance analysis
- D. Configuration management system
- E. Inspection

**Answer: E ([LEAVE A REPLY](#))**

**NEW QUESTION: 138**

You are the project manager at Day-Old donuts a rapidly growing franchise selling premium donuts at a discount. Currently, your company is planning on opening additional stores throughout Europe. Your company is evaluating different areas for expansion including France, Germany and England. Your steering committee used a weighted score model and found that in England with a score of 75, provided the best opportunities for expansion. Which of the following statements are true?

- A. Weighted scoring models are constrained optimization method, and is tool/ technique of the initiation process group
- B. Weighted scoring models are benefit measurement method, and is tool/ technique of the initiation process group
- C. Weighted scoring models are benefit measurement method, and is input to the initiation process group
- D. Weighted scoring models are constrained optimization method, and is an input to the initiation process group

**Answer: B ([LEAVE A REPLY](#))**

**NEW QUESTION: 139**

Employee unions would most likely satisfy which level in Maslow's hierarchy of needs?

- A. Empowerment
- B. Self-actualization
- C. Belonging
- D. Safety
- E. Esteem

**Answer: C ([LEAVE A REPLY](#))**

**NEW QUESTION: 140**

A project manager is assigned to a global project where, during the planning process, team members from different regions are not agreeing to collaborate with each other. What should the project manager do?

- A. Coordinate a meeting with regional managers to ask for support
- B. Coordinate a meeting to understand the situation and resolve any conflicts.
- C. Review the organizational culture, structure, and governance
- D. Review lessons learned from previous projects that used the same team

**Answer: B ([LEAVE A REPLY](#))**

**NEW QUESTION: 141**

Recommended corrective actions are an input to which process?

- A. Direct and manage project execution
- B. Schedule development
- C. Integrate change control
- D. Scope control
- E. Scope verification

**Answer: C** ([LEAVE A REPLY](#))

**NEW QUESTION: 142**

As a project manager for a construction project, you understand the importance of closed contracts and correspondence for future references. Which of the following can be used to manage and store records, and correspondence?

- A. Performance reports
- B. Historical Information
- C. Lessons learned
- D. Project file

**Answer: B** ([LEAVE A REPLY](#))

**NEW QUESTION: 143**

Your management has prescribed that a quality audit be conducted at the end of every phase in a project.

This audit is part of the organization's \_\_\_\_\_

- A. Quality assurance process
- B. Quality control process
- C. Quality improvement program
- D. Process adjustment program

**Answer: A** ([LEAVE A REPLY](#))

Explanation/Reference:

Explanation:

Quality assurance is a managerial function that establishes processes or procedures in an organization or project to assist in determining whether quality standards and operational definitions are being met. It is the application of planned, systematic quality activities to ensure that the project will use all processes needed to meet requirements and is performed throughout the life of the project. Quality audits are a tool and technique to use.

**NEW QUESTION: 144**

Which task is most over budget?

- A. Task 2
- B. Task 3
- C. Task 1

D. Task 4

E. Task 5

**Answer: A ([LEAVE A REPLY](#))**

**NEW QUESTION: 145**

Conditions that are not under the control of the project team that influence, direct, or constrain a project are called:

A. Work performance reports

B. Context diagrams

C. Enterprise environmental factors

D. Organizational process assets

**Answer: ([SHOW ANSWER](#))**

**NEW QUESTION: 146**

A project manager and project team identify that the number of defects can be reduced by focusing on specific modules. They investigated and prioritized the area with the most defects and reduced them.

What did the project manager and team use?

A. Pareto diagram

B. Cause-and-effect diagram

C. Scatter diagram

D. Control chart

**Answer: ([SHOW ANSWER](#))**

**NEW QUESTION: 147**

Which of the following statements is true regarding schedule variances?

A. Schedule variances never impact the schedule.

B. Schedule variances sometimes impact the schedule.

C. Schedule variances impact scope, which impacts the schedule.

D. Schedule variances always impact the schedule.

**Answer: B ([LEAVE A REPLY](#))**

Schedule variances will sometimes-but not always-impact the schedule. Changes to noncritical path tasks will not likely impact the schedule, but changes to critical path tasks will always impact the schedule.

**NEW QUESTION: 148**

The process of identifying and documenting relationships among the project activities is known as:

A. Sequence Activities.

B. Control Schedule.

C. Define Activities.

D. Develop Schedule.

Answer: ([SHOW ANSWER](#))

**NEW QUESTION: 149**

At the first team meeting, the project manager uses the risks noted in the project charter as a starting point for developing the risk register. After identifying the risks, what should the project team do next?

- A. Perform quantitative risk analysis.
- B. Calculate the management reserve.
- C. Develop contingent response strategies.
- D. Populate a probability and impact matrix.

Answer: A ([LEAVE A REPLY](#))

**NEW QUESTION: 150**

One of the key benefits of the Plan Human Resource Management process is that it:

- A. outlines team selection guidelines and team member responsibilities.
- B. improves teamwork, interpersonal skills, and competencies.
- C. establishes project roles and responsibilities.
- D. provides an accurate appraisal of team member performance.

Answer: ([SHOW ANSWER](#))

**NEW QUESTION: 151**

A scenario is presented in which current variances are seen as typical. Here are the figures: PV=800, BAC=700, EV=675, AC=750.

- A. 778
- B. 780
- C. 861
- D. 833

Answer: ([SHOW ANSWER](#))

With the following

Explanation:

$EAC = [AC + (BAC - EV) / .9] = 861.11$  or 861 rounded down.[#1] In order to get this answer, you have to ADD the remaining budget (BAC - EV) to AC and THEN divide the sum by CPI. But that's contrary to what the parentheses indicate in PMBOK, that is:  $EAC = AC + ((BAC - EV)/CPI)$ . Now, if you were to obey the order of operation implied in PMBOK, you'd come up with 777.77 or 778 rounded up, which is answer A. So which one is it - 778 or 861?[#2] Actually, even though the formulas have a different meaning based on the context, mathematically they are the same:  $EAC = BAC / CPI$  with no variance  $EAC = AC + (BAC - EV) / CPI$  with variance, based on performance But,  $CPI = EV / AC$ , so  $EAC = AC + (BAC - EV) / CPI = AC + BAC / CPI - EV / CPI = AC + BAC / CPI - EV / (EV / AC) = AC + BAC / CPI - EV * (AC / EV) = AC + BAC / CPI - AC = BAC / CPI$

Why does this work? When there is no variance, the CPI should be 1, and the EAC should be the BAC.[#3] Forget about all that and just use  $BAC / CPI$  (see derivation below):  $700 / 0.9 = 778$ . You are right, the book is wrong.

**Valid PMP Dumps** shared by PrepPdf.com for Helping Passing PMP Exam! PrepPdf.com now offer the **newest PMP exam dumps**, the PrepPdf.com PMP exam **questions have been updated** and **answers have been corrected** get the **newest** PrepPdf.com PMP dumps with Test Engine here: <https://www.preppdf.com/PMI/PMP-prepaway-exam-dumps.html> (2045 Q&As Dumps, **40%OFF Special Discount: Exam-Tests**)

### NEW QUESTION: 152

You have been recently hired to be a project manager at a bio-tech company to develop treatment for diabetes. George is the vice president of R&D. he tell you that your project is over budget and that you need to reduce salary expenses by \$500K. Which type of power is George yielding in order to influence your decisions?

- A. Punishment power
- B. Legitimate power
- C. Expert power
- D. Referent power
- E. Coercive power

**Answer: B (LEAVE A REPLY)**

### NEW QUESTION: 153

The team has an approved charter and has started planning, determining potential risks that could occur on the project. Which of the following best describe project risk?

- A. It can be a negative event only
- B. It can be a positive event only
- C. It can be either a negative or positive event
- D. It can be something that has already happened

**Answer: (SHOW ANSWER)**

Section: Mix Questions

### NEW QUESTION: 154

When should quality planning be performed?

- A. While developing the project charter
- B. In parallel with the other planning processes
- C. As part of a detailed risk analysis
- D. As a separate step from the other planning processes

**Answer: B (LEAVE A REPLY)**

Section: Planning

**NEW QUESTION: 155**

Which of the following are false regarding corrective actions?

- A. Corrective actions generally do not require root cause analysis to identify the cause of variation
- B. Corrective actions are the outputs of process in the controlling process group
- C. Approved corrective are inputs to the direct and manage project execution process
- D. Corrective actions are used to bring expected future project performance in line with the project plan

**Answer: A ([LEAVE A REPLY](#))**

**NEW QUESTION: 156**

Which of the following is TRUE about most project life cycles?

- A. Staffing level is highest at the start.
- B. The stakeholders' influence is highest at the start.
- C. The level of uncertainty is lowest at the start.
- D. The cost of changes is highest at the start.

**Answer: B ([LEAVE A REPLY](#))**

Section: Initiation

**NEW QUESTION: 157**

Inputs to scope verification include the following

- A. Work results, product documentation, work breakdown structure, scope statement, and project performance measurement
- B. Work results, project documentation, work breakdown structure, scope statement, and project plan
- C. Work results, product documentation, work breakdown structure, scope change control, and project plan
- D. Work results, product documentation, work breakdown structure, scope statement, and project plan

**Answer: D ([LEAVE A REPLY](#))**

**NEW QUESTION: 158**

Who is responsible for initiating a project?

- A. Project management office (PMO)
- B. Program manager
- C. Project manager
- D. Project sponsor

**Answer: D ([LEAVE A REPLY](#))**

**NEW QUESTION: 159**

During a weekly progress meeting, a stakeholder announces that they are no longer able to cooperate with the project management team in obtaining the required government permits for construction. What should the project manager do first?

- A. Discuss the issue with the project sponsor.
- B. Update the issue log and inform other stakeholders.
- C. Exclude the activities that require the permits from the scope of work.
- D. Assume the responsibility of obtaining the permits.

**Answer: B (LEAVE A REPLY)**

Section: Monitoring and Controlling

Explanation/Reference:

**NEW QUESTION: 160**

Project A is being administered using a matrix form of organization. The project manager reports to a senior vice president who provides visible support to the project. In this scenario, which of the following statements best describes the relative power of the project manager?

- A. The project manager will probably not be challenged by project stakeholders.
- B. In this strong matrix, the balance of power is shifted to the functional line managers.
- C. In this tight matrix, the balance of power is shifted to the project manager.
- D. In this strong matrix, the balance of power is shifted to the project manager.

**Answer: (SHOW ANSWER)**

Section: Mix Questions

Explanation:

The project manager's ability to influence project decisions increases the higher up he or she \_\_\_\_\_ and the person to whom he or she reports \_\_\_\_\_ is placed in the organization. In the strong matrix, the project manager's authority ranges from moderate to high.

**NEW QUESTION: 161**

To improve the quality of project deliverables, the project manager decides to involve the project team in defining project standards, policies, and guidelines. The team thinks that this is a waste of effort, and would like to continue to execute the project as planned.

What should the project manager do next?

- A. Organize a project team meeting to create a shared vision.
- B. Produce the quality management plan, and distribute it to stakeholders.
- C. Meet with individual team members, and force them to comply.
- D. Log an issue with the team, and discuss it with the human resource department.

**Answer: A (LEAVE A REPLY)**

Section: Executing

Explanation

**NEW QUESTION: 162**

You are beginning a new project and a portion of the development will be created by a foreign company.

You are not sure how to do business with this company because it is offshore.

What document would be best to guide you in this business?

- A. Company's policies and procedures
- B. PMI Code of Conduct
- C. Local laws of the offshore company
- D. Historical information from past projects

**Answer: (SHOW ANSWER)**

Section: Mix Questions

### NEW QUESTION: 163

There are three projects:

Project A has an investment of \$ 3,000,000 and NPV of \$ 300,000 Project B has an investment of \$ 2,000,000 payback period of 2 years and NPV of \$ 200,000 Project C has an investment of \$ 1,000,000 payback period of 2 years and NPV of \$ 100,000. Which project should be selected if Net Present Value criteria is used for selection?

- A. Project B
- B. Project A
- C. Project A, B or C can be selected because all of them have equal value
- D. Project C

**Answer: B (LEAVE A REPLY)**

### NEW QUESTION: 164

You are in the process of painting your house. Since you do not want to start painting your house prior to rain storm, you check the weather report to make sure that weather is permitting. Which type of dependency best describes the relationship between the weather and your project?

- A. None of the choices are correct
- B. External dependency
- C. Mandatory dependency
- D. Discretionary dependency

**Answer: (SHOW ANSWER)**

### NEW QUESTION: 165

Which of the following is NOT a characteristic of message filtering?

- A. ethics
- B. reputation
- C. organizational status
- D. semantics
- E. media

**Answer: A (LEAVE A REPLY)**

**NEW QUESTION: 166**

The project manager notes that stakeholders are aware of the project and potential impacts and are actively engaged in ensuring that the project is a success. The engagement level of the stakeholders should be classified as:

- A. Supportive
- B. Leading
- C. Neutral
- D. Resistant

**Answer: B (LEAVE A REPLY)**

Section: Initiation

**Valid PMP Dumps** shared by PrepPdf.com for Helping Passing PMP Exam! PrepPdf.com now offer the **newest PMP exam dumps**, the PrepPdf.com PMP exam **questions have been updated** and **answers have been corrected** get the **newest** PrepPdf.com PMP dumps with Test Engine here: <https://www.preppdf.com/PMI/PMP-prepaway-exam-dumps.html> (2045 Q&As Dumps, **40%OFF Special Discount: Exam-Tests**)

**NEW QUESTION: 167**

The chances for successful completion of a multidisciplinary project are increased if project team members are-

- A. Focused on customer demands
- B. Problem oriented
- C. Politically sensitive to top management's needs
- D. Focused on individual project activities

**Answer: (SHOW ANSWER)**

**NEW QUESTION: 168**

A project manager is leading a virtual team that is geographically dispersed. What should the project manager do to avoid uncertainty in the project due to different cultures?

- A. Gather relevant cultural data and engage members in discussions covering their work ethics.
- B. Build a culturally neutral team that will not be affected by cultural differences.
- C. Start the project and add any uncertainty that arises to the risk register.
- D. Dissolve the virtual team and build a colocated team.

**Answer: A (LEAVE A REPLY)**

**NEW QUESTION: 169**

You are currently in the closing process and are involved in the product verification. Which of the following best describes the purpose of product verification?

- A. To verify whether the work was completed correctly
- B. To evaluate the work and compares the results to the project cost baseline
- C. To evaluate the work and compares the results to the project scope baseline
- D. To verify the goals of the project and verify whether the product meets requirements

**Answer:** ([SHOW ANSWER](#))

**NEW QUESTION: 170**

You are a project manager for Laredo Pioneer's Traveling Rodeo Show. You're heading up a project to promote a new line of souvenirs to be sold at the shows. You are getting ready to write the project management plan and know that all the following are true regarding the PMIS, except for one. Which of the following is true?

- A. The PMIS includes a change control system.
- B. The configuration management system is a subsystem of the PMIS.
- C. The PMIS is an automated system.
- D. The PMIS is a tool and technique of the Scope Planning process.

**Answer:** ([SHOW ANSWER](#))

The PMIS is a tool and technique of the Develop Project Management Plan process. It's one of the elements of the enterprise environmental factors, which is an input to the Scope Planning process.

**NEW QUESTION: 171**

During which process group is the quality policy determined?

- A. Planning
- B. Controlling
- C. Executing
- D. Initiating

**Answer:** ([SHOW ANSWER](#))

**NEW QUESTION: 172**

A project manager joins an ongoing firm fixed price (FFP) project. The project manager discovers that there is no lessons learned repository and that, to date, no retrospective meetings were held. The existing project budget does not cover lessons learned activities and, so far, this has not created any issues.

What should the project manager do?

- A. Proceed with the project plan, and record this risk in the risk register.
- B. Complete lessons learned activities using management reserve funds.
- C. Conduct the minimum amount of lessons learned activities in the team's spare time.
- D. Submit a change request to allocate a part of the budget for lessons learned activities.

**Answer:** D ([LEAVE A REPLY](#))

**NEW QUESTION: 173**

Your customer signed off on the requirements document and scope statement of your video game project last month. Today she stated she would like to make it an interactive game that can be played on a television and on a computer. This represents a requested scope change that, at a minimum \_\_\_\_\_

- A. Should be reviewed according to the perform integrated change control process
- B. Results in a change to all project baselines
- C. Requires adjustments to cost, time, quality, and other objectives
- D. Results in a lesson learned

**Answer: A (LEAVE A REPLY)**

Section: Mix Questions

Explanation:

A requested change is an output from the control scope process. Such a change should be handled according to the integrated change control process and may result in an update to the scope baseline or other components of the project management plan.

#### **NEW QUESTION: 174**

During a project's initiation phase a lessons learned sharing session was held with the team from another project. Low construction productivity was discussed as a potential delay to project completion. What should the project manager do next?

- A. Hire a construction management consultant to develop a comprehensive site execution plan
- B. Add construction productivity to the risk register and develop a mitigation strategy for site execution
- C. Discuss this issue with the project sponsor to request additional funding to implement mitigation
- D. Prequalify contractors with proven track records to eliminate productivity concerns

**Answer: A (LEAVE A REPLY)**

#### **NEW QUESTION: 175**

During a project, some products are acquired. The buyer and seller have agreed on a cost plus fixed fee (CPFF) contract. However, the project manager is concerned about the risks posed to the buyer associated with this type of contract.

Which contract type should have been used to lower risk for the buyer?

- A. Firm fixed price (FFP)
- B. Cost plus award fee (CPAF)
- C. Fixed price incentive fee (FPIF)
- D. Cost plus incentive fee (CPIF)

**Answer: A (LEAVE A REPLY)**

#### **NEW QUESTION: 176**

The project manager sent a draft project closure report to the project sponsor. The sponsor shared the document with a few stakeholders and received negative feedback on the deliverable's quality.

What should the project manager do?

- A. Revise the project closure report so that the decisions and actions causing the feedback are addressed.
- B. Ask the project team to respond to the stakeholders' feedback
- C. Ask the project sponsor to reset expectations with the stakeholders involved.
- D. Supplement the appropriate sections in the project closure report on outstanding risks.

**Answer: (**[SHOW ANSWER](#)**)**

### **NEW QUESTION: 177**

Assume your project communication management plan has been approved by your sponsor and the members of your Steering Committee. You are managing a global project and have team members working virtually in four continents and stakeholders in numerous locations. Your next step is to \_\_\_\_\_

- A. Set up an information management system
- B. Select communications technology
- C. Determine performance reporting methods
- D. Select a communications model

**Answer: B (**[LEAVE A REPLY](#)**)**

Section: Mix Questions

Explanation:

Although all four listed are tools and techniques in the manage communications process (another is communications methods), since this project is a virtual one, the choice of technology is an important consideration. It can vary from project to project and throughout the life cycle, but as the project manager the focus is to ensure the choice is important for the information that is communicated.

### **NEW QUESTION: 178**

Which of the following statements are true regarding the SPI (schedule performance index) measurement?

- A. A negative SPI indicates that schedule performance is better than expected
- B. A SPI less than one indicates that schedule performance is better than expected
- C. A positive SPI indicates that schedule performance is better than expected
- D. A SPI greater than one indicates that schedule performance is better than expected

**Answer: D (**[LEAVE A REPLY](#)**)**

### **NEW QUESTION: 179**

Which of the following is a schematic display of the project's schedule activities and the logical relationships among them?

- A. Project schedule network diagram
- B. Activity list
- C. Gantt chart
- D. Project milestone list

**Answer: A ([LEAVE A REPLY](#))**

**NEW QUESTION: 180**

Which of the following forecasts the most likely total project costs based on the current project performance to date?

- A. SV
- B. EAC
- C. CV
- D. EV
- E. VAC

**Answer: ([SHOW ANSWER](#))**

**NEW QUESTION: 181**

You are managing a complex construction project for your organization. As part of your Resource Management Plan, you are creating a bar chart illustrating the amount of time that a resource is scheduled to work over a period of time. This chart is also known as:

- A. Resource histogram
- B. Resource calendar
- C. Resource breakdown structure
- D. Control chart

**Answer: A ([LEAVE A REPLY](#))**

**Valid PMP Dumps** shared by PrepPdf.com for Helping Passing PMP Exam! PrepPdf.com now offer the **newest PMP exam dumps**, the PrepPdf.com PMP exam **questions have been updated** and **answers have been corrected** get the **newest** PrepPdf.com PMP dumps with Test Engine here: <https://www.preppdf.com/PMI/PMP-prepaway-exam-dumps.html> (2045 Q&As Dumps, **40%OFF Special Discount: Exam-Tests**)

**NEW QUESTION: 182**

There are some costs like legal costs or insurance costs are categorised as:

- A. Fixed costs
- B. Variable costs
- C. Direct costs
- D. Indirect costs

**Answer: D ([LEAVE A REPLY](#))**

Indirect costs: Costs that cannot be directly associated with the production of specific goods or services.

For example, legal costs, administration, and insurance costs.

**NEW QUESTION: 183**

How much time does the typical project manager spend communicating (formal and informal)?

- A. 75% - 90%
- B. 60% - 80%
- C. 40% - 60%
- D. 25% - 55 %
- E. 30% - 70%

**Answer: A ([LEAVE A REPLY](#))**

**NEW QUESTION: 184**

Which is generally not regarded as one of the three categories of culture that managers should master?

- A. Organizational culture
- B. National culture
- C. Project culture
- D. Functional culture

**Answer: ([SHOW ANSWER](#))**

**NEW QUESTION: 185**

Which activity involves ensuring that the composition of a projects configuration items is correct?

- A. Configuration Identification
- B. Configuration Status Accounting
- C. Configuration Verification and Audit
- D. Configuration Quality Assurance

**Answer: C ([LEAVE A REPLY](#))**

Section: Executing

**NEW QUESTION: 186**

A project manager has just completed a stakeholder engagement meeting where many points for discussion were deferred. The project manager must provide a response to the stakeholders at next month's meeting. What should the project manager do next?

- A. Document the deferred points in the issue log and assign them to responsible project team members
- B. Submit a change request for the deferred points to update the stakeholder engagement plan
- C. Update the risk register and prioritize the deferred points from the stakeholder engagement meeting

**D.** Revise the budget and schedule estimates to include the deferred points requested by the stakeholders

**Answer: A (LEAVE A REPLY)**

**NEW QUESTION: 187**

You are a contract project manager working with the State of Bliss. Your latest project involves rewriting the Department of Revenue's income tax system. One of the key stakeholders is a huge movie buff, and she has the power to promote you into a better position at the conclusion of this project. She has discovered that one of her favorite superstars lives in the State of Bliss and therefore must file income tax returns in that state. She asks you to look up the account of this movie star. What is the most appropriate response?

**A.** Report her to the management team.

**B.** Look up the information she has requested. Since the data is considered part of the project, there is no conflict of interest.

**C.** You believe that tax records are public information, so you comply with the request.

**D.** Refuse to comply with the request, citing conflict of interest and violation of confidential company data.

**Answer: D (LEAVE A REPLY)**

The situation presented here requires you to put the interest of the company and the confidentiality of the data above your own personal interests or those of your stakeholders. D is not the most correct response because it says you believe the information is public. This implies you haven't verified whether the data is private or public. Until you know, treat the data as confidential. In this case, the information is confidential and should be shared only with those who have a valid reason for using it.

Topic 7, Exam 7 (142 questions)

**NEW QUESTION: 188**

In the initial stage of the project life cycle, the project's technical objectives are apt to be understood only in a general sense. A major component of project conflict during this stage of the project is \_\_\_\_\_

**A.** Concerns over priorities and procedures

**B.** Concerns about technical issues

**C.** Schedules

**D.** Confusion of establishing a project in the matrix management environment

**Answer: D (LEAVE A REPLY)**

Explanation/Reference:

Explanation:

During project formation, there is always an element of confusion or lack of clarity regarding the balance of power between the project manager and functional managers. If not resolved, such confusion manifests itself in conflicts regarding technical decisions, resource allocation, and scheduling later in the project.

**NEW QUESTION: 189**

The "control points" in the work breakdown structure used for isolated assignments to work centers are referred to as:

- A. Code of accounts.
- B. Subtasks.
- C. Work packages.
- D. Integration points.
- E. Tasks.

**Answer:** ([SHOW ANSWER](#))

**NEW QUESTION: 190**

You work as a senior project manager for a leading manufacturer of tennis racquets. Management wants to explore new markets and new products to boost revenue and profits. You are leading a team to identify potential products. Because of your background in exercise science you have recommended developing a new type of tennis ball. But when you submitted the idea for review, executive management informed you that this product would not fit the organization's core competences. You need to go back to the drawing board and recommend other products using management's guidelines as:

- A. An Assumption
- B. A constraint
- C. A specification
- D. A technical requirement

**Answer:** ([SHOW ANSWER](#))

As far as this Question is concerned, a lot of us would opt for Choice B. However, my thoughts are as follows. Going by PMBOK's definition on Ch. 4 - Pg. 40, the restriction of having to work within the core competencies of the organization is not going to limit the performance of the project. Also, this restriction is going to apply to an input of the "Initiation" stage, i.e. the product description. So, it may be safe to treat this as an assumption.

If we treat this as an assumption, it is a factor that is valid for all planning purposes. It has an impact on the project. It may be that core competency gets progressively elaborated (detailed) during the course of the project.

**NEW QUESTION: 191**

Which of the following are NOT inputs to the Develop Project Charter process?

- A. Enterprise environmental Factors
- B. Project SOW
- C. Contract
- D. Organizational Process Assets
- E. Expert Judgment

**Answer:** E ([LEAVE A REPLY](#))

**NEW QUESTION: 192**

Your project involves the research and development of a new food additive. You're ready to release the product to your customer when you discover that a minor reaction might occur in people with certain conditions. The reactions to date have been very minor, and no known long-lasting side effects have been noted. As project manager, what should you do?

- A. Do nothing because the reactions are so minor that very few people will be affected.
- B. Inform the customer that you've discovered this condition and tell them you'll research it further to determine its impacts.
- C. Tell the customer you'll correct the reaction problems in the next batch, but you'll release the first batch of product to them now to begin using.
- D. Inform your customer that there is no problem with the additive except for an extremely small percentage of the population and release the product to them.

**Answer: B** ([LEAVE A REPLY](#))

Honesty and truthful reporting are required of PMPs. In this situation, you would inform the customer of everything you know regarding the problem and work to find alternative solutions.

**NEW QUESTION: 193**

You are developing a project charter and want to ensure that any changes that may occur after the project begins will be controlled rigorously. You have consulted your company's configuration management knowledge base, and it contains versions and baselines of all the following official company documents EXCEPT \_\_\_\_\_

- A. Standards
- B. Strategic plans
- C. Policies
- D. Procedures

**Answer: B** ([LEAVE A REPLY](#))

Explanation/Reference:

Explanation:

The configuration management knowledge base is an organizational process asset. It contains the versions and baselines of all company policies, practices, procedures, and standards, as well as pertinent project documents.

**NEW QUESTION: 194**

Which activity may occur at project or phase closure?

- A. Change requests
- B. Benchmarking
- C. Project management plan updates
- D. Acceptance of deliverables

**Answer: D** ([LEAVE A REPLY](#))

**NEW QUESTION: 195**

Some raw materials are required for a new factory project, most of which are procured from different countries. Based on their experience with similar projects, the project manager knows that the material from certain countries might be delayed by customs.

What should the project manager do?

- A. Implement a risk response.
- B. Perform a risk identification.
- C. Update the issue log.
- D. Conduct an impact analysis.

**Answer: D (LEAVE A REPLY)**

Section: Executing

**NEW QUESTION: 196**

The project is using a new server that cost \$25,000 US. The Project Manager is told to set up depreciation for the server over a five-year schedule, with the server having a value of \$0 at the end of five years.

Standard depreciation will be used in the calculation. What is the amount per year the server will depreciate?

- A. \$5,000 US
- B. \$10,000 US
- C. \$2,500 US
- D. Not enough information

**Answer: (SHOW ANSWER)**

**Valid PMP Dumps** shared by PrepPdf.com for Helping Passing PMP Exam! PrepPdf.com now offer the **newest PMP exam dumps**, the PrepPdf.com PMP exam **questions have been updated** and **answers have been corrected** get the **newest** PrepPdf.com PMP dumps with Test Engine here: <https://www.preppdf.com/PMI/PMP-prepaway-exam-dumps.html> (2045 Q&As Dumps, **40%OFF Special Discount: Exam-Tests**)

**NEW QUESTION: 197**

All of the following are inputs to the Close Project process EXCEPT:

- A. Administrative closure procedure
- B. Work performance information
- C. Deliverables
- D. Contract documentation
- E. Project management plan
- F. Enterprise environmental factors, organizational process assets

**Answer: A (LEAVE A REPLY)**

**NEW QUESTION: 198**

A project is nearing completion when the project manager learns that a change in market regulations may impact the project, what should the project manager do?

- A. Perform a cost-benefit analysis.
- B. Review the risk management plan.
- C. Update the cost baseline.
- D. Check the stakeholder register.

**Answer: B** ([LEAVE A REPLY](#))

**NEW QUESTION: 199**

A project manager develops a business case during project initiation. What areas should the project manager consider when developing the business case?

- A. Business benefits provided by project deliverables and the organizational strategy
- B. Business benefits provided by project deliverables and portfolio analysis
- C. Expected resource performance and the project's contribution to the strategic portfolio objectives
- D. Expected resource performance and cost-benefit analysis

**Answer: (**[SHOW ANSWER](#)**)**

**NEW QUESTION: 200**

Team building should be ongoing throughout the project life cycle. However, it is hard to maintain momentum and morale, especially on large, complex projects that span several years. One guideline to follow to promote team building is to \_\_\_\_\_

- A. Consider every meeting a team meeting, not the project manager's meeting
- B. Conduct team building at specific times during the project through off-site meetings
- C. Engage the services of a full-time facilitator before any team-building initiatives are conducted
- D. Develop the project schedule using the services of a project control officer and then issue it immediately to the team

**Answer: A** ([LEAVE A REPLY](#))

Explanation/Reference:

Explanation:

Team building should be made as important a part of every project activity as possible. Given that there are many meetings on projects, each team member should be made to feel that it is his or her meeting and not just the project manager's meeting. This will foster greater contribution by each team member.

**NEW QUESTION: 201**

Diagram:

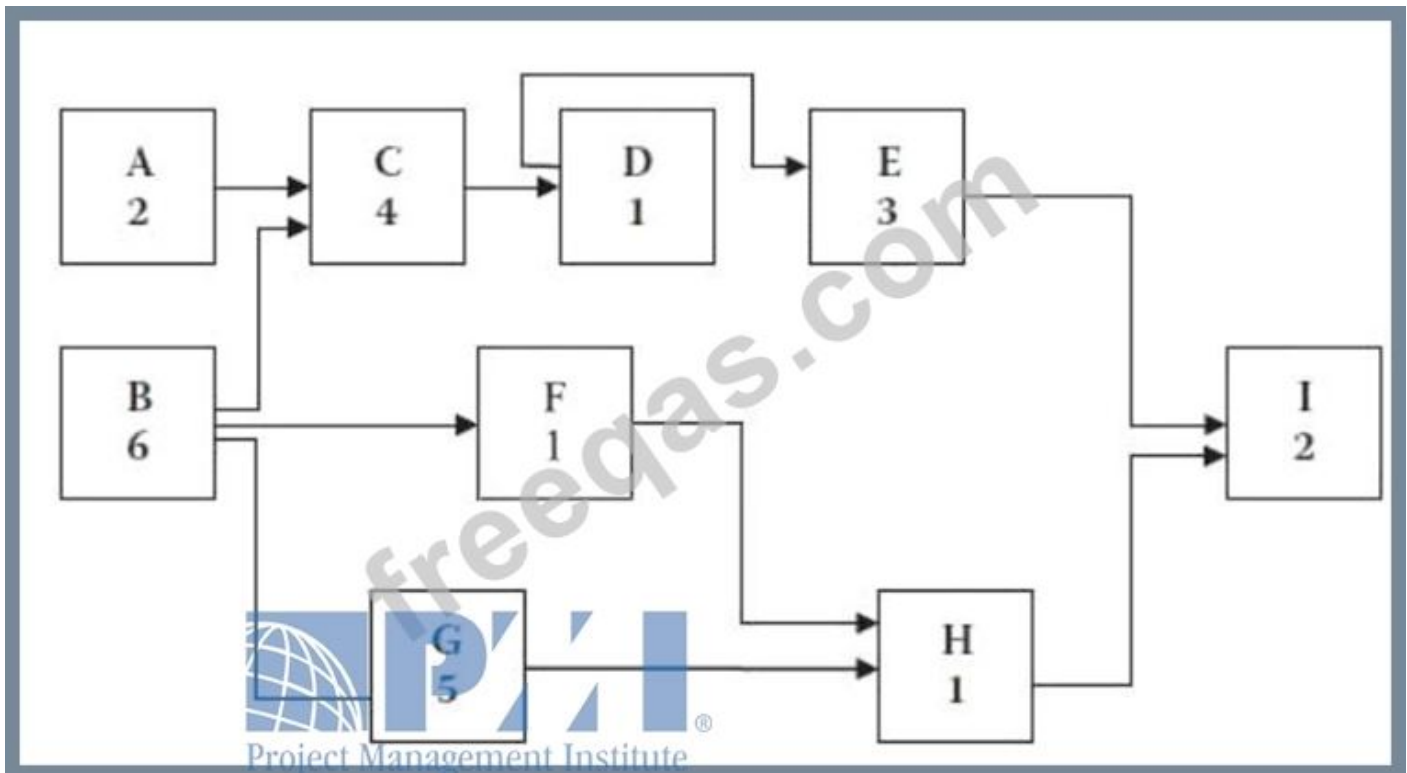

If a project planner imposes a finish time of 14 on the project with no change in the start date or activity durations, what is the total float of Activity E?

- A. -1
- B. 0
- C. 2
- D. Cannot be determined

**Answer: A (LEAVE A REPLY)**

Explanation/Reference:

Explanation:

The imposed finish date becomes the late finish for Activity I.

The late dates for each activity need to be recalculated. The dates for Activity E

become \_\_\_\_\_ ES = 10 EF = 13 LS = 9 LF = 12 Total float = LS - ES or 9 - 10 = (-1) or LS - EF or 12 - 13 = (-1)

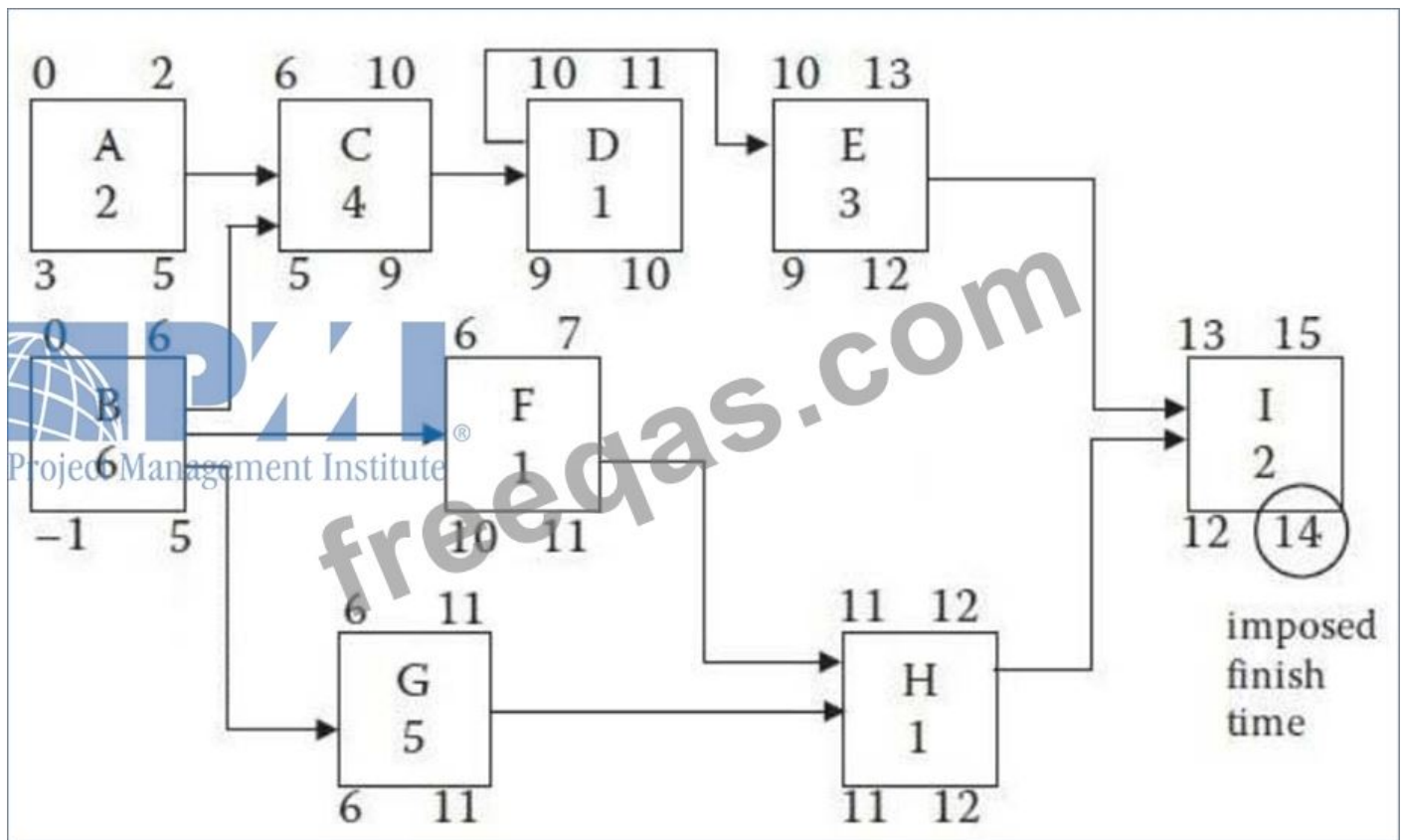

**NEW QUESTION: 202**

A company contracts a software vendor to implement and customize a new software application and assigns a project manager to initiate and lead the project. Which of the following inputs to the project charter describes the key deliverables?

- A. Business case
- B. Agreements
- C. Project scope statement
- D. Statement of work (SOW)

**Answer: C** ([LEAVE A REPLY](#))

Section: Initiation

**NEW QUESTION: 203**

Which of the following processes are part of the Project Integration Management Knowledge Area?

- A. Develop Project Management Plan, Collect Requirements, Create WBS
- B. Develop Project Management Plan, Control Scope, Develop Schedule
- C. Develop Project Charter, Define Scope, Estimate Costs
- D. Develop Project Charter, Direct and Manage Project Execution, Close Project or Phase

**Answer: (SHOW ANSWER)**

Section: Initiation

**NEW QUESTION: 204**

Reserve Analysis technique NOT used during \_\_\_\_\_.

- A. Control Costs
- B. Estimating Activity Duration
- C. Estimate Costs
- D. Determine Budget

**Answer: A (LEAVE A REPLY)**

Reserve analysis is used during Estimate Costs to calculate contingency buffers that apply to individual or group of activities. Reserve analysis is used during Determine Budget to calculate management contingency buffers that apply to the entire project. Reserve analysis is done during Activity Duration estimation in order to calculate duration buffers for individual or group of activities.

#### **NEW QUESTION: 205**

A project manager is creating a risk response plan. However, every time a risk response is suggested, another risk is identified that is caused by the response. Which of the following is the BEST thing for the project manager to do?

- A. Spend more time making sure the risk responses are clearly defined.
- B. Document the new risks and continue the Plan Risk Responses process.
- C. Make sure the project work is better understood.
- D. Get more people involved in the Identify Risks process since risks have been missed.

**Answer: B (LEAVE A REPLY)**

#### **NEW QUESTION: 206**

A project manager has just been informed that it is extremely important to complete the project on time.

Which activities should a project manager focus on to reduce the duration of the schedule without reducing the project scope?

- A. Activities with the lowest percent completion
- B. Activities with the lowest earned value
- C. Activities with the least cost impact
- D. Activities with the least float

**Answer: (SHOW ANSWER)**

#### **NEW QUESTION: 207**

A project manager assumes a three-year, multiphase project with tight timelines. Stakeholder schedules permit time for addressing only essential activities. How should the project manager handle updating the lessons learned?

- A. Schedule lessons learned meetings at the end of each phase.
- B. Wait to gather lessons learned until the end of each year.
- C. Periodically seek feedback on lessons learned.
- D. Fast track the project by gathering lessons learned only at the end of the project.

**Answer: A ([LEAVE A REPLY](#))**

Section: Executing

**NEW QUESTION: 208**

When does the project team determine which dependencies are discretionary?

- A. During the Define Activities process
- B. Before the Define Activities process
- C. Before the Sequence Activities process
- D. During the Sequence Activities process

**Answer: D ([LEAVE A REPLY](#))**

**NEW QUESTION: 209**

Clients are complaining about the delay on a product delivery timeline. It is confirmed that the issue is related to the product inventory and availability.

What should the project manager do to engage the stakeholders?

- A. Escalate the issue raised by the clients to the project sponsor,
- B. Work with the team and the product owner to define the next steps.
- C. Develop a solution with the team to identify the inventory level.
- D. Ask the team to work on the complaint raised by the clients.

**Answer: B ([LEAVE A REPLY](#))**

**NEW QUESTION: 210**

Who should always issue the project charter?

- A. A low-level manager of the performing organization
- B. A person internal to the project organization
- C. A high-level manager of the performing organization
- D. A project initiator or sponsor

**Answer: D ([LEAVE A REPLY](#))**

**NEW QUESTION: 211**

You joined the company recently as a Project Manager. To familiarize you with the company policies and best practices, you are teamed up with another project manager in the company through the "Buddy System." The communication between both of you will be:

- A. Horizontal
- B. Written
- C. Oral
- D. Formal

**Answer: A ([LEAVE A REPLY](#))**

**Valid PMP Dumps** shared by PrepPdf.com for Helping Passing PMP Exam! PrepPdf.com now offer the **newest PMP exam dumps**, the PrepPdf.com PMP exam **questions have been updated** and **answers have been corrected** get the **newest** PrepPdf.com PMP dumps with Test Engine here: <https://www.preppdf.com/PMI/PMP-prepaway-exam-dumps.html> (2045 Q&As Dumps, **40%OFF Special Discount: Exam-Tests**)

**NEW QUESTION: 212**

The network project has been very challenging. The cost performance index is presently 0.95 and the schedule performance index is 0.91. Risk could have been managed better from the start of this project. Halfway through the execution of the project management plan, the Project Manager assigned one person to do nothing but monitor for risks and work with the people who implemented the risk response plans. What would be a main goal to achieve from Risk Monitoring and Controlling?

- A. Qualitative analysis
- B. Corrective action
- C. Overall Risk ranking for the project
- D. Quantitative analysis

**Answer: B** ([LEAVE A REPLY](#))

Section: Mix Questions

**NEW QUESTION: 213**

Which of the following activities can be considered as part of risk mitigation

- A. Assessment of outcomes and assessment of probabilities
- B. assessment of outcomes
- C. risk identification
- D. purchasing insurance
- E. assessment of probabilities

**Answer: (**[SHOW ANSWER](#)**)**

**NEW QUESTION: 214**

This process is concerned with determining the engagement levels of the stakeholders, understanding their needs and interests, and understanding how they might impact the project or how the project may impact them:

- A. Manage Stakeholder Engagement
- B. Manage Communications
- C. Plan Stakeholder Engagement
- D. Control Communications

**Answer: C** ([LEAVE A REPLY](#))

**NEW QUESTION: 215**

All quality controls have passed, and a project deliverable is ready to be released to the customer. However, a change request to add new quality criteria has been approved. What should the project manager do first?

- A. Update the project management plan
- B. Update the risk register
- C. Use the new quality criteria for future deliverables
- D. Stop the release of the deliverable to the customer

**Answer: D ([LEAVE A REPLY](#))**

#### **NEW QUESTION: 216**

A team has different ideas on how to address a feature of a product under construction and; although the sprint began two days ago, they have still not reached a consensus. What should the project manager do?

- A. Offer an opinion about the pros and cons of each idea and try to reach a consensus in a facilitated meeting
- B. Propose ideas to the group, ask everyone to vote, and then choose the most popular idea
- C. Schedule a session to give everyone the chance to express their opinions about each idea, then vote and decide.
- D. Ask the product owner, who is the key stakeholder, to choose among the different ideas.

**Answer: C ([LEAVE A REPLY](#))**

#### **NEW QUESTION: 217**

Which project selection methods are used only in certain types of projects and are not going to be used for simpler projects?

- A. value measurement method
- B. benefit measurement method
- C. Constrained optimization models
- D. cost measurement method

**Answer: C ([LEAVE A REPLY](#))**

A second type of selection method is termed "constrained optimization models."

These types of models are in use only in certain types of projects and are not going to be used for simpler projects.

#### **NEW QUESTION: 218**

Which of the following is the amount of time that a scheduled activity may be delayed without delaying the early start of any immediately following schedule activities?

- A. Average float
- B. Total float
- C. Free float
- D. None of the choices are correct
- E. Critical float

**Answer: C ([LEAVE A REPLY](#))**

**NEW QUESTION: 219**

Which of the following can the project manager use to group stakeholders based on level of authority and level of concern?

- A. Power/interest grid
- B. Salience model
- C. Influence/impact grid
- D. Power/influence grid

**Answer: ([SHOW ANSWER](#))**

**NEW QUESTION: 220**

An organization is embarking on the deployment of a new digital solution that will revolutionize purchasing services. The project manager has created all the necessary plans and activities to ensure a successful integration and solution launch. There is a risk of a partner's system being unavailable which could impact the project negatively. What key activity is needed to ensure the project's success?

- A. Eliminate the risk by mandating the partner to change the system settings to facilitate an easier integration with the new solution
- B. Continuously monitor the risk of the partner system's unavailability, and put the proper resolution plans in place in case the risk materializes into an actual issue
- C. Mitigate the risk by developing alternative plans to make the solution ready and available without full integration capabilities
- D. Communicate to the project stakeholders that full integration may not be possible and that the project will potentially be delayed as a result.

**Answer: A ([LEAVE A REPLY](#))**

**NEW QUESTION: 221**

Please refer to the chart given below, which shows the time estimates for different tasks:

Task	Preceding Activity	Estimate Month
Start	-	0
1	Start	3
2	1	4
3	Start	2
5	3	5
4	Start	7
5	4	7
End	2	3
End	5	4

What is the impact on the project if task 1->2 takes 2 months more than what was earlier planned? (Choose best answer)

- A. The project float will increase by 2 months
- B. The duration of the project will increase by 1 month
- C. The duration of the project will increase by 2 months
- D. The risk in the project will increase

**Answer: D (LEAVE A REPLY)**

**NEW QUESTION: 222**

Typically, the seller receives formal written notice that the contract has been completed by the \_\_\_\_\_

- A. Project manager

- B. Authorized procurement administrator
- C. Member of the project management team responsible for daily contract administration
- D. Purchasing department head

**Answer: B ([LEAVE A REPLY](#))**

Explanation/Reference:

Explanation:

The buyer, through its authorized procurement administrator, is responsible for providing the seller with formal written notice of contract completion. The procurement administrator does so when the seller has met all contractual requirements as articulated in the contract. PMI®,

### **NEW QUESTION: 223**

A manufacturing plant project is ready for hand-over to the maintenance manager. The maintenance manager advises that the new plant is noncompliant with the company's maintenance standards.

What should the project manager have done to avoid this?

- A. Generated a change request
- B. Conducted a stakeholder analysis
- C. Used expert judgment
- D. Updated the communications management plan

**Answer: ([SHOW ANSWER](#))**

### **NEW QUESTION: 224**

The Contract management plan differs from the Procurement management plan by which characteristics?

- A. The contract management plan is written by the project manager, the procurement management plan is written by the procurement department.
- B. The contract management plan is output of the Plan contracting and acquisition process, the procurement management plan is output of the Select sellers process.
- C. The contract management plan describes the type of contracts to be used. The procurement management plan describes how the contract will be managed.
- D. The procurement management plan relates to the project, while a contract management plan may be written for each individual procurement item.

**Answer: ([SHOW ANSWER](#))**

### **NEW QUESTION: 225**

Please refer to the chart given below:

Task	Preceding Activity	Estimate
Start	-	0
1	Start	3
2	1	4
3	Start	2
5	3	5
4	Start	7
5	4	7
End	2	3
End	5	4

What is the length of the critical path?

- A. 12
- B. 11
- C. 10
- D. 14

Answer: A ([LEAVE A REPLY](#))

#### NEW QUESTION: 226

Identifying major deliverables, deciding if adequate cost estimates can be developed, and identifying tangible components of each deliverable are all part of which of the following?

- A. Resource breakdown structure
- B. Work breakdown structure

- C. Organizational breakdown structure
- D. Bill of materials

**Answer:** ([SHOW ANSWER](#))

**Valid PMP Dumps** shared by PrepPdf.com for Helping Passing PMP Exam! PrepPdf.com now offer the **newest PMP exam dumps**, the PrepPdf.com PMP exam **questions have been updated** and **answers have been corrected** get the **newest** PrepPdf.com PMP dumps with Test Engine here: <https://www.preppdf.com/PMI/PMP-prepaway-exam-dumps.html> (2045 Q&As Dumps, **40%OFF Special Discount: Exam-Tests**)

**NEW QUESTION: 227**

A project manager providing information to the right audience, in the right format, at the right time is an example of which type of communication?

- A. Efficient
- B. Effective
- C. Push
- D. Pull

**Answer: B** ([LEAVE A REPLY](#))

Section: Executing

**NEW QUESTION: 228**

Qualitative risk analysis requires accurate data as its input. Risk data quality assessment ranking is a technique to evaluate the degree to which the data regarding risks would be careful. Risk quality data assessment involves examining all of the following EXCEPT:

- A. Extent of understanding of risk
- B. Reliability and integrity of data
- C. Probability of the risks
- D. Data available about the risk
- E. Quality of eh data

**Answer: C** ([LEAVE A REPLY](#))

**NEW QUESTION: 229**

Which document defines how a project is executed, monitored and controlled, and closed?

- A. Strategic plan
- B. Project charter
- C. Project management plan
- D. Service level agreement

**Answer: C** ([LEAVE A REPLY](#))

Section: Planning

**NEW QUESTION: 230**

Which of the following makes up the project scope baseline?

- A. The WBS, project scope statement, and WBS dictionary
- B. The project scope statement
- C. The scope management plan and WBS
- D. The scope management plan, the WBS, and the WBS dictionary

**Answer:** ([SHOW ANSWER](#))

The scope baseline consists of the project scope statement, the WBS, and the WBS dictionary.

**NEW QUESTION: 231**

Overlooking negative stakeholders can result in a/an:

- A. decreased likelihood of the projects progress being impeded.
- B. decreased likelihood of conflicting interests between stakeholders.
- C. increased likelihood of project failure.
- D. increased likelihood of project success.

**Answer:** C ([LEAVE A REPLY](#))

**NEW QUESTION: 232**

Graphical displays of accumulated cost and labor hours, plotted as a function of time, are called:

- A. Variance reports
- B. Trend analysis
- C. Baseline control
- D. S curves
- E. Earned value reporting

**Answer:** D ([LEAVE A REPLY](#))

**NEW QUESTION: 233**

After a couple of iterations the project manager decides to present the product to a key stakeholder. The stakeholder's feedback is that the team missed the mark on many features. What should the project manager do to avoid this in the future?

- A. Incorporate design thinking practices into the project life cycle to better understand the product's personas and be more effective to match their needs.
- B. Set up requirements-gathering sessions with all key stakeholders to evaluate the scope once again and reprioritize the backlog based on the sessions.
- C. Schedule adequate sprint demos to gather early feedback from the stakeholders and adapt the plan accordingly.
- D. Evaluate the team's skills to look for someone with experience in product design and assign that person the task of rebuilding the product interface.

**Answer:** ([SHOW ANSWER](#))

**NEW QUESTION: 234**

The primary benefit of the Plan Schedule Management process is that it:

- A. provides guidance to identify time or schedule challenges within the project.
- B. tightly links processes to create a seamless project schedule.
- C. creates an overview of all activities broken down into manageable subsections.
- D. guides how the project schedule will be managed throughout the project.

**Answer: D** ([LEAVE A REPLY](#))

**NEW QUESTION: 235**

A project manager, working on a project with members in different locations, spends a significant amount of time explaining to the team that the lack ownership of their work and that project performance is deteriorating. Some team member are frustrated and want to resign, as they feel overloaded.

What should the project manager do first to control this situation?

- A. Conduct regular team meeting to ensure that team member are updated on overall project performance.
- B. Develop a recognition and rewards plan to motivate the team to do their work
- C. Provide training to the team members to improve their performance
- D. Share the team roles and responsibilities, and obtain consensus from each individual on the team.

**Answer: A** ([LEAVE A REPLY](#))

**NEW QUESTION: 236**

Control accounts\_\_\_\_\_

- A. Are charge accounts for personnel time management
- B. Summarize project costs at level 2 of the WBS
- C. Identify and track management reserves
- D. Represent the basic level at which project performance is measured and reported

**Answer: (SHOW ANSWER)**

Section: Mix Questions

Explanation:

Control accounts represent a management control point where scope, budget (resource plans), actual costs, and schedule are integrated and compared to earned value for performance measurement.

**NEW QUESTION: 237**

Which of the following processes audits the quality requirements and the results from quality control measures to ensure appropriate quality standards and operational definitions are used?

- A. Perform Quality Control
- B. Quality Metrics
- C. Perform Quality Assurance

D. Plan Quality

Answer: C ([LEAVE A REPLY](#))

Section: Monitoring and Controlling

**NEW QUESTION: 238**

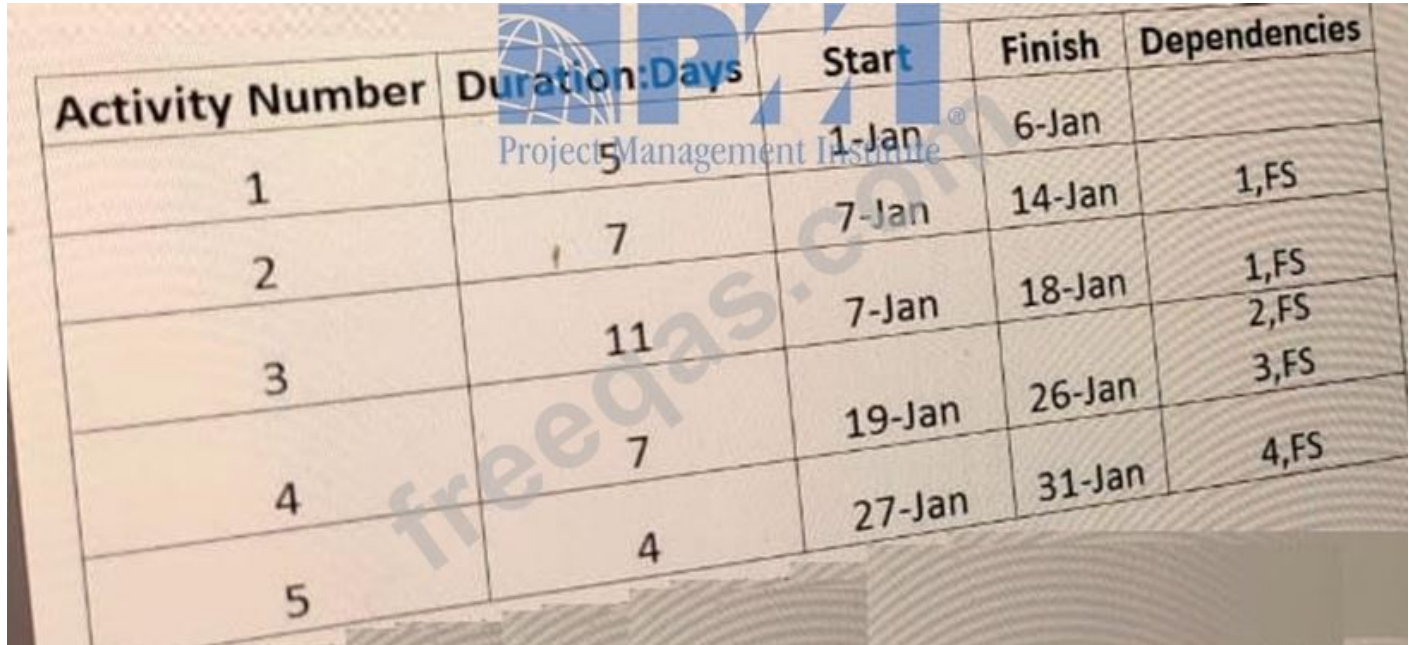

Activity Number	Duration:Days	Start	Finish	Dependencies
1	5	1-Jan	6-Jan	
2	7	7-Jan	14-Jan	1,FS
3	11	7-Jan	18-Jan	1,FS 2,FS
4	7	19-Jan	26-Jan	3,FS
5	4	27-Jan	31-Jan	4,FS

Based on the project scheduled, how much float is there for activity number 4?

A. 4 days

B. 0 days

Answer: A ([LEAVE A REPLY](#))

**NEW QUESTION: 239**

The sending or conveying of information from one place to another is the process of

A. Networking

B. Interacting

C. Promoting

D. Interfacing

E. Transmitting

Answer: E ([LEAVE A REPLY](#))

**NEW QUESTION: 240**

A set of high-impact repetitive tasks must be executed during a project. What can the project manager use to ensure that all team members.

Consistently perform these tasks in the same manner?

A. Quality audits

B. Quality metrics

C. Quality checklists

D. Quality control

Answer: ([SHOW ANSWER](#))

**NEW QUESTION: 241**

Which of the following factors is lowest at the start of the project?

- A. Stakeholder influences
- B. Risk
- C. Uncertainty
- D. Cost of changes

Answer: ([SHOW ANSWER](#))

**Valid PMP Dumps** shared by PrepPdf.com for Helping Passing PMP Exam! PrepPdf.com now offer the **newest PMP exam dumps**, the PrepPdf.com PMP exam **questions have been updated** and **answers have been corrected** get the **newest** PrepPdf.com PMP dumps with Test Engine here: <https://www.preppdf.com/PMI/PMP-prepaway-exam-dumps.html> (2045 Q&As Dumps, **40%OFF Special Discount: Exam-Tests**)

**NEW QUESTION: 242**

A no-cost settlement sometimes is used \_\_\_\_\_

- A. To close out a successful contract
- B. In lieu of formal termination procedures
- C. When buyer property has been furnished under the contract
- D. When such an arrangement is acceptable to one of the parties involved

Answer: **B** ([LEAVE A REPLY](#))

Explanation/Reference:

Explanation:

A no-cost settlement can be used in lieu of formal termination procedures when the seller has indicated that such an arrangement is acceptable, no buyer property has been furnished under the contract, no payments are due the seller, no other obligations are outstanding, and the product or service can be readily obtained elsewhere.

**NEW QUESTION: 243**

Which statement is true about the project management body of knowledge?

- A. Recognized by every project manager
- B. Constantly evolving
- C. The sum of all knowledge related to project management
- D. A sum of knowledge that should be applied on every project

Answer: ([SHOW ANSWER](#))

Section: Initiation

**NEW QUESTION: 244**

Which of the following is an example of recommended corrective action in risk management?

- A. Conducting a risk audit
- B. Engaging in additional risk response planning
- C. Performing the contingency plan
- D. Conducting a risk review

**Answer: C (LEAVE A REPLY)**

Explanation/Reference:

Explanation:

Corrective action in risk management is the process of making changes to bring expected performance in line with the risk management plan. Such action consists of performing either the planned risk response, such as implementing contingency plans, or a workaround.

**NEW QUESTION: 245**

A project manager is leading a regulatory project that involves multiple geographic locations and has a strict deadline. Although the company has no previous experience with this type of project the stakeholders have approved it.

What tool or technique should the project manager use to address the lack of expertise?

- A. Market research
- B. Focus groups
- C. Benchmarking
- D. Brainstorming

**Answer: D (LEAVE A REPLY)**

**NEW QUESTION: 246**

The primary advantage of using decision-tree analysis in project risk management is that it \_\_\_\_\_

- A. Considers the attitude of the decision maker toward risk
- B. Forces consideration of the probability of each outcome
- C. Helps to identify and postulate risk scenarios for the project
- D. Shows how risks can occur in combination

**Answer: B (LEAVE A REPLY)**

Explanation/Reference:

Explanation:

As a graphical way to bring together information, decision-tree analysis quantifies the likelihood of failure and places a value on each decision. Usually applied to cost and time considerations, this form of risk analysis may be linked to a sensitivity analysis.

**NEW QUESTION: 247**

A project manager is assigned to a new project. Many of the project deliverables need to be outsourced.

What should the project manager use to document the project deliverables?

- A. Memorandum of understanding (MOU)
- B. Scope management plan
- C. Statement of work (SOW)
- D. Service level agreement (SLA)

**Answer: C ([LEAVE A REPLY](#))**

#### **NEW QUESTION: 248**

A retail expansion project is going relatively well, but the people doing work on the project are complaining that it seems as though they answer to two bosses on the project, each with conflicting agendas. This is an example of what type of project environment?

- A. Functional
- B. Matrix
- C. Tight matrix
- D. Projectized

**Answer: ([SHOW ANSWER](#))**

Section: Mix Questions

#### **NEW QUESTION: 249**

A project manager is instructed by the project sponsor to draft the project charter. The project sponsor asks the project manager to involve a particular stakeholder in order to provide necessary resources. However, the stakeholder is refusing to get involved because the stakeholder thinks that there is no benefit in using the project deliverable. What should the project manager do to resolve this?

- A. Escalate to the project sponsor due to the political nature of the issue
- B. Consider the stakeholder as a risk and evaluate possible solutions with the project team
- C. Improve communication with the stakeholder to obtain their assistance in the future
- D. Meet with the stakeholder to discuss the impact of the deliverable

**Answer: A ([LEAVE A REPLY](#))**

#### **NEW QUESTION: 250**

A technical lead has complained to the project manager about a team member's performance. The team member has repeatedly missed tasks that have put sprint commitments at risk. What should the project manager do?

- A. Remove the team member from the team and hire a more skilled one
- B. Ask the technical lead to discuss performance directly with the team member
- C. Meet with the team member to understand the situation and provide feedback.
- D. Ask the technical lead to provide more training to the team member

**Answer: C ([LEAVE A REPLY](#))**

#### **NEW QUESTION: 251**

Good project objectives must be:

- A. Overly complex
- B. Established without considering resource bounds
- C. Measurable, intangible and verifiable
- D. General rather than specific
- E. Realistic and attainable

**Answer: E (LEAVE A REPLY)**

**NEW QUESTION: 252**

Who is the stakeholder of the project?

- A. Functional Manager
- B. CEO of the company.
- C. User who is going to use the product.
- D. VP of sales division

**Answer: C (LEAVE A REPLY)**

A user of the project's product is always a stakeholder, while the others may or may not be stakeholder.

**NEW QUESTION: 253**

Using the PMBOK definition of contingency reserve, which of the following statements about contingency reserves is false?

- A. Contingency reserves may be set aside for known unknowns.
- B. Contingency reserves are normally included in the project's cost and schedule baselines.
- C. A contingency reserve is a separately planned quantity used to allow for future situations which may be planned for only in part.
- D. Contingency reserves may be set aside for unknown unknowns.

**Answer: D (LEAVE A REPLY)**

**NEW QUESTION: 254**

A project manager's virtual team is midway through a sprint with complex tasks that are behind schedule. During a daily stand-up meeting a new member of the team interrupts and asks everyone to define their position and what they were working on before this current sprint. What should the project manager do?

- A. Address the situation immediately by answering the new member's question
- B. Ask each team member to explain their role and the nuances of their day-to-day activities
- C. Ask the team to give their attention to the new team member and answer any questions for clarification
- D. Respectfully inform the team member that this would be best handled in another meeting

**Answer: D (LEAVE A REPLY)**

**NEW QUESTION: 255**

A local supplier is unable to meet a delivery date. The project team did not anticipate this new threat to the supply of the product. Importing this product will cost the project twice the price that the local vendor charges.

What should the project manager use to fund this effort?

- A. Contingency reserve
- B. Project budget reserve
- C. Management reserve
- D. Risk response reserve

**Answer: C (LEAVE A REPLY)**

Section: Executing

### NEW QUESTION: 256

Which of the following includes how requirements activities will be planned, tracked, and reported?

- A. Configuration management plan
- B. Schedule baseline
- C. Requirements management plan
- D. Scope baseline

**Answer: C (LEAVE A REPLY)**

**Valid PMP Dumps** shared by PrepPdf.com for Helping Passing PMP Exam! PrepPdf.com now offer the **newest PMP exam dumps**, the PrepPdf.com PMP exam **questions have been updated** and **answers have been corrected** get the **newest** PrepPdf.com PMP dumps with Test Engine here: <https://www.preppdf.com/PMI/PMP-prepaway-exam-dumps.html> (2045 Q&As Dumps, **40%OFF Special Discount: Exam-Tests**)

### NEW QUESTION: 257

You are in the process of controlling changes to the project scope. All of the following are outputs of this process EXCEPT:

- A. Requested changes
- B. Project management plan updates
- C. Recommended corrective actions
- D. Performance reports
- E. Scope baseline updates

**Answer: D (LEAVE A REPLY)**

### NEW QUESTION: 258

Who is the person responsible for monitoring the risks, and implementing risk response plans if the risk event occurs?

- A. Risk Owner
- B. Risk Manager
- C. Project Manager
- D. The Customer

**Answer: A ([LEAVE A REPLY](#))**

**NEW QUESTION: 259**

Which of the following process involves determining project roles, responsibilities, and reporting relationships, and develops the staffing management plan?

- A. Human resource planning
- B. Develop project team
- C. Acquire project team
- D. Manage project team

**Answer: A ([LEAVE A REPLY](#))**

**NEW QUESTION: 260**

The schedule management plan is a key document. It is \_\_\_\_\_

- A. An output of the develop schedule process
- B. A tool and technique used in the develop schedule process
- C. The first time management process
- D. A separate planning effort completed in conjunction with the time management processes

**Answer: C ([LEAVE A REPLY](#))**

Explanation/Reference:

Explanation:

The schedule management plan is the output of plan schedule management, the first of the seven time management processes. It is a subsidiary plan to the project management plan.

**NEW QUESTION: 261**

Quality management deals with all of the following except:

- A. conformance to requirements/specifications
- B. satisfying the needs of the customer
- C. making products more desirable and luxurious
- D. Both 1) conformance to requirements/specifications, and 2) making products more desirable and luxurious
- E. Both 1) satisfying the needs of the customer, and 2) making products more desirable and luxurious

**Answer: C ([LEAVE A REPLY](#))**

**NEW QUESTION: 262**

Risk can be divided into two basic types; business risk and pure (or insurable risk). Of the following, which one(s) fall(s) under business risk?

- A. Direct property loss and profit loss.
- B. personnel-related loss
- C. liability loss
- D. direct property loss
- E. profit loss

**Answer: E ([LEAVE A REPLY](#))**

**NEW QUESTION: 263**

The major reason why a project manager would use written instead of oral communication is:

- A. feedback
- B. All of the other alternatives apply.
- C. barrier elimination
- D. cost
- E. documentation

**Answer: ([SHOW ANSWER](#))**

**NEW QUESTION: 264**

You are the project manager for a construction company tasked with constructing an office building. Which tool will you use to bring together prequalified stakeholders and subject matter experts to learn about their expectations and attitudes about your project?

- A. Facilitated workshops
- B. Brainstorming
- C. Focus Groups
- D. Nominal Group technique

**Answer: ([SHOW ANSWER](#))**

**NEW QUESTION: 265**

A project manager discovers an enhancement that will improve the design being developed by a subject matter expert (EME). what should the project manager do?

- A. Disregard the enhancement, as no changes are allowed.
- B. Ask the change control board (CCB) to review the enhancement.
- C. Ask the expert to implement the enhancement.
- D. Document this discovery, and present it to all stakeholders.

**Answer: B ([LEAVE A REPLY](#))**

**NEW QUESTION: 266**

A project manager is leading an agile team. The daily standups and iteration meetings are currently facilitated by the product owner. A team member contacts the project manager and mentions that they are looking to improve their facilitation skills.

How should the project manager respond to this request?

- A. Ask the team member to review the lessons learned on facilitation from previous projects.

- B. Suggest that the team member facilitate an upcoming iteration and review the outcomes in the iteration retrospective.
- C. Engage their functional manager to determine if there is alignment to their development plan before agreeing.
- D. Add new elements to the project backlog to account for the training needs of the team member.

**Answer: C ([LEAVE A REPLY](#))**

#### **NEW QUESTION: 267**

You are the project manager for a major logistics installation project and must obtain specific services from local sources external to your project. Your subcontracts administrator has told you to prepare a product or service description, which is referenced in a \_\_\_\_\_

- A. Project statement of work
- B. Contract scope statement
- C. Request for proposal
- D. Contract

**Answer: ([SHOW ANSWER](#))**

Explanation/Reference:

Explanation:

The project statement of work describes in a narrative form the products, services, or results that the project will deliver. It references the product scope description as well as the business need and strategic plan.

#### **NEW QUESTION: 268**

A risk that arises as a direct result of implementing a risk response is called a:

- A. secondary risk
- B. potential risk
- C. residual risk
- D. contingent risk

**Answer: A ([LEAVE A REPLY](#))**

#### **NEW QUESTION: 269**

A project manager notices an unusually high rate of risks, but has limited resources to address them. To what should the project manager refer to determine risk priorities?

- A. Risk probability and Impact matrix
- B. Risk breakdown structure (RBS)
- C. Risk management plan Risk
- D. Risk mitigation strategy

**Answer: A ([LEAVE A REPLY](#))**

#### **NEW QUESTION: 270**

What are triple constraints of a project?

- A. Scope
- B. Cost
- C. All of the other alternatives apply
- D. Time

**Answer: C (LEAVE A REPLY)**

Projects triple constraints are 1) Scope, 2)Time and 3)Cost

### NEW QUESTION: 271

A complex project is divided into phases. The project manager is closing a minor phase when the project team realizes that one deliverable was not accepted by the audit department. The audit department was mistakenly not notified during this phase, but complained about the deliverable during the closure meeting.

What should the project manager do?

- A. Plan for the audit department to verify the deliverable again in the next phase.
- B. Analyze why the audit department was not included and ensure they are included in future phases.
- C. Plan for rework on this deliverable within this phase and get formal acceptance from the audit department.
- D. Obtain formal feedback from the audit department using a variance analysis to close the phase.

**Answer: (SHOW ANSWER)**

Section: Closing

**Valid PMP Dumps** shared by PrepPdf.com for Helping Passing PMP Exam! PrepPdf.com now offer the **newest PMP exam dumps**, the PrepPdf.com PMP exam **questions have been updated** and **answers have been corrected** get the **newest** PrepPdf.com PMP dumps with Test Engine here: <https://www.preppdf.com/PMI/PMP-prepaway-exam-dumps.html> (2045 Q&As Dumps, **40%OFF Special Discount: Exam-Tests**)

### NEW QUESTION: 272

What is the risk rating if the probability of occurrence is 0.30 and the impact if it does occur is moderate (0.20)?

- A. 0.03
- B. 0.06
- C. 0.10
- D. 0.50

**Answer: B (LEAVE A REPLY)**

Section: Initiation

**NEW QUESTION: 273**

Which of the following is a component of three-point estimates?

- A. Most likely
- B. Anticipated
- C. Expected
- D. Probabilistic

**Answer: A ([LEAVE A REPLY](#))**

**NEW QUESTION: 274**

At which stage of team development do members begin to work together, adjust work habits, and trust each other?

- A. Forming
- B. Storming
- C. Norming
- D. Performing

**Answer: ([SHOW ANSWER](#))**

Section: Executing

**NEW QUESTION: 275**

Your project files need to be sent via overnight mail to your company's central office. If the files do not arrive tomorrow, your company will not be able to deliver the project on time and you will lose an important client. The deadline cannot be negotiated. The team worked right up to the last minute in order to give you the files. Due to a traffic jam, you are running late and the overnight delivery company will close in five minutes. You can only make it if you drive over the speed limit. Which of the following is correct?

- A. You must drive over the speed limit so that you can save the client relationship
- B. You must stay within the speed limit, even if you lose the client
- C. You can use the earned value metrics to show that the SPI is over 1, meaning the project is not late
- D. You must negotiate a new deadline

**Answer: B ([LEAVE A REPLY](#))**

The PMP Code of Professional Conduct states that you must follow every law, no matter how trivial, and no matter how serious the consequences are. Any time that you see a question that asks about breaking a law, your answer should always be the choice that doesn't break it - no matter how minor the infraction, and how serious the consequences.

**NEW QUESTION: 276**

The primary result of effective team development is \_\_\_\_\_

- A. Improved project performance
- B. An effective, smoothly running team

C. An understanding by project team members that the project manager is ultimately responsible for project performance

D. Enhancement of the ability of stakeholders to contribute as individuals and team members

**Answer: (SHOW ANSWER)**

Section: Mix Questions

Explanation:

Improved project performance not only increases the likelihood of meeting project objectives, it also creates a positive team experience contributing to the enhancement of team capabilities. It results in improved teamwork, enhanced people skills and competencies, motivated employees, reduced staff turnover rates, and improved overall team performance.

**NEW QUESTION: 277**

Which of the following statements are FALSE regarding cost-reimbursable contracts?

A. cost-reimbursable contracts resemble fixed unit agreements when the unit rates are preset by the buyer and seller

B. cost-reimbursable contracts often includes incentives for meeting or exceeding project objectives

C. cost-reimbursable contracts are contracts that involves payments to the seller for actual costs, plus a fee representing the seller's profit

D. cost-reimbursable contracts generally carry the highest risks to the buyer, as the total costs are uncertain

**Answer: A (LEAVE A REPLY)**

**NEW QUESTION: 278**

Units of measure, level of precision, level of accuracy, control thresholds, and rules of performance measurement are examples of items that are established in the:

A. Work performance information.

B. Cost management plan.

C. Work breakdown structure.

D. Quality management plan.

**Answer: B (LEAVE A REPLY)**

**NEW QUESTION: 279**

As a result of a face-to-face meeting you recently had to discuss the items in your issues log, you have resolved issues and come away with an approved corrective action and an update to the project management plan. Which process does this describe?

A. Information Distribution

B. Manage Project Team

C. Manage Stakeholders

D. Performance Reporting

**Answer: (SHOW ANSWER)**

The two clues in this question are the face-to-face meetings (a communication method) and the resolved issues, which is an output of the Manage Stakeholders process.

**NEW QUESTION: 280**

You are managing a project with 23 team members and six key stakeholders. Two team members identify a problem with the current approach. Addressing that problem will require changes to the project plan and its subsidiary plans. One of the stakeholders previously indicated that any delays are unacceptable, and your team members tell you that it's possible the change could cause the team to miss at least one critical deadline. What is the BEST way to deal with this situation?

- A. Gather consensus among the team that you should make the change before approaching the stakeholders, so that they can see the team supports making the change.
- B. Deny the change because any delays are unacceptable.
- C. Analyze the impact that the change will have on the work to be done, the schedule and the budget.
- D. Make the change to the project plan and subsidiary plans, and ask the team to implement the change.

**Answer: C** ([LEAVE A REPLY](#))

Not every change needs to be made. Before you make any change, you always need to evaluate its impact on the triple constraint - time, cost and scope - and how those changes will affect the quality of the deliverables. Until you analyze that impact, there's no way to know whether or not it makes sense to make the change.

**NEW QUESTION: 281**

A stakeholder is requesting that the project manager share project status updates on a regular basis. This stakeholder is not included in the regular distribution list.

What should the project manager do?

- A. Ask the stakeholder's manager if the stakeholder can be added to the list.
- B. Start sending status updates to this stakeholder based on the request.
- C. Escalate the stakeholder's request to the project sponsor.
- D. Review the stakeholder engagement and communications management plans.

**Answer: (**[SHOW ANSWER](#)**)**

**NEW QUESTION: 282**

What is the lowest level in a WBS called?

- A. Work task
- B. Work unit
- C. Work activity
- D. Project task
- E. Work package

**Answer: (**[SHOW ANSWER](#)**)**

**NEW QUESTION: 283**

You are a project manager for Dakota Software Consulting Services. You're working with a major retailer that offers its products through mail-order catalogs. The company is interested in knowing customer characteristics, the amounts of first-time orders, and similar information. As a potential bidder for this project, you worked on the RFP response and submitted the proposal. When the selection committee received the RFP responses from all the vendors bidding on this project, it used a weighted system to make a selection. Which process did this occur in?

- A. Request Seller Responses
- B. Select Sellers
- C. Plan Contracting and Purchases
- D. Contract Administration

**Answer: B (LEAVE A REPLY)**

Select Sellers involves the receipt of bids and proposals. Weighted systems are one of the tools and techniques of this process used to evaluate vendors based on selection criteria defined by the organization.

**NEW QUESTION: 284**

A project management office (PMO) asks a project manager to calculate a project's contingency reserves. What should the project manager do?

- A. Check the total cost and add a reserve to cover quality issues.
- B. Ask the PMO to increase the budget according to company policies.
- C. Review the risk management plan.
- D. Add a percentage to cost based previous experience.

**Answer: C (LEAVE A REPLY)**

**NEW QUESTION: 285**

Which of the following techniques may be used on a project to resolve conflicts?

- A. Controlling, forcing, compromise, withdrawal
- B. Directing, forcing, compromise, confrontation
- C. Controlling, directing, compromise, confrontation, smoothing
- D. Forcing, smoothing, compromise, confrontation, withdrawal

**Answer: D (LEAVE A REPLY)**

**NEW QUESTION: 286**

You are in the process of defining how to plan and execute the risk management activities for your project. Which of the following statements are FALSE?

- A. The output of this process is the risk management plan
- B. The inputs to this process include the project scope statement and project management
- C. The tools/ techniques of this process are checklist analysis and diagramming techniques
- D. You are in the risk management planning process

Answer: ([SHOW ANSWER](#))

**Valid PMP Dumps** shared by PrepPdf.com for Helping Passing PMP Exam! PrepPdf.com now offer the **newest PMP exam dumps**, the PrepPdf.com PMP exam **questions have been updated** and **answers have been corrected** get the **newest** PrepPdf.com PMP dumps with Test Engine here: <https://www.preppdf.com/PMI/PMP-prepaway-exam-dumps.html> (2045 Q&As Dumps, **40%OFF Special Discount: Exam-Tests**)

**NEW QUESTION: 287**

Reverse analysis is a tool/ technique in II of the following processes EXCEPT:

- A. Activity resource estimation
- B. Cost estimation
- C. Cost budgeting
- D. Activity duration estimation
- E. Risk monitoring and control

Answer: ([SHOW ANSWER](#))

**NEW QUESTION: 288**

Communication Planning involves determining the information and communications needs of the stakeholders;

who needs what information, when they will need it, how it will be given to them and by whom. If you are going to start Communication Planning for your project, which of the following will facilitate this process?

- A. Knowledge of Constraints and Assumptions
- B. Availability of a Communications Management Plan
- C. Compilation of all Change Requests for the project
- D. Availability of Project Records and Project Reports

Answer: ([SHOW ANSWER](#))

**NEW QUESTION: 289**

A Project Manager has been contracted by a company to manage the development of a software business application. The Project Manager discovers that five of the software developers are contractors and do not have legal software licenses. What should the Project Manager do in this case?

- A. Report this to the company's senior management
- B. Report this to PMI
- C. Call the software vendor
- D. Fill out a software piracy report

Answer: ([SHOW ANSWER](#))

Section: Mix Questions

**NEW QUESTION: 290**

You are a project manager of ABC company and you are working for a large project with more than hundreds of stakeholders. Which of the following BEST course of action you are going to take?

- A. Consider needs of important stakeholders.
- B. Ask your manager to manage the stakeholders.
- C. Eliminate some of them.
- D. Consider needs of all stakeholders.

**Answer: D (LEAVE A REPLY)**

Consider needs of all stakeholders is the best choice.

**NEW QUESTION: 291**

A stakeholder frequently requests new functionalities to be included in the project. The stakeholder has submitted a new functionality improvement that will impact the project budget and schedule What should the project manager do?

- A. Update the change management plan
- B. Request that the project team expedite delivery of the project objectives based on the schedule
- C. Hold a meeting with the stakeholder and renegotiate the launch date
- D. Submit a change request to the change control board (CCB)

**Answer: D (LEAVE A REPLY)**

**NEW QUESTION: 292**

Which of the following are not the direct results of managing the project team?

- A. Recording the lessons learned
- B. Developing input to performance appraisals
- C. Resolving issues
- D. Negotiating staff assignments
- E. Submitting change request

**Answer: D (LEAVE A REPLY)**

**NEW QUESTION: 293**

What is a deliverable-oriented hierarchical decomposition of the work to be executed to accomplish the project objectives and create the required deliverables?

- A. Organizational Breakdown Structure (OBS)
- B. Work Performance Information
- C. Work Package
- D. Work Breakdown Structure (WBS)

**Answer: D (LEAVE A REPLY)**

Section: Planning

**NEW QUESTION: 294**

Which of the following statements describes quality control?

- A. Identifying relevant quality standards for the project.
- B. Monitoring specific project results to determine if they conform to relevant organizational quality standards.
- C. Evaluating the overall project performance on a regular basis.
- D. Taking action for increased efficiency of the project.

**Answer:** ([SHOW ANSWER](#))

**NEW QUESTION: 295**

To calculate the late start and late finish dates for a set of tasks , you must do:

- A. A backwards pass
- B. A forwards pass
- C. Both 1) An analysis of the critical path and 2) A backwards pass
- D. An analysis of the critical path

**Answer:** A ([LEAVE A REPLY](#))

**NEW QUESTION: 296**

With respects to the cost of quality, which of the following individuals was responsible for developing the "zero-defects" approach?

- A. Crosby
- B. Inshikawa
- C. Deming
- D. Juran

**Answer:** A ([LEAVE A REPLY](#))

**NEW QUESTION: 297**

During the implementation stage of a project. a newly appointed team leader approaches the project manager to verify the team's tasks and schedule. The work did not go as planned due to the team leader's lack of management experience. This could cause delays for the project.

What should the project manager do?

- A. Provide mentoring to the newly appointed team leader
- B. Directly manage the project team to avoid project delays
- C. Ask the human resources director to appoint a senior team leader
- D. Inform the project sponsor about the possible delay

**Answer:** A ([LEAVE A REPLY](#))

**NEW QUESTION: 298**

Which of the following is a key input to define activities?

- A. Project management plan
- B. Project scope management plan
- C. Schedule management plan
- D. Project management software

**Answer: C ([LEAVE A REPLY](#))**

Section: Mix Questions

Explanation:

While there are a number of inputs to define activities, the schedule management plan is a key input. It shows the level of detail necessary to manage the work.

#### **NEW QUESTION: 299**

Which Control Stakeholder Engagement tool or technique allows the project manager to consolidate and facilitate distribution of reports?

- A. Stakeholder analysis
- B. Data gathering and representation
- C. Work performance reports
- D. Information management systems

**Answer: D ([LEAVE A REPLY](#))**

#### **NEW QUESTION: 300**

An agile project is in the seventh iteration with multiple changes being accommodated from the project start due such as regulatory changes technological innovations market competition and other changes What should the project manager do to manage these continuous changes coming into the project?

- A. Leverage the product owner to monitor the external environment
- B. Suggest to the product owner to execute the changes in a separate project
- C. Ask the product owner to stop accommodating further changes to the scope
- D. Accommodate the critical and urgent changes in the current iteration

**Answer: B ([LEAVE A REPLY](#))**

#### **NEW QUESTION: 301**

Which process uses occurrence probability and impact on project objectives to assess the priority of identified risks?

- A. Perform Quantitative Risk Analysis
- B. Perform Qualitative Risk Analysis
- C. Identify Risks
- D. Plan Risk Management

**Answer: ([SHOW ANSWER](#))**

**Valid PMP Dumps** shared by PrepPdf.com for Helping Passing PMP Exam! PrepPdf.com now offer the **newest PMP exam dumps**, the PrepPdf.com PMP exam **questions have been updated** and **answers have been corrected** get the **newest** PrepPdf.com PMP dumps with Test Engine here: <https://www.preppdf.com/PMI/PMP-prepaway-exam-dumps.html> (2045 Q&As Dumps, **40%OFF Special Discount: Exam-Tests**)

**NEW QUESTION: 302**

You are working on a project and want to identify the cause of problems in a process by the shape and width of the distribution of the process variables. You should use a \_\_\_\_\_

- A. Histogram
- B. Pareto chart
- C. Scatter diagram
- D. Trend analysis

**Answer: A (LEAVE A REPLY)**

Section: Mix Questions

Explanation:

In a histogram, or a special form of bar chart, each column represents an attribute or characteristic of a problem or situation. The height of each column represents the relative frequency of the characteristic. It describes the central tendency, dispersion, or shape of a statistical distribution.

**NEW QUESTION: 303**

Which of the following statements are false regarding the administrative closure procedure?

- A. The administrative closure procedure is an output of the close project process
- B. The administrative closure procedure describes the procedure to transfer the project products or services to production and/ or operations
- C. The administrative closure procedure addresses the stakeholders approval requirements
- D. The administrative closure procedure addresses the terms and conditions of the contract for contract closure
- E. The administrative closure procedure addresses the completion or exit criteria for the project

**Answer: D (LEAVE A REPLY)**

**NEW QUESTION: 304**

What is the primary purpose of a milestone chart?

- A. To show resource constraints.
- B. To highlight the critical path.
- C. To show significant events in the project such as completion of key deliverables.
- D. To show task dependencies.

**Answer: C (LEAVE A REPLY)**

**NEW QUESTION: 305**

There has been a great delay in waiting to get the charter approved. It's finally complete and you are assigned as the Project Manager. Senior management wants you to begin planning as soon as possible. If you are in the process of planning the project, what is the best way to schedule Scope Verification?

- A. When the work of the project is done
- B. When the project management plan is awaiting signoff
- C. After the sponsor defines what they want the project to create
- D. At the end of every phase on the project

**Answer:** ([SHOW ANSWER](#))

**NEW QUESTION: 306**

A project is scheduled for implementation during the next three months. However, the key stakeholder wants to complete the project sooner in order to mitigate a regulatory compliance risk?

What should the project manager do?

- A. Crash the schedule
- B. Reprioritize project timelines and update the schedule.
- C. Fast track the schedule.
- D. Follow the change control process.

**Answer:** D ([LEAVE A REPLY](#))

**NEW QUESTION: 307**

Which of the following activities is not a part of administrative closure?

- A. Filtering information
- B. Gathering information
- C. Disseminating information
- D. Generating information

**Answer:** A ([LEAVE A REPLY](#))

**NEW QUESTION: 308**

Analogous cost estimating relies on which of the following techniques?

- A. Reserve analysis
- B. Vendor bid analysis
- C. Expert judgment
- D. Project management software

**Answer:** ([SHOW ANSWER](#))

**NEW QUESTION: 309**

A technique that can be used to measure the total income of a project compared to the total moneys expended at any period of time is:

- A. discounted cash flow (DCF)
- B. net present value (NPV) and discounted cash flow (DCF)
- C. return on investment (ROI)
- D. net present value (NPV)
- E. All of the other alternatives apply.

**Answer: E (LEAVE A REPLY)**

**NEW QUESTION: 310**

Which of the following are TRUE regarding Bidder conferences?

- A. Bidder conferences are tool/technique of request seller response process
- B. Bidder conferences are outputs of request seller response process
- C. Bidder conferences involves the receipt of bids or proposals and the application of the evaluation criteria in order to select a vendor
- D. Bidder conferences are meeting with prospective seller after preparation of bid or a proposal

**Answer: D (LEAVE A REPLY)**

**NEW QUESTION: 311**

Your management applies the 10 percent solution: It has requested that you reduce the budget for the project which you are currently initiating by 10%. What will this probably mean for your project?

- A. If the budget is cut by 10 percent, then the project will have an accompanying degradation of quality by 10 percent.
- B. If the project budget is an honest one, then a reduction in budget must be accompanied by a trade"off in either time or performance.
- C. A 10 percent reduction in budget will be accompanied by a loss of performance much less than the target reduction in cost.
- D. Most projects have "padded" estimates, and the budgetary reduction will force out the padding from the project.

**Answer: B (LEAVE A REPLY)**

**NEW QUESTION: 312**

Work performance information includes all the following EXCEPT \_\_\_\_\_

- A. Started deliverables
- B. Costs authorized and incurred
- C. Progress of deliverables
- D. Completed deliverables

**Answer: B (LEAVE A REPLY)**

Explanation/Reference:

Explanation:

Work performance information is an output of validate scope. It emphasizes deliverables whether or not they have started, their progress, and ones that have finished or have been accepted.

**NEW QUESTION: 313**

During execution of a project, the most common source of conflict within the project team is likely to be:

- A. Schedules
- B. Cost
- C. Technical opinions
- D. Priorities

**Answer: A ([LEAVE A REPLY](#))**

**NEW QUESTION: 314**

A company is transitioning their projects to utilize hybrid project management approaches. While putting together their project team, the project manager discovers the requirements from the customer are unclear and also realizes that the team members are lacking critical technical skills needed for project success. However, the customer will not accept any changes to the requirements. What should the project manager do to resolve this issue?

- A. Find and provide training to the project team members who do not have the required skills
- B. Ask the scrum master to refine the user stories to improve the team members' understanding
- C. Submit a change request to adapt the objectives of the project to the current situation
- D. Extend the duration of standup meetings to include skill transference from trained to untrained members

**Answer: A ([LEAVE A REPLY](#))**

**NEW QUESTION: 315**

A project is ready to complete the planning process, and all planning documents have been reviewed and approved by stakeholders. What should the project manager do next?

- A. Conduct a kick-off meeting.
- B. Create the schedule baseline.
- C. Acquire the resources.
- D. Determine the budget.

**Answer: A ([LEAVE A REPLY](#))**

Section: Planning

**NEW QUESTION: 316**

During a retrospective review, many project team members say they are not completing tasks during the iterations because of interruptions and requests for help from other teams. As a team facilitator, what should the project manager do to avoid this?

- A. Reunite with the project team members affected and tell them not to reduce the team's capacity.
- B. Hire a coach to help all project teams to improve their abilities to solve problems on their own.

C. Identify the problem's root causes and define the ground rules with all project team members to minimize interferences.

D. Recommend to the project team members that they should improve their planning and make their stories smaller.

**Answer:** ([SHOW ANSWER](#))

**Valid PMP Dumps** shared by PrepPdf.com for Helping Passing PMP Exam! PrepPdf.com now offer the **newest PMP exam dumps**, the PrepPdf.com PMP exam **questions have been updated** and **answers have been corrected** get the **newest** PrepPdf.com PMP dumps with Test Engine here: <https://www.preppdf.com/PMI/PMP-prepaway-exam-dumps.html> (2045 Q&As Dumps, **40%OFF Special Discount: Exam-Tests**)

**NEW QUESTION: 317**

After reviewing work performance information, the project manager discovers that the project is behind schedule. The project manager learns that two project team members are underperforming because they had issues working together on former projects. The project manager decides to break the team apart and form new teams.

What conflict resolution technique did the project manager use?

- A. Force/direct
- B. Withdraw/avoid
- C. Collaborate/problem solve
- D. Smooth/accommodate

**Answer:** ([SHOW ANSWER](#))

**NEW QUESTION: 318**

The duration of most activities will be significantly influenced by the resources assigned to them.

- A. False
- B. True

**Answer:** B ([LEAVE A REPLY](#))

**NEW QUESTION: 319**

During a project steering committee meeting, the project manager reports that a formerly supportive key team member has become resistant to and negative about changes. Where should this information be captured?

- A. Responsible, accountable, consult, and inform (RACI) matrix
- B. Stakeholders engagement assessment matrix
- C. Work performance reports
- D. Risk register and issue log

**Answer:** B ([LEAVE A REPLY](#))

**NEW QUESTION: 320**

In which of the following scope management processes are subject matter experts used?

- A. Scope verification
- B. Scope change control
- C. Initiation
- D. Scope planning
- E. Scope Definition

**Answer: C** ([LEAVE A REPLY](#))

**NEW QUESTION: 321**

What is an objective of the Developing Project Team Process?

- A. Feelings of trust and improved cohesiveness
- B. Ground rules for interaction
- C. Enhanced resource availability
- D. Functional managers become more involved.

**Answer: A** ([LEAVE A REPLY](#))

Section: Monitoring and Controlling

**NEW QUESTION: 322**

You have been assigned to a project in which the objectives are to direct customer calls to an interactive voice response system before being connected to a live agent. You are in charge of the media communications for this project. You report to the project manager in charge of this project and the VP of marketing, who share responsibility for this project. Which organizational structure do you work in?

- A. Balanced matrix organization
- B. Weak matrix organization
- C. Projectized organization
- D. Functional organization

**Answer: (SHOW ANSWER)**

Employees in a balanced matrix often report to two or more managers. Functional managers and project managers share authority and responsibility for projects. There is a balance of power between the functional managers and project managers.

**NEW QUESTION: 323**

Which risk analysis diagram is used to compare the relative importance and impact of variables that have a high degree of uncertainty to those that are more stable?

- A. Decision tree
- B. Tornado
- C. Ishikawa
- D. Monte Carlo

**Answer: (SHOW ANSWER)**

Section: Planning

**NEW QUESTION: 324**

In which of the following contract types does the buyer have the most cost risk?

- A. Cost plus fixed fee (CPFF)
- B. Cost plus incentive fee (CPIF)
- C. Cost plus award fee (CPAF)
- D. Cost plus percentage of costs (CPPC)

**Answer: D (LEAVE A REPLY)**

**NEW QUESTION: 325**

Project coordination is enhanced through progress reporting, variance reporting, and cross-team meetings. These are all forms of:

- A. stakeholder management.
- B. risk management and reporting.
- C. quality management.
- D. communications management.

**Answer: (SHOW ANSWER)**

When reporting performance and variance, we do it within the project team as well with stakeholders. I would like to consider stakeholder meetings as cross-team meetings to support my answer of "D". However, if the cross-team meetings are for non-project related teams for lessons' learned, then the activities in the question seem serves quality management.

**NEW QUESTION: 326**

Different types of project phases are used on projects, and each phase culminates in the completion of at least one deliverable. The high-level nature of these phases means they are an element of the project life cycle.

Some phases start before others complete. If this approach is followed, it may result in\_\_\_\_\_.

- A. An increase in the number of issues
- B. Increasing the schedule
- C. The need for a CCB
- D. More rework

**Answer: D (LEAVE A REPLY)**

Section: Mix Questions

Explanation:

The question is an example of an overlapping relationship between phases. It is used to compress the schedule through fast tracking as an example. By overlapping phases more resources may be needed, risks may increase, and more rework may result if a significant phase progresses before accurate information is available from the previous phase.

**NEW QUESTION: 327**

Two people at work are discussing roles and responsibilities as they relate to the company and the projects it has. They are discussing the role of the Project Manager and the Functional Manager.

What is the main role of the Functional Manager?

- A. To control resources
- B. To manage the project when the Project Manager isn't available
- C. To define business processes
- D. To manage the Project Managers

**Answer: A ([LEAVE A REPLY](#))**

Section: Mix Questions

**NEW QUESTION: 328**

In a project steering committee meeting, a few stakeholders raise concerns that the project manager's report shows that the outcome of the project is already in the market while the project is still in development. The project manager explains that the project is being delivered in sprints and involves different releases.

What should the project manager do to avoid a reoccurrence of this scenario?

- A. Ensure the content of the project report is clearly understood and request any necessary feedback.
- B. Ensure that all product features are completed as per the communicated specifications before releasing to market.
- C. Invite critical stakeholders to the daily project review meetings to ensure their full engagement and involvement.
- D. Send a detailed report to each steering committee member ahead of the meeting.

**Answer: A ([LEAVE A REPLY](#))**

**NEW QUESTION: 329**

During the stages of team development, your team is in which stage when there is problem solving and interdependence along with achievement and synergy?

- A. Storming
- B. Forming
- C. Norming
- D. Performing

**Answer: ([SHOW ANSWER](#))**

Explanation/Reference:

Explanation:

The performing stage of team development is noted by a theme of productivity. Management skills involve consensus building, problem solving, decision making, and rewarding, with

leadership shown through management by walking around, stewardship delegation, mentoring, being a futurist, and being a cheerleader/champion.

**NEW QUESTION: 330**

You are currently the project manager for a software development project, developing a next generation data-mining tool. Your team is developing a new software product that will help customers better manage large volumes of data, especially for data reporting purposes. The CEO tells you that the project must be completed within 18 months. In order to meet these strict deadlines you are currently in the process of estimating the duration of project plan activities, devising the project schedule, and monitoring and controlling deviations from the schedule. Which of the following Project Management Knowledge Areas are you involved in?

- A. Project Scope Management
- B. Project Quality Management
- C. Project Integration Management
- D. Project Risk Management
- E. Project Time Management

**Answer: E (LEAVE A REPLY)**

**NEW QUESTION: 331**

Who has more control in a strong matrix organization?

- A. Sponsor
- B. Project Manager
- C. Senior Manager
- D. Functional Manager

**Answer: B (LEAVE A REPLY)**

The project manager has control power in a strong matrix organization. A strong matrix gives the most authority to the project manager

**Valid PMP Dumps** shared by PrepPdf.com for Helping Passing PMP Exam! PrepPdf.com now offer the **newest PMP exam dumps**, the PrepPdf.com PMP exam **questions have been updated** and **answers have been corrected** get the **newest** PrepPdf.com PMP dumps with Test Engine here: <https://www.preppdf.com/PMI/PMP-prepaway-exam-dumps.html> (2045 Q&As Dumps, **40%OFF Special Discount: Exam-Tests**)

**NEW QUESTION: 332**

Please select the correct order for the five project management process groups?

- A. Feasibility, planning, executing, controlling and closing
- B. Initiating, planning, executing, planning & controlling, and closing
- C. Initiating, executing, planning, monitoring & controlling and closing

- D. Initiating, planning, elaboration, controlling and closing
- E. Planning, initiating, executing, controlling and closing

**Answer: B ([LEAVE A REPLY](#))**

**NEW QUESTION: 333**

An input to the Plan Procurement Management process is:

- A. Market research.
- B. Source selection criteria.
- C. A records management system.
- D. A stakeholder register.

**Answer: ([SHOW ANSWER](#))**

**NEW QUESTION: 334**

Which of the following statements are FALSE regarding weighting and screening systems?

- A. Screening systems establish minimum requirements for performance for one or more evaluation criteria when selecting a prospective seller
- B. None of the choices are correct
- C. Weighting systems are methods for quantifying quantitative data to minimize any biases when performing seller selection
- D. Weighting systems and screening systems are tool/ techniques of request seller responses process

**Answer: D ([LEAVE A REPLY](#))**

**NEW QUESTION: 335**

You have been asked to select between three projects. Project A has a net present value of \$54,750 and will take six months to complete. Project B has a net present value of \$85,100 and will take two years to complete. Project C has a net present value of \$15,000 and a benefit-cost ratio of 5:2. Which project should you choose?

- A. Project A
- B. There is not enough information to decide
- C. Project B
- D. Project C

**Answer: C ([LEAVE A REPLY](#))**

The idea behind net present value (or NPV) is that you can compare potential projects by figuring out how much each one is worth to your company right now. A project's NPV is figured out by coming up with how much the project is worth, and then subtracting how much it will cost. If you're asked to choose between projects and given the NPV of each of them, choose the one with the biggest NPV. That means you're choosing the one with the most value!

**NEW QUESTION: 336**

You are the project manager at an auto manufacturer. Due to the recent rise in the cost of petroleum, the market demand for hybrid cars with high fuel efficiency has increased. Your company has identified the multi-billion dollar market opportunity for highly fuel efficient vehicles. However, your organization does not have enough resources and expertise to exploit this opportunity. Hence, your organization has decided to identify the qualified candidates. Which of the following best describes the type of strategy you are using to deal with this market opportunity?

- A. Enhance
- B. Exploit
- C. Share
- D. Acceptance
- E. Avoidance

**Answer:** ([SHOW ANSWER](#))

**NEW QUESTION: 337**

What is the schedule performance index (SPI) if the planned value (PV) is \$100, the actual cost (AC) is \$150, and the earned value (EV) is \$50?

- A. 1.50
- B. 0.67
- C. 2.00
- D. 0.50

**Answer:** D ([LEAVE A REPLY](#))

**NEW QUESTION: 338**

Your project multiple functions. If this decision is made, your project will be terminated by: to create a new time tracking and accounting system has been put on hold pending a decision to bring in a third party human resources system that will handle

- A. Integration
- B. Extinction
- C. Subtraction
- D. Starvation

**Answer:** ([SHOW ANSWER](#))

**NEW QUESTION: 339**

The issue log is useful in control communications because it \_\_\_\_\_

- A. Provides what has happened and is a platform for subsequent communications
- B. Includes the project's risk register
- C. Organizes and summarizes information gathered
- D. Serves as an information management system for communications management

**Answer:** A ([LEAVE A REPLY](#))

Explanation/Reference:

Explanation:

The issue log is an input to control communications and is used to document and monitor issue resolution.

It can facilitate communications and ensure a common understanding of issues. In this process its information provides a repository of what already has happened in the project and serves as a platform for subsequent communications to be delivered. PMI®, PMBOK® Guide, 2013, 305

**NEW QUESTION: 340**

You are managing a large construction project that's been broken down into sub-projects (or phases). Each of these sub-projects is scheduled to take between three and six months to complete. At the end of each subproject, you plan to go through the closing processes and document lessons learned. Which of the following BEST describes what you must do at the beginning of each sub-project or phase?

- A. Use the Earned Value Technique to decide whether or not to finish the project
- B. Make sure you don't involve the team, to avoid introducing too much project management overhead
- C. Develop the preliminary scope statement for the phase
- D. Release all resources from the project and contact sellers to renegotiate all contracts

**Answer: C (LEAVE A REPLY)**

When you have a project that's broken up into sub-projects or phases, it's important that you perform the Initiating processes at the beginning of the project. Answer B is the one that best describes something that happens during the processes in the Initiating group developing the preliminary project scope statement.

**NEW QUESTION: 341**

In a project management team meeting, one of the team members always argues with the project manager about the objective, timeline, and deliverable of any assigned task.

What should the project manager do to manage this conflict?

- A. Talk to the project sponsor about the team member's attitude.
- B. Schedule a one-on-one meeting with the team member to talk about it and get their cooperation.
- C. Schedule a meeting with the team member and their manager to discuss the issue.
- D. Find another person to replace this team member.

**Answer: B (LEAVE A REPLY)**

**NEW QUESTION: 342**

On the electric company project the government implemented a regulatory change associated with the electricity sub-station upgrade project that required the company to spend an additional \$400,000 US on the project. This type of cost and activity best relates to which of the following?

- A. Risk management

- B. Management reserve
- C. Unknown unknowns
- D. Known unknowns

**Answer: C (LEAVE A REPLY)**

**NEW QUESTION: 343**

The CPI on your project is 0.44, which means that you should\_\_\_\_\_

- A. Place emphasis on improving the timeliness of the physical progress
- B. Reassess the life-cycle costs of your product, including the length of the life-cycle phase
- C. Place emphasis on improving the productivity by which work was being performed
- D. Recognize that your original estimates were fundamentally flawed, and your project is in an atypical situation

**Answer: (SHOW ANSWER)**

Section: Mix Questions

Explanation:

CPI = EV/AC. It measures the efficiency of the physical progress accomplished compared to the baseline. A CPI of 0.44 means that for every dollar spent, you are only receiving 44 cents of progress. Therefore, something is not correct with how you planned your project, or your original estimates were fundamentally flawed, and your project is in an atypical situation. You might want to reconsider a formal "replan" and/or take a new baseline of your project.

**NEW QUESTION: 344**

When large or complex projects are separated into distinct phases or subprojects, all of the Process Groups would normally be:

- A. divided among each of the phases or subprojects.
- B. repeated for each of the phases or subprojects.
- C. linked to specific phases or subprojects.
- D. integrated for specific phases or subprojects.

**Answer: B (LEAVE A REPLY)**

Section: Executing

**NEW QUESTION: 345**

Three-Point Estimates includes \_\_\_\_\_.

- A. Optimistic
- B. Pessimistic
- C. All other alternatives apply
- D. Most likely

**Answer: C (LEAVE A REPLY)**

Three-Point Estimates includes Most likely, Optimistic and Pessimistic.

**NEW QUESTION: 346**

A project manager develops a project's risk breakdown structure (RBS) divided into four categories. The team identifies a quality problem with one of the project deliverables. In what category should this risk be included?

- A. Technical
- B. External
- C. Organizational
- D. Project management

**Answer: D** ([LEAVE A REPLY](#))

**Valid PMP Dumps** shared by PrepPdf.com for Helping Passing PMP Exam! PrepPdf.com now offer the **newest PMP exam dumps**, the PrepPdf.com PMP exam **questions have been updated** and **answers have been corrected** get the **newest** PrepPdf.com PMP dumps with Test Engine here: <https://www.preppdf.com/PMI/PMP-prepaway-exam-dumps.html> (2045 Q&As Dumps, **40%OFF Special Discount: Exam-Tests**)

**NEW QUESTION: 347**

One of the team members is always late to the daily standup meeting. What should the project manager do?

- A. Schedule the meeting at the end of the day to accommodate everyone.
- B. Ignore the situation since the team member is accomplishing their deliverables.
- C. Reinforce the ground rules for standup meetings with the entire team.
- D. Speak with the team member directly to reinforce the ground rules.

**Answer: D** ([LEAVE A REPLY](#))

**NEW QUESTION: 348**

The consulting company has created the scope of work for the project. They are in the process of creating a schedule and budget. They have added time into the schedule for the delays that always happen. They are also allocating money into the budget for more computers and software that are usually needed beyond what is initially forecast. These items are an example of what?

- A. Unknown unknowns
- B. Known unknowns
- C. Risk management
- D. Management reserve

**Answer: B** ([LEAVE A REPLY](#))

Section: Mix Questions

**NEW QUESTION: 349**

Which of the following statement regarding WBS are true?

- A. Work include in the WBS is considered outside the scope of the project

- B. For productivity reasons, the WBS should be organized in the hierarchy that models the organizational hierarchy
- C. The lowest level in a WBS is called a work activity
- D. Each item in the WBS is generally assigned a unique identifier that can provide a means to track costs and resources
- E. The WBS is an output of scope definition process

**Answer:** ([SHOW ANSWER](#))

**NEW QUESTION: 350**

You are in the process of controlling changes to the project schedule. All of the following are outputs of this process EXCEPT:

- A. Schedule model data
- B. Performance measurements
- C. Schedule baseline updates
- D. Activity list updates
- E. Schedule model data updates

**Answer:** ([SHOW ANSWER](#))

**NEW QUESTION: 351**

Which phase of the project life cycle typically has the highest uncertainty and risk associated with it?

- A. concept
- B. conclusion
- C. All of the other alternatives apply.
- D. execution
- E. development

**Answer:** A ([LEAVE A REPLY](#))

**NEW QUESTION: 352**

A contractor estimates that a project has a 0.5 probability of \$200,000 profit and 0.3 probability of \$50,000 loss. The expected monetary value of this project is:

- A. \$85,000
- B. \$50,000
- C. \$150,000
- D. \$200,000
- E. None of the other alternatives apply .

**Answer:** A ([LEAVE A REPLY](#))

**NEW QUESTION: 353**

Which tool or technique is used in Close Procurements?

- A. Contract plan

- B. Procurement plan
- C. Closure process
- D. Procurement audits

**Answer: D ([LEAVE A REPLY](#))**

Section: Executing

**NEW QUESTION: 354**

Status of deliverables, implementation status for change requests, and forecasted estimates to complete are examples of:

- A. Work performance information.
- B. Organizational process assets.
- C. Enterprise environmental factors.
- D. Earned value management.

**Answer: A ([LEAVE A REPLY](#))**

**NEW QUESTION: 355**

Which of the following statements are true regarding proposals EXCEPT:

- A. Proposals can combine the technical (approach) and commercial (price) sections, which must be evaluated together.
- B. Proposals are output of the Request Seller Response process
- C. Proposals are seller-prepared documents that describes the seller ability to provide requested services
- D. Proposals are considered a formal and legal response/ offer to a buyer's request

**Answer: ([SHOW ANSWER](#))**

**NEW QUESTION: 356**

Who is responsible for decide project management process for a particular project?

- A. Sponsor
- B. Project Manager
- C. Stakeholders
- D. Senior management

**Answer: B ([LEAVE A REPLY](#))**

Project Manager is responsible for decide project management process for a particular project.

**NEW QUESTION: 357**

You are project manager responsible for constructing a new sports arena for the upcoming Olympics. Construction begins on a project over a year ago. The stakeholders of the project want a status report on the performance of the project to date. You've obtained the following measurements:

BAC=500, PV=500, AC=200, EV=300, CPI=1.5

You believe the type of variances that have occurred on the project to date are typical expect these variances to continue throughout the project. Based on the information above, what is the ETC for the project?

- A. 333.33
- B. 250
- C. 400
- D. 133.33
- E. 200

**Answer: D ([LEAVE A REPLY](#))**

#### **NEW QUESTION: 358**

Under which type of contract does the seller receive reimbursement for all allowable costs for performing contract work, as well as a fixed-fee payment calculated as a percentage of the initial estimated project costs?

- A. Cost Plus Fixed Fee Contract (CPFF)
- B. Cost Plus Incentive Fee Contract (CPIF)
- C. Firm Fixed Price Contract (FFP)
- D. Fixed Price with Economic Price Adjustment Contract (FP-EPA)

**Answer: A ([LEAVE A REPLY](#))**

Section: Monitoring and Controlling

#### **NEW QUESTION: 359**

Which of the following is an input to the Plan Risk Responses process?

- A. Risk register
- B. Schedule management plan
- C. Organizational process assets
- D. Risk urgency assessment

**Answer: A ([LEAVE A REPLY](#))**

#### **NEW QUESTION: 360**

You are in charge of developing a new product for a bank. Your quality metrics are based on the 80th percentile of each of the last three products developed. This is an example of:

- A. Statistical sampling
- B. Operational definitions
- C. Metrics
- D. Benchmarking

**Answer: ([SHOW ANSWER](#))**

#### **NEW QUESTION: 361**

The performance measurement baseline consists of all the following EXCEPT \_\_\_\_\_

- A. Scope baseline

- B. Requirements baseline
- C. Schedule baseline
- D. Cost baseline

**Answer: (SHOW ANSWER)**

Explanation/Reference:

Explanation:

The scope, schedule, and cost baselines may be combined into a performance measurement baseline. It also may include technical and quality parameters. It then is used as an overall project baseline against which project execution is compared to measure and manage performance. It also is used for earned value measurements.

**Valid PMP Dumps** shared by PrepPdf.com for Helping Passing PMP Exam! PrepPdf.com now offer the **newest PMP exam dumps**, the PrepPdf.com PMP exam **questions have been updated** and **answers have been corrected** get the **newest** PrepPdf.com PMP dumps with Test Engine here: <https://www.preppdf.com/PMI/PMP-prepaway-exam-dumps.html> (2045 Q&As Dumps, **40%OFF Special Discount: Exam-Tests**)

#### **NEW QUESTION: 362**

Table reporting, spreadsheet analysis, and presentations are examples of \_\_\_\_\_

- A. Project reports as an input to manage stakeholder engagement
- B. Work performance information as an output of control stakeholder engagement
- C. Tools and techniques used in control stakeholder engagement
- D. Updates from the plan stakeholder management process

**Answer: C (LEAVE A REPLY)**

Section: Mix Questions

Explanation:

In control stakeholder engagement, they are examples of distribution formats from information management systems, a tool and technique in this process. Such systems provide a structured tool for the project manager to capture, store, and distribute information to stakeholders about project cost, schedule progress, and performance. The project manager can use these systems to consolidate reports from several systems and facilitate report distribution.

#### **NEW QUESTION: 363**

A project manager is developing a high-level cost estimate for inclusion in the project charter. Since the project manager previously completed similar projects, what cost-estimating technique should be used?

- A. Bottom-up
- B. Expert judgment
- C. Analogous

D. Parametric

**Answer: B ([LEAVE A REPLY](#))**

**NEW QUESTION: 364**

Which of the following is an input to Develop Human Resource Plan?

- A. Team performance assessment
- B. Roles and responsibilities
- C. Staffing management plan
- D. Enterprise environmental factors

**Answer: D ([LEAVE A REPLY](#))**

Section: Planning

**NEW QUESTION: 365**

At the end of a project with multiple suppliers, the project manager is reviewing the closing process and finds that an unexpected financial balance is remaining. What will help the project manager understand why this has occurred?

- A. Lessons learned
- B. Organizational process assets
- C. Procurement audit
- D. Project audit

**Answer: D ([LEAVE A REPLY](#))**

**NEW QUESTION: 366**

In the past, the project manager and the project team performed well using predictive methodology. However, the organization recently decided to adopt agile approaches, and the project sponsor wants to use an agile approach in an upcoming project.

Before initiating the project, what should the project manager do?

- A. Make a request to human resources for new team members who have agile experience.
- B. Prepare a risk report that captures the probability and impact of risks, and then share it with the project sponsor.
- C. Share the organization's decision with the team and make plans to adopt an agile approach in the upcoming project.
- D. Ask the project sponsor to change the approach back to predictive as that is the team's strength.

**Answer: ([SHOW ANSWER](#))**

**NEW QUESTION: 367**

An organization is completing a critical milestone during the construction of residential properties. The project is fully sponsored by the government. Ten days prior to completion of this key project phase, affected community members begin a four-day protest causing the project to be put on hold.

What should the project manager do?

- A. Mitigate the risk.
- B. Increase effort on the project.
- C. Escalate the issue to the project sponsor
- D. Review the timeline

**Answer:** ([SHOW ANSWER](#))

**NEW QUESTION: 368**

A key stakeholder is concerned about a critical risk that may cause the project to run over budget. The project manager wants to share the mitigation plan with the stakeholder. What should the project manager do first?

- A. Review the risk register to identify the mitigation plan
- B. Check the organizational chart to determine the stakeholder's department.
- C. Consult the communications management plan to identify how to inform the stakeholder.
- D. Identify which deliverable in the work breakdown structure (WBS) will be affected by the risk

**Answer:** C ([LEAVE A REPLY](#))

**NEW QUESTION: 369**

Which of the following is a schematic display of the project's schedule activities and the logical relationships among them?

- A. Gantt chart
- B. Project schedule network diagram
- C. Project milestone list
- D. Activity list

**Answer:** B ([LEAVE A REPLY](#))

Section: Executing

**NEW QUESTION: 370**

A project has a senior stakeholder whose input is important, and who needs to be kept informed about the project's status. Rather than receive updates from the project manager, this stakeholder prefers to contact a team member directly. The stakeholder has a connection with this team member that is unrelated to the project, and thinks that this is a way to obtain inside information on the project's true status.

What should the project manager do?

- A. Ask the stakeholder how the additional information that they feel is missing from current communications may be provided.
- B. Keep the team member properly informed about project status so that the stakeholder receives the same information from both sources.
- C. Leave the connection in place, since the information coming via the team member is unofficial and will not create problems.

**D.** Tell the team member not to accept calls from the stakeholder, because these calls have an adverse effect on the team member's productivity.

**Answer:** ([SHOW ANSWER](#))

Section: Planning

Explanation/Reference:

**NEW QUESTION: 371**

Which type of contract is a hybrid of both a cost-reimbursable and a fixed-price contract?

- A.** Cost Plus Award Fee Contract (CPAF)
- B.** Cost Plus Incentive Fee Contract (CPIF)
- C.** Firm-Fixed -Price Contract (FFP)
- D.** Time and Material Contract (T&M)

**Answer:** ([SHOW ANSWER](#))

**NEW QUESTION: 372**

A project manager discusses a project's status with the customer. The customer expresses the need for a new system that is not part of the current project scope What should the project manager do next?

- A.** Inform the project sponsor of the cost and schedule impacts.
- B.** Update the project scope baseline and work breakdown structure (WBS).
- C.** Update the requirements management plan.
- D.** Evaluate the customer's needs as part of the Perform Integrated Change Control process.

**Answer:** ([SHOW ANSWER](#))

**NEW QUESTION: 373**

A multinational company is locally developing a digital product using a new technology platform. The only expert on this platform is located in the company's headquarters, and they are responsible for providing support to different countries.

How can the local project manager ensure the involvement of this expert?

- A.** Design a travel schedule so that timely, onsite assistance can be provided.
- B.** Ask the project sponsor to assign the expert as a full-time member of the team.
- C.** Include the expert on the team using a virtual environment.
- D.** Ask team members to contact the expert as an external expertise source on an as-needed basis.

**Answer:** **C** ([LEAVE A REPLY](#))

**NEW QUESTION: 374**

You are in the implementation phase of a project. At this point, which of the following is the lowest source of conflict for you?

- A.** Conflict over schedule and cost
- B.** Conflict over technical opinions

- C. Conflict over personality issues
- D. Conflict over personnel resources

**Answer:** ([SHOW ANSWER](#))

**NEW QUESTION: 375**

The current incremental revenue expected by a project deliverable is not fulfilling the business case requirement. The deliverable was already closed and handed over to the operations team. Which two actions should the project manager take? (Choose two)

- A. Report the issue to the product manager and business segments
- B. Schedule a project review meeting to analyze the root cause
- C. Review the issue with project sponsor and submit a change request
- D. Discuss the issue with the operations team to assess expense overruns
- E. Analyze the business benefits criteria and assumptions

**Answer:** ([SHOW ANSWER](#))

**NEW QUESTION: 376**

You are leading a research project that will require between 10 and 20 aerospace engineers. Some senior-level aerospace engineers are available. They are more productive than junior-level engineers, who cost less and who are available as well. You want to determine the optimal combination of senior- and junior-level personnel. In this situation, the appropriate technique to use is to \_\_\_\_\_

- A. Conduct a design of experiments
- B. Use the Ishikawa diagram to pinpoint the problem
- C. Prepare a control chart
- D. Analyze the process using a Pareto diagram

**Answer: A** ([LEAVE A REPLY](#))

Section: Mix Questions

Explanation:

This technique is used to identify which variables have the most influence. It is a statistical method to identify the factors that may influence specific variables of a product or process under development or in production.

For example, roller blade designers might want to determine which combination of number of wheels and titanium ball bearings would produce the most desirable "ride" characteristics at a reasonable cost. This technique, however, can be applied to project management issues such as cost and schedule trade-offs. An appropriately designed "experiment" often will help project managers to find an optimal solution from a relatively limited number of options, and often it helps to determine the number and type of tests to use and their impact on quality.

**Valid PMP Dumps** shared by PrepPdf.com for Helping Passing PMP Exam! PrepPdf.com now offer the **newest PMP exam dumps**, the PrepPdf.com PMP exam **questions have been updated** and **answers have been corrected** get the **newest** PrepPdf.com PMP dumps with Test Engine here: <https://www.preppdf.com/PMI/PMP-prepaway-exam-dumps.html> (2045 Q&As Dumps, **40%OFF Special Discount: Exam-Tests**)

**NEW QUESTION: 377**

Which of the following is an input to Direct and Manage Project Execution?

- A. Performance reports
- B. Project charter
- C. Outputs from planning processes
- D. Enterprise environmental factors

**Answer: (SHOW ANSWER)**

Section: Executing

**NEW QUESTION: 378**

Research has shown that during the execution phase of the project, the majority of conflicts involve \_\_\_\_\_

- A. Personalities
- B. Project priorities
- C. Cost
- D. Schedule

**Answer: D (LEAVE A REPLY)**

Section: Mix Questions

Explanation:

In a study of sources of conflict by project life-cycle phase, seven different causes of conflict were identified. In the execution phase, the highest-ranking sources of conflict were schedules, technical issues, and personnel, in this order, followed by priorities, administrative procedures, cost, and personalities.

**NEW QUESTION: 379**

A project manager for a software technology project works in a matrixed organization with virtual teams.

Unfortunately, the functional manager informs the project manager that there may not be any resources available to test the software.

What should the project manager do next?

- A. Engage with the functional manager to discuss details to obtain the required support.
- B. Request a teleconference meeting with the sponsor to submit a change request to allow the development team to conduct testing.

C. Discuss testing requirements at the weekly project meeting to negotiate the best approach to test software.

D. Send an email to the procurement specialist to negotiate with a company that specializes in software testing.

**Answer: C ([LEAVE A REPLY](#))**

#### **NEW QUESTION: 380**

Team development is based on the-

A. Project's organizational climate of cooperation, open communication, and trust

B. Individual development of each team member

C. Organizational structure of the project

D. Training provided to the project team

**Answer: B ([LEAVE A REPLY](#))**

#### **NEW QUESTION: 381**

A project manager recording project risks discovers that, in the past, the company's purchasing department experienced delays when purchasing critical project inputs. The project manager identifies that if this risk materializes it will increase the schedule by 50 percent.

What should the project manager do?

A. Reinforce the importance of this project to the purchasing department.

B. Analyze the situation, and develop a response strategy with the team.

C. Inform the sponsor, and execute the management reserve.

D. Update the schedule to accommodate the delay of critical inputs.

**Answer: B ([LEAVE A REPLY](#))**

Section: Executing

#### **NEW QUESTION: 382**

During the execution of a project, the project manager finds there are some initial requirements for each team member that have not been considered in the scope. What should the project manager do?

A. Speak with the human resources department to recruit new team members

B. Meet with the project sponsor to determine why these prerequisites were not included

C. Implement corrective actions approved by the change control board (CCB)

D. Establish a new baseline and update the project management plan

**Answer: ([SHOW ANSWER](#))**

Section: Executing

#### **NEW QUESTION: 383**

Which of the following best describes what is a workaround?

A. Workarounds are result of implementing a risk response

B. Workarounds are used for monitoring overall project performance against a baseline plan

- C. Workarounds are equivalent to corrective actions
- D. Workarounds are unplanned responses to risks that were previously unidentified or accepted
- E. Workarounds are ways to mitigate risk using avoidance, transfer, or risk mitigation

**Answer: D ([LEAVE A REPLY](#))**

**NEW QUESTION: 384**

A project manager notices that the response action for an identified issue is insufficient for solving the problem. What should the project manager do next?

- A. Inform the stakeholders about the failure and update the issue log
- B. Include the issue in the risk register and update the team
- C. Meet with the project team to find another solution
- D. Document the continuing issue and failed solution

**Answer: A ([LEAVE A REPLY](#))**

**NEW QUESTION: 385**

Which of the following tools is used in process analysis to determine the underlying causes of defects?

- A. Root cause analysis
- B. Assumptions analysis
- C. Cost-benefit analysis
- D. Quality metrics

**Answer: A ([LEAVE A REPLY](#))**

Section: Mix Questions

Explanation:

Determining the root cause of the problem means to determine the origin of the problem. What may appear to be the problem on the surface is often revealed, after further analysis, not to be the real cause of the problem. Process analysis includes root cause analysis used to identify a problem, discover the underlying causes that lead to it and develop preventive actions.

**NEW QUESTION: 386**

After reviewing the lessons learned database, a project manager realizes that the current team may not be knowledgeable enough about organizational processes for the needs of a new project. What should the project manager do?

- A. Ask a functional manager to provide the right team members.
- B. Develop the team members to work as a cross-functional team.
- C. Review the project charter to see if the scope can be modified.
- D. Ask the portfolio manager to reassign the project to another team.

**Answer: ([SHOW ANSWER](#))**

**NEW QUESTION: 387**

You are the project manager assigned to construct a new 10-story office building. You are trying to estimate the costs for this project. You start by assigning the costs associated with each of the project activity. Then you sum up all the individual costs into a final cost estimate. Which type of cost estimation technique did you use?

- A. Monte Carlo methods
- B. Bottom-up estimation
- C. Parametric estimation
- D. Analogous estimation

**Answer: B ([LEAVE A REPLY](#))**

#### **NEW QUESTION: 388**

A project is going through its iterative design stage. One of the team members has been performing poorly.

This is a critical project for the company and execution is about to start. What should the project manager do?

- A. Escalate the issue to the human resources manager and request that the team member be replaced
- B. Provide feedback and coach the team member during the iterative design stage
- C. Request action from the functional manager regarding the team members poor performance
- D. Avoid selecting the team member to the next project that has an iterative design stage

**Answer: ([SHOW ANSWER](#))**

#### **NEW QUESTION: 389**

A project is six months into project execution when a key stakeholder leaves the company and another person from the same functional area is assigned to the project. The project manager updates all project documentation with this information.

What should the project manager do before the next stakeholder's project review meeting?

- A. Send all of the project documents to the new stakeholder.
- B. Meet with the new stakeholder to introduce themselves and the team.
- C. Bring the new stakeholder up to date on any unresolved problems in project.
- D. Determine if the planned communications will meet the new stakeholder's needs.

**Answer: B ([LEAVE A REPLY](#))**

Section: Executing

#### **NEW QUESTION: 390**

You work for a large manufacturing plant. You are working on a new project to release an overseas product line. This is the company's first experience in the overseas market, and it wants to make a big splash with the introduction of this product. The stakeholders are a bit nervous about the project and historically proceed cautiously and take a considerable amount of time to examine information before making a final decision. The project entails producing your product in a concentrated formula and packaging it in smaller containers than the

- A. The question describes risk tolerance levels of the stakeholders, which should be considered as an input to the Risk Management Planning process.
- B. This question describes a risk that requires a response strategy from the positive risk category.
- C. This question describes risk triggers that are derived using interviewing techniques and recorded in the risk register during the Qualitative Risk Analysis process.
- D. This question describes the interviewing tool and technique used during the Risk Identification process.

**Answer: A (LEAVE A REPLY)**

This question describes risk tolerance levels of the stakeholders. Risk triggers are recorded in the risk register during the Risk Response Planning process. The risk of buying a machine from a new supplier would pose a threat to the project, not an opportunity. Interviewing might have been used, but this question wasn't describing the Risk Identification process.

### NEW QUESTION: 391

A proof of concept for a proposed solution was conducted during the project implementation, and it was determined that the current technology cannot support it. What should the project manager do next?

- A. Add this item to the issue log and explore possible resolution options with the team.
- B. Use a root cause analysis (RCA) technique like Ishikawa diagrams to determine why the current technology is not supportive.
- C. Ask another team member to redo the proof of concept using the current technology to ensure it is truly not an option.
- D. Update the risk register indicating that a new technology must be chosen by the team lead.

**Answer: (SHOW ANSWER)**

**Valid PMP Dumps** shared by PrepPdf.com for Helping Passing PMP Exam! PrepPdf.com now offer the **newest PMP exam dumps**, the PrepPdf.com PMP exam **questions have been updated** and **answers have been corrected** get the **newest** PrepPdf.com PMP dumps with Test Engine here: <https://www.preppdf.com/PMI/PMP-prepaway-exam-dumps.html> (2045 Q&As Dumps, **40%OFF Special Discount: Exam-Tests**)

### NEW QUESTION: 392

The person assigned by the performing organization to be responsible for achieving the project objectives is the:

- A. functional manager
- B. program manager
- C. project manager
- D. portfolio manager

**Answer: (SHOW ANSWER)**

Section: Closing

**NEW QUESTION: 393**

Which of the following is an output of Direct and Manage Project Execution?

- A. Contract
- B. Preliminary Scope Statement
- C. Work Performance Information
- D. Statement of Work

**Answer: C (LEAVE A REPLY)**

The two main outputs of Direct and Manage Project Execution are Deliverables and Work Performance Information. Deliverables are the documents and other work products your project produces, and Work Performance Information is a name for all of the performance metrics and reports you can generate to track how your project is doing versus your plan.

**NEW QUESTION: 394**

Assume that your actual costs are \$1,000; your planned value is \$1,200; and your earned value is \$1,500.

Based on these data, what can be determined regarding your schedule variance?

- A. At -\$300, the physical progress is being accomplished at a slower rate than is planned, indicating an unfavorable situation.
- B. At +\$300, the situation is favorable, as physical progress is being accomplished ahead of your plan.
- C. At +\$500, the situation is favorable, as physical progress is being accomplished at a lower cost than was forecasted.
- D. At -\$300, you have a behind-schedule condition, and your critical path has slipped.

**Answer: B (LEAVE A REPLY)**

Explanation/Reference:

Explanation:

Schedule variance is calculated as  $EV - PV$ , or  $\$1,500 - \$1,200 = +\$300$ . Because the SV is positive, physical progress is being accomplished at a faster rate than planned.

**NEW QUESTION: 395**

A project has a budget of US\$900. Its estimate to complete (ETC) is US\$600, the budget at completion (BAC) is \$US800, and the estimate at completion (EAC) is US\$1,200.

What is the management reserve?

- A. US\$100
- B. US\$200
- C. US\$300
- D. US\$400

**Answer: (SHOW ANSWER)**

Section: Planning

**NEW QUESTION: 396**

What is important for Quality auditors?

- A. They must be in-house personnel.
- B. They must be properly trained.
- C. They must be third-party staff.
- D. They must be mandated by the auditee.

**Answer: B** ([LEAVE A REPLY](#))

**NEW QUESTION: 397**

Which of the following is considered a direct cost for producing a widget?

- A. The salary of senior management and the project sponsor
- B. The labor costs of the workers who actually produced the widget.
- C. The rent for the building in which the widget was manufactured
- D. The cost of the materials used to produce a widget.
- E. Both 1) The cost of the materials used to produce a widget, and 2) The labor costs of the workers who actually produced the widget.

**Answer: E** ([LEAVE A REPLY](#))

**NEW QUESTION: 398**

A project manager uses a facilitator to gather opinions from experts anonymously. What tool or technique of Risk Identification is being performed?

- A. Delphi Technique
- B. Brainstorming
- C. Interviews
- D. SWOT Analysis

**Answer: A** ([LEAVE A REPLY](#))

The Delphi technique is a way to get opinions and ideas from experts. This is a technique that uses a facilitator who uses questionnaires to ask experts about important project risks. They take those answers and circulate them - but each expert is kept anonymous so they can give honest feedback.

**NEW QUESTION: 399**

Post mortem Earned value analysis of a project which is going to be closed showed the following data: SPI: 0.72 CPI: 1.00

What is this telling you?

- A. The entire work of the project has been finished behind schedule and on budget.
- B. The project has been terminated before completion. At that time it was ahead of schedule and on budget.
- C. The project has been terminated before completion. At that time it was behind schedule and on budget

D. The entire work of the project has been finished ahead of schedule and on budget.

**Answer: C ([LEAVE A REPLY](#))**

**NEW QUESTION: 400**

All of the following statements are true regarding the Human Resource Planning process except for which one?

A. A RAM (or RACI chart) is an output of this process that allows you to see all the people assigned to an activity.

B. One of the Human Resource Planning outputs includes project organization charts that show the project's reporting relationships.

C. The staffing management plan created in this process describes how and when resources will be acquired and released.

D. Human Resource Planning involves determining roles and responsibilities.

**Answer: A ([LEAVE A REPLY](#))**

The RAM and RACI charts are tools and techniques of this process.

**NEW QUESTION: 401**

You are the project manager at a biotech company, where you are leading a cross-functional team to develop a treatment for diabetes. The organization has a weak matrix structure, where all of your project team members report to different functional managers and none of the team members report to you directly. Your project has extremely high visibility in the company, and there is a lot of pressure on you to deliver on time and within budget. However, you are concerned whether you will have the necessary authority and power to complete the project deliverables. Which of the following types of powers will be MOST effective in your situation?

A. Legitimate power

B. Expert power

C. Punishment power

D. Referent power

**Answer: B ([LEAVE A REPLY](#))**

**NEW QUESTION: 402**

Which baselines make up the performance measurement baseline?

A. Scope baseline, cost baseline, and schedule baseline

B. Scope baseline, project management baseline, and quality baseline

C. Cost baseline, schedule baseline, and risk baseline

D. Cost baseline, project management baseline, and schedule baseline

**Answer: ([SHOW ANSWER](#))**

Section: Monitoring and Controlling

**NEW QUESTION: 403**

The project is going through quality assurance. Which of the following is a key tool that will be utilized in this process?

- A. Quality management plan
- B. Quality testing
- C. Quality audits
- D. Quality improvement

**Answer: C ([LEAVE A REPLY](#))**

#### **NEW QUESTION: 404**

A project manager is running a complex transformation project with teams located in multiple time zones and with different cultures. Previous experience has taught the project manager that significant friction may occur with distributed teams. What should the project manager do to improve collaboration?

- A. Search for previous lessons learned for similar projects and select the best strategy
- B. Log this as a key risk and assign a full-time person to monitor the situation closely
- C. Ask the sponsor if an experienced external company can be appointed to identify the best approach.
- D. Include previous team members in the project team and use their experience

**Answer: A ([LEAVE A REPLY](#))**

#### **NEW QUESTION: 405**

You are working on a project and discover that one of the business users responsible for testing the product never completed this activity. She has written an email requesting that one of your team members drop everything to assist her with a problem that could have been avoided if she would have performed the test. This employee reports to a stakeholder, not to the project team. All project team members and stakeholders are colocated. Since your team needs her to also participate in an upcoming test, you decide to do which of the following?

- A. You decide to have a face-to-face meeting with the stakeholder because this is the most effective means for resolving issues with them.
- B. You decide to record the issue in the issue log and bring it up at the next status meeting. Everyone can benefit from understanding the importance of stakeholders fulfilling their roles and responsibilities on the project.
- C. You decide to record the issue in the issue log and then phone the stakeholder to explain what happened. You know speaking with the stakeholder directly is the most effective means for resolving issues.
- D. You decide to email the stakeholder and explain what happened in a professional manner because this is the most effective means for resolving issues with them.

**Answer: ([SHOW ANSWER](#))**

Face-to-face meetings are the most effective means for resolving stakeholder issues provided these meetings are practical.

**NEW QUESTION: 406**

Which quality tool may prove useful in understanding and estimating the cost of quality in a process?

- A. Flowcharts
- B. Histograms
- C. Control charts
- D. Checksheets

**Answer: A ([LEAVE A REPLY](#))**

**Valid PMP Dumps** shared by PrepPdf.com for Helping Passing PMP Exam! PrepPdf.com now offer the **newest PMP exam dumps**, the PrepPdf.com PMP exam **questions have been updated** and **answers have been corrected** get the **newest** PrepPdf.com PMP dumps with Test Engine here: <https://www.preppdf.com/PMI/PMP-prepaway-exam-dumps.html> (2045 Q&As Dumps, **40%OFF Special Discount: Exam-Tests**)

**NEW QUESTION: 407**

Approved change requests, approved corrective actions, and updates to organizational process assets are all outputs of which project management process?

- A. Scope definition
- B. Risk response planning
- C. Manage stakeholders
- D. Performance reporting

**Answer: C ([LEAVE A REPLY](#))**

**NEW QUESTION: 408**

A company has undertaken a large transformation project using agile practices. The project sponsor has asked the project manager to promote the new values identified in the intended transformation to the project team What should the project manager do?

- A. Add a user story during sprint planning that gives recognition to behaviors that are aligned with the new values
- B. Give recognition to team members' behaviors that are aligned with the new values during the sprint retrospectives
- C. Organize a team meeting focusing on the new values associated with the transformation
- D. Send a standard email to the team prior to every daily standup containing the new values

**Answer: A ([LEAVE A REPLY](#))**

**NEW QUESTION: 409**

A retail chain is evaluating a project to replace payment systems across all its stores in multiple locations The project does not pass the financial threshold but is also expected to increase

market share, improve customer services and retain more customers The project is planned as a phased implementation building on learning from the retrospectives during each phase How should the business increase the value of the project?

- A. Quantify the expected tangible and intangible benefits in the benefits management plan for each phase
- B. Consult with experts on methods to reduce costs and increase the financial value of the project
- C. Ask the benefits owner to reassess the identified risks that are impacting the outcomes of the financial benefits.
- D. Use a fishbone diagram to find the root cause of the lower financial benefits with the benefits owner

**Answer: A ([LEAVE A REPLY](#))**

#### **NEW QUESTION: 410**

Midway through implementation of a construction project, a supplier fails to deliver cement and jeopardizes the project schedule. The construction team leader asks the project manager to implement a contingency plan.

What action should the project manager take?

- A. Inform project stakeholders of the risk occurrence.
- B. Implement a workaround.
- C. Refer to the risk register.
- D. Brainstorm with the team

**Answer: ([SHOW ANSWER](#))**

Section: Monitoring and Controlling

Explanation/Reference:

#### **NEW QUESTION: 411**

In which Knowledge Area is the project charter developed?

- A. Project Cost Management
- B. Project Scope Management
- C. Project Time Management
- D. Project Integration Management

**Answer: ([SHOW ANSWER](#))**

Section: Initiation

#### **NEW QUESTION: 412**

A project can be defined as a:

- A. Temporary endeavor undertaken to create a unique product, service, or result
- B. Temporary endeavor that produces repetitive outputs
- C. Permanent endeavor undertaken to create a unique product, service, or result
- D. Permanent endeavor that produces repetitive outputs

**Answer: A ([LEAVE A REPLY](#))**

Section: Initiation

**NEW QUESTION: 413**

A project manager complains that the vendor obtained through the procurement process did not meet the project's requirements. The procurement department argues that the project manager did not provide adequate information when submitting the procurement documents. What should the project manager do?

- A. Compare the submitted procurement documents to the quality management plan requirements.
- B. Determine if there is sufficient time and funds to terminate the contract and then conduct a new procurement process.
- C. Escalate the problem to both the project sponsor and the procurement department director.
- D. Negotiate with the vendor on how the requirements can be met.

**Answer: D** ([LEAVE A REPLY](#))

**NEW QUESTION: 414**

Assigning more talented resources to the project to reduce time to completion or to provide better quality than originally planned are examples of which one of the following strategies?

- A. Enhance
- B. Exploit
- C. Share
- D. Contingent response

**Answer: B** ([LEAVE A REPLY](#))

Section: Mix Questions

Explanation:

Although it might have a negative connotation, exploitation is a strategy used for risks with positive impacts where the organization wants to ensure that the opportunity is realized.

**NEW QUESTION: 415**

A program is defined in the PMBOK as:

- A. A program consists of a related group of projects and Program management is the process of managing multiple on going projects
- B. A project plan developed by key management personnel to obtain a desired outcome
- C. A number of subprojects divided into manageable components enabling a project team to ensure the completion of a desired outcome
- D. The means to subdivide the project into manageable segments

**Answer: (SHOW ANSWER)**

A program consists of a related group of projects and Program management is the process of managing multiple on going projects

**NEW QUESTION: 416**

Effective communication occurs in groups as well as between individuals and is made up of several key components, such as the purpose of the message, the audience that you are delivering the message to, and the content of the message itself. One important area to consider when working with manage communications\_\_\_\_\_

- A. The choice of media
- B. How often to distribute the information
- C. The communications plan
- D. The project performance report structure

**Answer: (SHOW ANSWER)**

Section: Mix Questions

Explanation:

The choice of media, or the way you deliver the information is as important as what you say. It is important to determine when to communicate in writing versus orally, when to prepare an informal memo or when to use a formal report, and when to communicate face to face or by email, as examples.

#### **NEW QUESTION: 417**

A project manager assigned to an engineering construction project is receiving questions from the site engineers. Several questions are related to carrying out activities to meet timelines that compromise the work crew's safety. When reviewing these questions, the project manager realizes that the engineers do not feel empowered to make decisions.

How should the project manager address this?

- A. Ensure all engineers are aware that questions should only be submitted in their weekly reports.
- B. Reinforce to all engineers the company vision of a safety-first approach to project activities.
- C. Email the company vision to the engineers and tell them they need to meet deadlines
- D. Consult the previous project manager to discuss how they managed these questions.

**Answer: B (LEAVE A REPLY)**

#### **NEW QUESTION: 418**

Midway through implementation of a construction project, a supplier fails to deliver cement and jeopardizes the project schedule. The construction team leader asks the project manager to implement a contingency plan.

What action should the project manager take?

- A. Inform project stakeholders of the risk occurrence.
- B. Implement a workaround.
- C. Refer to the risk register.
- D. Brainstorm with the team

**Answer: A (LEAVE A REPLY)**

Section: Monitoring and Controlling

#### **NEW QUESTION: 419**

A project manager notices that the project is behind schedule because materials delivery was delayed. The procurement team informs the project manager that new government-imposed rules for the procurement of these materials caused this delay.

In what plan should these new rules be documented?

- A. Communications management
- B. Project management
- C. Procurement management
- D. Stakeholder engagement

**Answer: C** ([LEAVE A REPLY](#))

#### **NEW QUESTION: 420**

Which of the following techniques uses a weighted average duration estimate to calculate activity durations?

- A. Simulations
- B. PERT
- C. GERT
- D. CPM

**Answer: (**[SHOW ANSWER](#)**)**

#### **NEW QUESTION: 421**

What entity is assigned various responsibilities related to the centralized and coordinated management of those projects under its domain?

- A. Project management office
- B. Project team office
- C. Executive sponsor office
- D. Program management office

**Answer: A** ([LEAVE A REPLY](#))

Section: Initiation

**Valid PMP Dumps** shared by PrepPdf.com for Helping Passing PMP Exam! PrepPdf.com now offer the **newest PMP exam dumps**, the PrepPdf.com PMP exam **questions have been updated** and **answers have been corrected** get the **newest** PrepPdf.com PMP dumps with Test Engine here: <https://www.preppdf.com/PMI/PMP-prepaway-exam-dumps.html> (2045 Q&As Dumps, **40%OFF Special Discount: Exam-Tests**)

#### **NEW QUESTION: 422**

The below Pareto chart indicates defects in areas associated with billing a client for project services. Based on this Pareto analysis, which area, or areas, indicate the greatest opportunity for improvement?

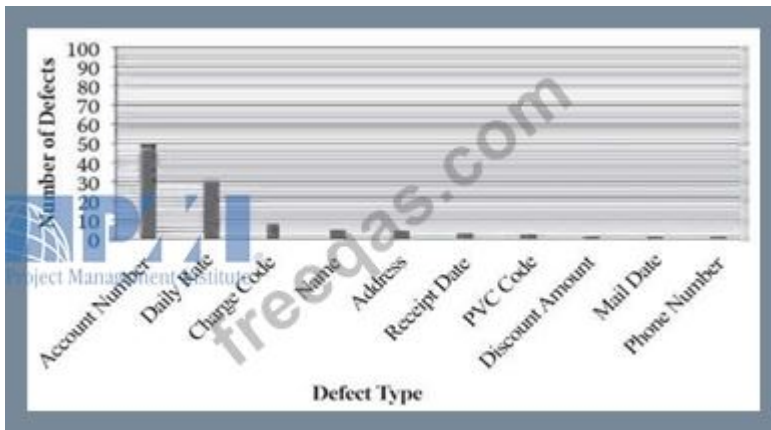

- A. The account number, because if it is incorrect, the invoice may be sent to the wrong client.
- B. The daily rate, because if it is incorrect, the total amount of the invoice will be wrong, which impacts the cash flow.
- C. The charge code, name, address, receipt date, pvc code, discount amount, mail date, and phone number, because they are fairly easy to confirm and correct, thereby significantly reducing the types of defects.
- D. The account number and daily rate, because they account for 80 percent of all defects.

**Answer: D (LEAVE A REPLY)**

Section: Mix Questions

Explanation:

Pareto analysis focuses on what Joseph Juran called the vital few. Named after Vilfredo Pareto, an Italian economist whose studies showed that 80 percent of the wealth was held by 20 percent of the population, quality analysis typically shows that 80 percent of the all problems (defects) are found in 20 percent of the items or areas studied.

#### NEW QUESTION: 423

A project leader is assigned to a new project and is asked to assemble an effective five-member agile team. If the project leader has no restrictions, which team should they choose?

- A. A team whose members have different skill sets and are spread out geographically
- B. A team whose members have more general aptitudes and can collaborate on different tasks
- C. A team whose members work independently and are the best subject matter experts (SMES)
- D. A team whose members have more general aptitudes but like to work individually

**Answer: B (LEAVE A REPLY)**

#### NEW QUESTION: 424

A project manager meets with the team to revise the change management plan A new sponsor disagrees with the project manager's idea to extend documentation to cover any possible changes throughout the projects life cycle The sponsor believes that all changes are welcome and should be accepted using an agile mindset.

What should the project manager do?

- A. Allow the new sponsor to guide the team to achieve project objectives.

**B.** Emphasize that any project change is welcome, but ask the project team not to discuss the project management plan in detail

**C.** Ask the new sponsor to formalize this with the management team and proceed with the planning session

**D.** Emphasize that any project change must be discussed and documentation updated

**Answer: C ([LEAVE A REPLY](#))**

**NEW QUESTION: 425**

As the Project Cost Engineer on a high rise development you are preparing your budget. You have developed a template, based on similar projects that can be used for buildings with 3-25 stories. It breaks out cost per square foot for plumbing, wiring, HVAC, dry wall, floors etc. This type of cost estimating is called:

**A.** Bottom up estimating

**B.** Analogous estimating

**C.** Spreadsheets

**D.** Parametric modeling

**Answer: ([SHOW ANSWER](#))**

**NEW QUESTION: 426**

The range of time allowed for an activity to be completed in is the \_\_\_\_\_.

**A.** Event.

**B.** Float time (LS - ES, or LF - EF).

**C.** Critical time (when ES = LS, or EF = LF).

**D.** Planned time (Duration).

**E.** Scheduled time (LF - ES).

**Answer: ([SHOW ANSWER](#))**

**NEW QUESTION: 427**

Tools and techniques used to perform quality assurance include\_\_\_\_\_

**A.** Tools from control quality and plan quality management

**B.** Tools from performance reporting

**C.** Variance analysis

**D.** Direct and manage project execution

**Answer: A ([LEAVE A REPLY](#))**

Section: Mix Questions

Explanation:

The tools used from plan quality management and control quality are used in perform quality assurance. The perform quality assurance process also uses affinity diagrams, process decision program charts, interrelationship digraphs, tree diagrams, prioritization matrices, activity network diagrams, matrix diagrams, quality audits, and process analysis.

**NEW QUESTION: 428**

Validate scope works hand-in-hand with control quality and generally follows control quality. A tool and technique used in validate scope that is not used in control quality is \_\_\_\_\_

- A. Group decision-making techniques
- B. Inspection
- C. Statistical sampling
- D. Variance analysis

**Answer: (SHOW ANSWER)**

Section: Mix Questions

Explanation:

Both processes use inspection. Validate scope also uses group-decision making techniques to reach a conclusion when the validation is performed by the project team and other stakeholders. Methods to reach a group decision include: unanimity, majority, plurality, and dictatorship.

**NEW QUESTION: 429**

You are finalizing all the contracts and ensuring that they are closed. The close procurements process involves all the following administrative actions EXCEPT \_\_\_\_\_

- A. The procurement administrator is reassigned
- B. Finalizing open claims
- C. Updating the project records to show the final contract results
- D. Archiving the contracts and contract records for future use

**Answer: A (LEAVE A REPLY)**

Section: Mix Questions

Explanation:

The close procurements process looks at the administration of the contract and not the people responsible or involved with the contract.

**NEW QUESTION: 430**

While inspecting a contractor's progress, the project manager notices that the contractor is behind schedule. The project manager speaks to the contractor who requests an extension.

What should the project manager do next?

- A. Verify the scope.
- B. Update the project schedule
- C. Conduct a performance review
- D. Issue a change request

**Answer: D (LEAVE A REPLY)**

**NEW QUESTION: 431**

During the deployment of a new system, an unexpected power outage occurs. What should the project manager do?

- A. Perform a qualitative risk analysis.

- B. Assess the risk probability and impact.
- C. Categorize the risk, and update the assumptions log.
- D. Refer to the risk register, and inform key stakeholders.

**Answer: B (LEAVE A REPLY)**

Section: Executing

**NEW QUESTION: 432**

The following is a network diagram for a project.



The critical path for the project is how many days in duration?

- A. 10
- B. 12
- C. 14
- D. 17

**Answer: D (LEAVE A REPLY)**

Section: Planning

**NEW QUESTION: 433**

The project manager is reviewing the program risks and issues with key stakeholders. One of the stakeholders wants to understand when the risk may potentially become an issue. What artifact should the project manager share with the stakeholder?

- A. Risk register
- B. Issue log
- C. Project management plan
- D. Risk management plan

**Answer: A (LEAVE A REPLY)**

**NEW QUESTION: 434**

You are the project manager for a two-year project that is now beginning its second year. The mix of team members has changed, and there is confusion as to roles and responsibilities. In addition,

several of the completed work packages have not received the required sign-offs, and three work packages are five weeks behind schedule. To gain control of this project, you need to \_\_\_\_\_

- A. Rebase line your original human resource plan with current resource requirements
- B. Change to a projectized organizational structure for maximum control over resource assignments
- C. Work with your team to prepare a responsibility assignment matrix
- D. Create a new division of labor by assigning technical leads to the most critical activities

**Answer: C (LEAVE A REPLY)**

Explanation/Reference:

Explanation:

The responsibility assignment matrix defines project roles and responsibilities in terms of work packages and activities. It can be used to show who is a participant, who is accountable, who handles review, who provides input, and who must sign off on specific work packages or project phases.

#### **NEW QUESTION: 435**

A project has been long and difficult. The team is relieved that the project is ending soon, and they begin to submit final reports before an approved one-week break. Overall, the project was successful. However, the project manager realizes that lessons learned were not recorded throughout the project.

Who should the project manager consult during the project to obtain lessons learned?

- A. Project specialist
- B. Junior project manager
- C. Quality assurance team
- D. Project team

**Answer: D (LEAVE A REPLY)**

Section: Closing

#### **NEW QUESTION: 436**

You are the project manager for the construction of an incinerator to burn refuse. Local residents and environmental groups are opposed to this project. Management agrees to move this project to a different location. This is an example of which one of the following risk responses?

- A. Passive acceptance
- B. Active acceptance
- C. Mitigation
- D. Avoidance

**Answer: D (LEAVE A REPLY)**

Explanation/Reference:

Explanation:

Risk avoidance involves changing the project management plan to eliminate the threat entirely.

**Valid PMP Dumps** shared by PrepPdf.com for Helping Passing PMP Exam! PrepPdf.com now offer the **newest PMP exam dumps**, the PrepPdf.com PMP exam **questions have been updated** and **answers have been corrected** get the **newest** PrepPdf.com PMP dumps with Test Engine here: <https://www.preppdf.com/PMI/PMP-prepaway-exam-dumps.html> (2045 Q&As Dumps, **40%OFF Special Discount: Exam-Tests**)

**NEW QUESTION: 437**

Where does comparing actual to baseline schedules, examining the statement of work, understanding cost overruns, and assessing risk all occur?

- A. Stakeholder meeting.
- B. Contract negotiation.
- C. Project audit.
- D. Resource leveling activity.

**Answer: C** ([LEAVE A REPLY](#))

**NEW QUESTION: 438**

A project manager is assigned to a new water treatment plant project that has been delayed for many years. It is revealed in the project charter that the sponsors of this project are from three different business units. This is the first time the sponsors have ever implemented such a project. What should the project manager do?

- A. Meet with the project sponsors to align expectations
- B. Schedule the project kick-off meeting immediately.
- C. Establish mentoring and coaching sessions.
- D. Review the knowledge repository for similar projects.

**Answer: A** ([LEAVE A REPLY](#))

**NEW QUESTION: 439**

The team is involved in defining what is needed to ensure that the quality process will capture the intended results of the testing. This is known as what?

- A. Quality assurance
- B. Measuring the output of the project
- C. Quality control
- D. Quality Management Planning

**Answer: (**[SHOW ANSWER](#)**)**

**NEW QUESTION: 440**

Which of the following calculates the difference between the budget at completion and estimate at completion?

- A. SV
- B. EAC
- C. CV
- D. EV
- E. VAC

**Answer:** ([SHOW ANSWER](#))

**NEW QUESTION: 441**

Which of the following is the process of identifying the specific actions to be performed to produce the project deliverables?

- A. Estimate Activity Durations
- B. Sequence Activities
- C. Define Activities
- D. Activity Attributes

**Answer: C** ([LEAVE A REPLY](#))

Section: Initiation

**NEW QUESTION: 442**

For complex procurement items, often contract negotiation can be an independent process. An example of an input if such a process is used is \_\_\_\_\_

- A. Open items list
- B. Approved changes
- C. Documented decisions
- D. Expert judgment

**Answer: A** ([LEAVE A REPLY](#))

Section: Mix Questions

Explanation:

Issues or an open item list are examples of inputs if contract negotiation is an independent process.

Outputs are documented decisions. While contract negotiations may need to be a separate process for complex procurements, for simple procurement items, the terms and conditions of the contract can be fixed and nonnegotiable.

**NEW QUESTION: 443**

You are the project manager at a large investment bank. Your current project involves developing a creative financing solution for a large bio-tech company in order to facilitate the acquisition of another company. Specifically, your project involves issuing convertible debt securities in order to access a new pool of low-cost capital. This transaction is the largest ever convertible transaction in the bio-tech company. Unfortunately, your project is plagued by frequent changes to project charter. Who should be primary person responsible for deciding whether the changes to the project charter are necessary?

- A. Project sponsor
- B. Project manager
- C. Project team
- D. Change control board
- E. Stakeholders

**Answer: A ([LEAVE A REPLY](#))**

**NEW QUESTION: 444**

After gathering all the requirements for a project with dependencies on external stakeholders, the project team is finishing the second iteration. At this point, the project manager learns about a possible change in regulations that would prevent the product launch. What should the project manager do to realize benefits?

- A. Implement the changes
- B. Improve the team's velocity
- C. Add an entry in the risk log
- D. Review target benefits.

**Answer: D ([LEAVE A REPLY](#))**

**NEW QUESTION: 445**

Your project schedule has slipped by 2 weeks, and you have to take corrective action to bring the expected future schedule performance in line with the project plan. To identify the cause of the variation, corrective action will require:

- A. Schedule updates to the existing schedule
- B. Fast Tracking or Crashing the project
- C. Root cause Analysis
- D. Documenting and analyzing the Lessons learned

**Answer: C ([LEAVE A REPLY](#))**

**NEW QUESTION: 446**

Which process involves subdividing project deliverables and project work into smaller, more manageable portions?

- A. Develop Schedule
- B. Create WBS
- C. Estimate Activity Resources
- D. Define Scope

**Answer: ([SHOW ANSWER](#))**

Section: Planning

Explanation

**NEW QUESTION: 447**

You are in the process of creating a project plan for the launch of a new drug. While creating the plan, your Finance Manager provided some insights about marketing the new drug which was very beneficial to you. This shows that:

- A. Every stakeholder has skills and knowledge that can be used in developing the project plan.
- B. Functional groups like finance should always be involved in creation of project plans
- C. Finance professionals usually have good knowledge of marketing concepts
- D. None of the above

**Answer: A ([LEAVE A REPLY](#))**

#### **NEW QUESTION: 448**

The standard types of communication include all but

- A. Nonverbal
- B. Telepathic
- C. Written
- D. Verbal
- E. None of the other alternatives apply

**Answer: B ([LEAVE A REPLY](#))**

#### **NEW QUESTION: 449**

Which of the following best describes decomposition?

- A. Taking a deliverable and breaking it down into the smaller work packages so that it can be organized and planned
- B. Dividing work packages into deliverables that can be planned for.
- C. Waiting for a task to expire so that it can break down into smaller tasks
- D. Categorizing work packages

**Answer: A ([LEAVE A REPLY](#))**

Decomposition is the main tool for creating the WBS. It just means breaking the work down into smaller and smaller pieces based on how your company does the work until it is small enough to categorize and organize hierarchically.

#### **NEW QUESTION: 450**

Having worked previously on projects as a team member, you are pleased to now be the project manager to develop a new process to ensure that software projects in your IT Department are considered a success and are not late or over budget. However, many of your team members are new to the organization. As you work to establish a high-performing team, you realize the importance of \_\_\_\_\_

- A. Mentoring
- B. Coaching
- C. Moving quickly through the forming and storming stages
- D. Safeguarding information

**Answer: B ([LEAVE A REPLY](#))**

Section: Mix Questions

Explanation:

Many communications skills are common to both general management and project management. Coaching is one example. It is especially useful to develop the team to higher levels of competency and performance and helping people recognize their potential through empowerment and development. It is used to aid team members to develop or enhance their skills required to achieve project success.

**NEW QUESTION: 451**

Parametric Modeling and Analogous Estimating are used in what process:

- A. Cost Estimating Tools and Techniques
- B. Risk Analysis Outputs
- C. Cost Control Tools and Techniques
- D. Risk Analysis Tools and Techniques

**Answer: A (LEAVE A REPLY)**

**Valid PMP Dumps** shared by PrepPdf.com for Helping Passing PMP Exam! PrepPdf.com now offer the **newest PMP exam dumps**, the PrepPdf.com PMP exam **questions have been updated** and **answers have been corrected** get the **newest** PrepPdf.com PMP dumps with Test Engine here: <https://www.preppdf.com/PMI/PMP-prepaway-exam-dumps.html> (2045 Q&As Dumps, **40%OFF Special Discount: Exam-Tests**)

**NEW QUESTION: 452**

The project scope baseline should be used in the identify risks process because it \_\_\_\_\_

- A. Identifies project assumptions
- B. Identifies all work that must be done; therefore, it includes all risks on the project
- C. Helps organize all work that must be done on the project
- D. Contains information on risks from prior projects

**Answer: A (LEAVE A REPLY)**

Explanation/Reference:

Explanation:

Project assumptions, which should be enumerated in the project scope baseline in the scope statement, are areas of uncertainty, and therefore, potential causes of project risk.

**NEW QUESTION: 453**

A project team is conducting a retrospective. The team wants to identify what had a positive impact on the velocity and keep doing it.

Click on the area that the team should focus on to identify good practices.



Answer:



Explanation





**NEW QUESTION: 454**

A project manager is conducting agile release planning with their recently acquired team. They are committed to working together to deliver excellent results. The client asks for a product with limited requirements because of a lack of technical knowledge.

What should the project manager do to ensure that the client is satisfied with the final product?

- A. Add more features to the final product
- B. Have the client provide their own technical engineer
- C. Engage the client in every iteration
- D. Set the requirements in a signed contract

Answer: ([SHOW ANSWER](#))

**NEW QUESTION: 455**

According to a new product development process, the marketing department will begin adding business and user requirements directly into agile project documents. Drag the product information on the left to the correct documents on the right

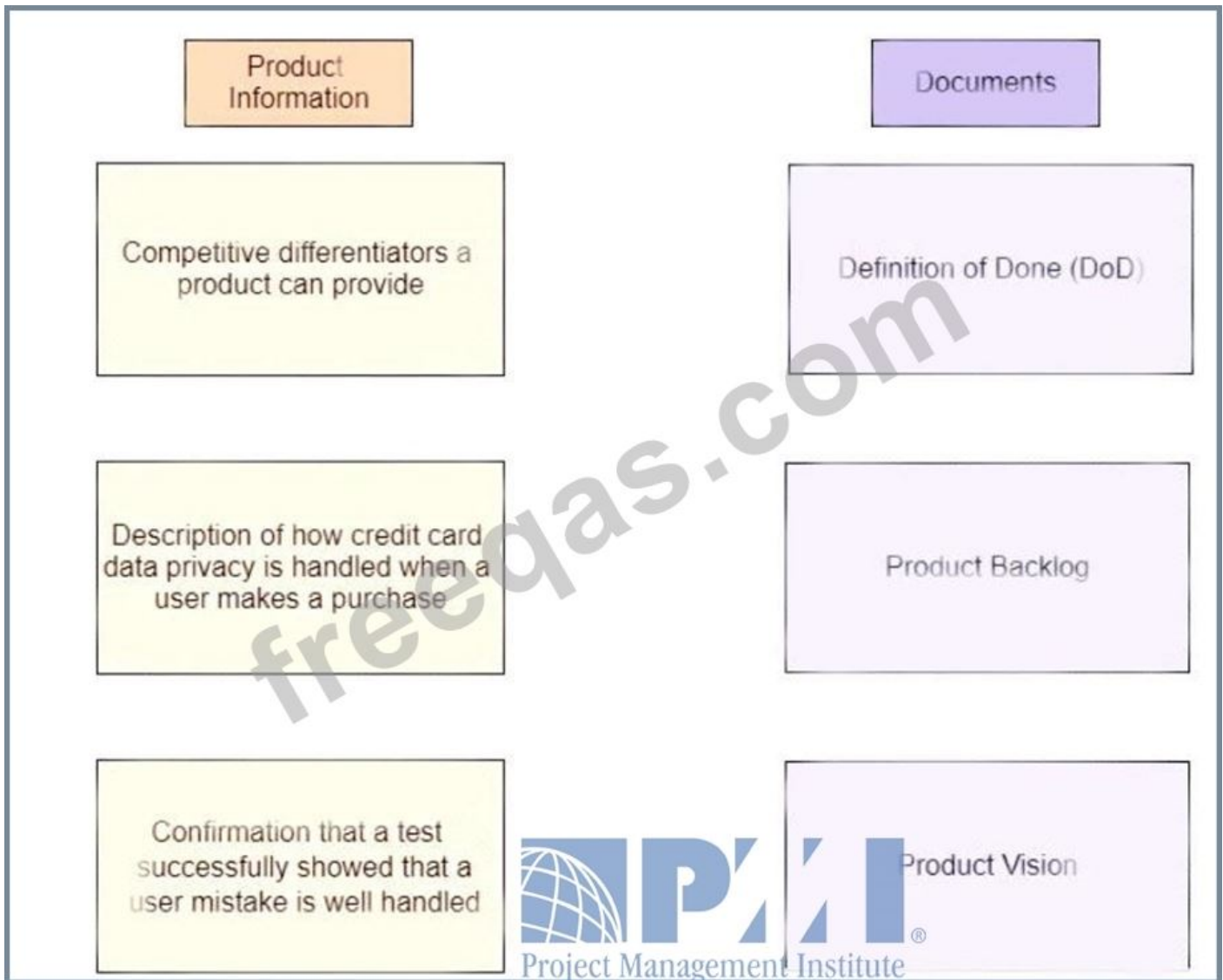

**Answer:**

Documents

Competitive differentiators a product can provide

Confirmation that a test successfully showed that a user mistake is well handled

Description of how credit card data privacy is handled when a user makes a purchase

Description of how credit card data privacy is handled when a user makes a purchase

Confirmation that a test successfully showed that a user mistake is well handled

Competitive differentiators a product can provide

Explanation



**NEW QUESTION: 456**

A joint venture project is waiting for legal closure. Further evaluation reveals that it critically conflicts with the agreement from another joint venture.

What should the project manager do next?

- A. Identify other project scenarios that do not conflict with the existing agreement.
- B. Notify the project sponsor, and recommend that the project be postponed until further review.
- C. Inform the project sponsor, escalate the issue to the legal department, and update the risk register.
- D. Continue with project closure while maintaining good communications with both joint ventures.

**Answer: C (LEAVE A REPLY)**

Section: Closing

**NEW QUESTION: 457**

A Project Manager has completed the Scope Definition process. The customer and sponsor have shortened the schedule by four weeks and decided that the work breakdown structure will be excluded.

What would be the best action the Project Manager should take?

- A. Provide the customer and sponsor an updated schedule and budget
- B. Begin execution of the project
- C. Discuss with the customer and sponsor the ramifications of excluding the WBS
- D. Call a meeting and notify the team of the change in schedule

**Answer: C ([LEAVE A REPLY](#))**

#### **NEW QUESTION: 458**

An agile senior project team member suddenly resigns from the organization. Following this departure, the remaining team members are having difficulty accessing information and are unable to complete a deliverable.

What should the project manager have done to avoid this situation?

- A. Provided specialist training for all team members.
- B. Made an effort to reemploy the senior project team member.
- C. Updated the job descriptions for all team roles.
- D. Ensured the project repository is up to date.

**Answer: D ([LEAVE A REPLY](#))**

#### **NEW QUESTION: 459**

A project manager has been managing a project for several months when an issue that had not been registered as a risk appeared. This issue may have a big impact on the project.

What should the project manager do?

- A. Hold a meeting with the project team and relevant stakeholders to agree on the best way to manage the issue
- B. Avoid managing the issue as it was not registered as a risk for the project and there is no planned response to it.
- C. Delay the project until the issue is addressed and no longer presents as a risk to the project.
- D. Inform the sponsor that the issue has arisen and that the project's success may be uncertain

**Answer: B ([LEAVE A REPLY](#))**

#### **NEW QUESTION: 460**

What two main knowledge areas are not listed in the execution process of the project, but rather a part of the controlling process?

- A. Quality and risk
- B. Cost and communication
- C. Schedule and cost
- D. Risk and procurement

**Answer: ([SHOW ANSWER](#))**

**NEW QUESTION: 461**

Drag the communication event on the left to the main subject discussed during the event on the right.

Communication event	Main subject
Daily meeting	Goal for this iteration
Iteration retrospective	Development flow
Iteration planning	Backlog items completed or not
Iteration review	Continue, stop, or start actions

**Answer:**

Communication event	Main subject
Daily meeting	Iteration planning
Iteration retrospective	Iteration review
Iteration planning	Daily meeting
Iteration review	Iteration retrospective

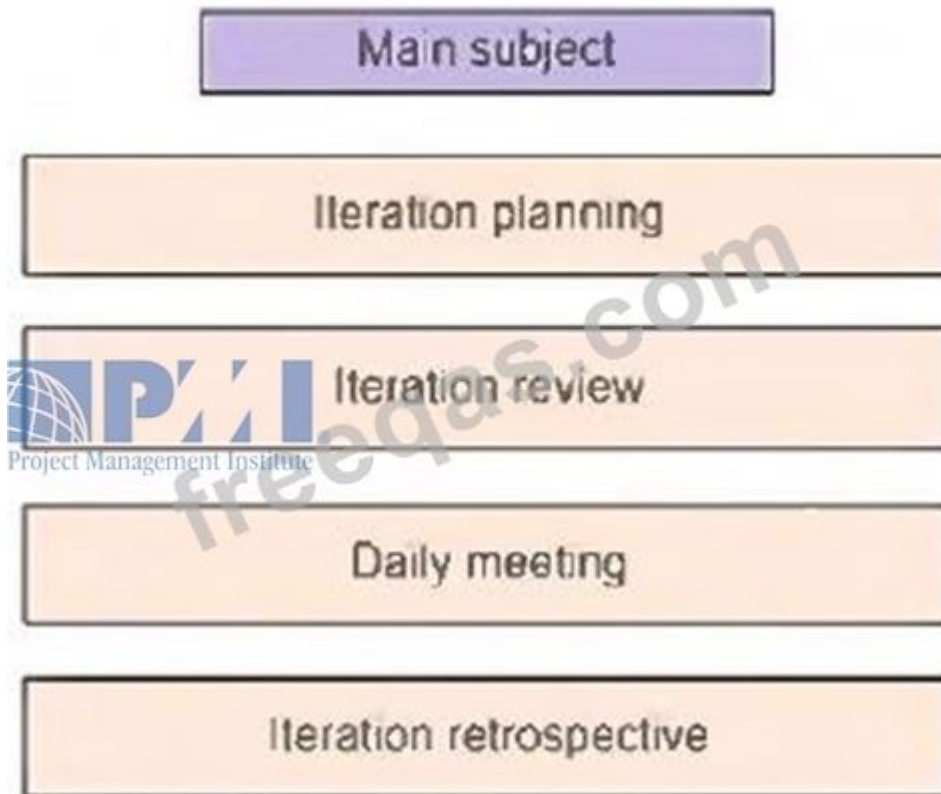

**NEW QUESTION: 462**

\_\_\_\_\_ is a receipt issued by a carrier for merchandise to be delivered to a party at some destination.

- A. Proforma invoice
- B. Packing list
- C. Bill of lading
- D. Inspection certificate
- E. None of the other alternatives apply .

**Answer: C ([LEAVE A REPLY](#))**

**NEW QUESTION: 463**

During which process would stakeholders provide formal acceptance of the completed project scope?

- A. Perform Quality Control
- B. Verify Scope
- C. Control Scope
- D. Develop Schedule

**Answer: ([SHOW ANSWER](#))**

Section: Closing

**NEW QUESTION: 464**

After project is completed, a complete set of indexed project records should be put in:

- A. Project Archives
- B. Project Reports
- C. Project Records
- D. Project Database

**Answer: A (LEAVE A REPLY)**

**NEW QUESTION: 465**

A project manager is using a hybrid approach for project delivery. The development team was sized, but is not yet fully resourced. The project manager is working on defining the project schedule.

What should the project manager do to address the issue of developer availability?

- A. Ask the resource manager when the new contractor is available to start and change the delivery date for the project schedule.
- B. Ask the sponsor to provide the desired completion date for project activities and complete the schedule.
- C. Organize a planning session with the development team and use their estimations to complete the schedule.
- D. Use expert judgment to estimate all of the tasks and complete the schedule in the allocated time.

**Answer: C (LEAVE A REPLY)**

**NEW QUESTION: 466**

A project team has a resource located outside of the country where the organization is based. This resource is assigned to an important deliverable that is due next month. The project manager just realized that this resource will have a long national holiday break close to the deliverable's due date. Therefore, there is a risk that the deliverable will not be completed on time.

What should the project manager do to mitigate this potential risk?

- A. Ask the resource to work during the national holidays to ensure the deliverable is completed on time.
- B. Ask the resource to travel to the organization's headquarters to complete the deliverable on time.
- C. Assign an additional resource who is capable of completing the deliverable on time.
- D. Inform stakeholders about the potential risk and delay of the resource's deliverable.

**Answer: D (LEAVE A REPLY)**

Section: Executing

**Valid PMP Dumps** shared by PrepPdf.com for Helping Passing PMP Exam! PrepPdf.com now offer the **newest PMP exam dumps**, the PrepPdf.com PMP exam **questions have been updated** and **answers have been corrected** get the **newest** PrepPdf.com PMP dumps with Test Engine here: <https://www.preppdf.com/PMI/PMP-prepaway-exam-dumps.html> (2045 Q&As Dumps, **40%OFF Special Discount: Exam-Tests**)

**NEW QUESTION: 467**

Calculate the standard deviation for the following: Pessimistic=20, Optimistic=10, Realistic=17.

- A. 6
- B. Not enough information
- C. 5.67
- D. 1.67

**Answer: (SHOW ANSWER)**

Section: Mix Questions

Explanation/Reference:

**NEW QUESTION: 468**

You are the project manager and responsible for quality audits. You have been accused of being a fanatic because of your practice of conducting not one, but multiple, quality audits on a project. Which one of the following types of audits is not an example of a quality audit?

- A. Internal
- B. Baseline
- C. System
- D. Scope

**Answer: D (LEAVE A REPLY)**

**NEW QUESTION: 469**

Risk score measures the \_\_\_\_\_

- A. Variability of the estimate
- B. Product of the probability and impact of the risk
- C. Range of schedule and cost outcomes
- D. Reduced monetary value of the risk event

**Answer: B (LEAVE A REPLY)**

Explanation/Reference:

Explanation:

The risk score provides a convenient way to compare risks because comparing impacts or probabilities alone is meaningless. It helps guide risk responses.

**NEW QUESTION: 470**

A project lifecycle is defined as:

- A. a recognized standard for the project management profession.
- B. the application of knowledge, skills, tools, and techniques to project activities to meet the project requirements.
- C. a process required to ensure that the project includes all the work required, and only the work required, to complete the project successfully.
- D. a collection of generally sequential and sometimes overlapping project phases.

**Answer:** ([SHOW ANSWER](#))

**NEW QUESTION: 471**

A company has hired a vendor to deliver a scope of work and assigned a project manager to oversee the project. The vendor advised that they completed the scope successfully and is asking for approval.

What should the project manager do in response to this request?

- A. Obtain approval from the project sponsor.
- B. Set up a meeting with stakeholders to validate and confirm acceptance of the deliverables.
- C. Update the project management plan and mark the milestone as completed.
- D. Ask the vendor to validate the agreement for any deviations.

**Answer:** B ([LEAVE A REPLY](#))

**NEW QUESTION: 472**

A key stakeholder is concerned about a critical risk that may cause the project to run over budget. The project manager wants to share the mitigation plan with the stakeholder.

What should the project manager do first?

- A. Check the organizational chart to determine the stakeholder's department.
- B. Review the risk register to identify the mitigation plan.
- C. Identify which deliverable in the work breakdown structure (WBS) will be affected by the risk.
- D. Consult the communications management plan to identify how to inform the stakeholder.

**Answer:** ([SHOW ANSWER](#))

Section: Executing

Explanation/Reference:

**NEW QUESTION: 473**

A company wants to launch a new product for customers. The project for this new product is in the development phase. Due to an uncertain environment, the project manager has doubts about the feasibility of the project.

What should the project manager do in this situation?

- A. Refer to the lessons learned to determine the impact on the external environment.
- B. Highlight the concern to the project sponsor in the next project review meeting,
- C. Recommend postponing the project until the uncertainty is resolved,
- D. Validate assumptions using appropriate tools to assess the risks.

**Answer:** ([SHOW ANSWER](#))

**NEW QUESTION: 474**

During the implementation phase of a project, functional managers are adding new requirements, which may impact cost and schedule baselines. The project manager notices that some of the team members are communicating with their managers directly to fulfill their requests.

This will lead the project to go beyond the agreed baselines.

How should the project manager handle this situation?

- A.** Follow the project constraints and move forward with the agreed schedule baseline and the cost baseline.
- B.** Ask the functional managers to communicate with their peers and emphasize the impact of their requirements.
- C.** Modify the communications management plan to enable functional managers to add changes to the project.
- D.** Set up a proper governance structure to ensure functional managers' requests are processed correctly.

**Answer: D** ([LEAVE A REPLY](#))

**NEW QUESTION: 475**

A project team completed the initial phase of the project and many team members do not have a clear understanding of the project management plan communication strategies and specific milestones. What should the project manager do?

- A.** Meet with team members as issues arise
- B.** Schedule periodic project status meetings
- C.** Schedule a kick-off meeting with all team members
- D.** Discuss concerns during the next stand-up meeting.

**Answer: C** ([LEAVE A REPLY](#))

**NEW QUESTION: 476**

You completed your stakeholder analysis. How do you want to manage those stakeholders that have a high interest in your project and high power over decisions affecting your project?

- A.** Manage them closely
- B.** Keep them satisfied
- C.** Keep them informed
- D.** Monitor them occasionally

**Answer: A** ([LEAVE A REPLY](#))

Explanation/Reference:

Explanation:

You must manage them closely. High-power/high-interest stakeholders who do not support your project could have a devastating effect on your project.

**NEW QUESTION: 477**

A natural disaster occurs that severely disrupts a project's progress. When should the project manager provide status updates to stakeholders?

- A. In accordance with the stakeholder engagement plan
- B. As needed and in line with the project charter
- C. As described in the communications channel diagram
- D. As soon as the mitigation plans are in place

**Answer:** ([SHOW ANSWER](#))

Section: Executing

#### **NEW QUESTION: 478**

You are the project manager at Construction Company, assigned to build 30-storey apartment building. In order to begin constructing the frame of the building, the foundation of the building must be built. Which of the following relationship types best describes this dependency between framing and foundation?

- A. Start-To-Finish
- B. Finish-To-Start
- C. Finish-To-Finish
- D. Start-To-Start

**Answer:** B ([LEAVE A REPLY](#))

#### **NEW QUESTION: 479**

A project manager is having difficulty acquiring final acceptance of some deliverables from a stakeholder for reasons that seem to be outside of the project acceptance criteria. What should the project manager do?

- A. Persuade this stakeholder using emotional intelligence skills to obtain acceptance.
- B. Escalate this issue to the project sponsor and ask for support in obtaining final stakeholder acceptance.
- C. Obtain final acceptance from another stakeholder who is also familiar with the project
- D. Create a project acceptance waiver noting the stakeholder's concerns so they can be addressed later

**Answer:** A ([LEAVE A REPLY](#))

#### **NEW QUESTION: 480**

A contract originated bilaterally may be developed by \_\_\_\_\_ .

- A. bid invitation release
- B. quotation request from suppliers
- C. All of the other alternatives apply.
- D. proposal request
- E. proposal request and bid invitation release

**Answer:** C ([LEAVE A REPLY](#))

### NEW QUESTION: 481

At the start of a project, the project sponsor sends an email to the entire project team. The email contains expectations of the implementation outcome that greatly exceed the approved business case and scope defined in the project charter.

Aiming to minimize the adverse impacts of this communication, what should the project manager do first?

- A. Meet with the project sponsor to understand their rationale and manage their expectations.
- B. Adjust the project charter to include these outcomes as objectives and address scope creep in the risk management plan.
- C. Send a reply-all response to this email with logical corrections and arguments to minimize misunderstandings.
- D. Host a kick-off workshop and invite all stakeholders to collect individual feedback and gain alignment.

**Answer: (SHOW ANSWER)**

Section: Monitoring and Controlling

Explanation/Reference:

**Valid PMP Dumps** shared by PrepPdf.com for Helping Passing PMP Exam! PrepPdf.com now offer the **newest PMP exam dumps**, the PrepPdf.com PMP exam **questions have been updated** and **answers have been corrected** get the **newest** PrepPdf.com PMP dumps with Test Engine here: <https://www.preppdf.com/PMI/PMP-prepaway-exam-dumps.html> (2045 Q&As Dumps, **40%OFF Special Discount: Exam-Tests**)

### NEW QUESTION: 482

The sponsor on the airport runway project has just told the Project Manager about a change he wants. He says that the change will cost 20% less and should not cause any problems to the existing environment. Which of the following should concern the Project Manager the most?

- A. Scope impact
- B. Schedule impact
- C. Quality impact
- D. Scope and schedule impact

**Answer: (SHOW ANSWER)**

Section: Mix Questions

### NEW QUESTION: 483

As project manager, you are primarily responsible for implementing the project management plan by authorizing the execution of project activities. Because you do not work in a projectized organization, you do not have direct access to human resource administrative activities.

Therefore you need to \_\_\_\_\_

- A. Outsource these functions
- B. Prepare a project team charter that is signed off by a member of the human resources department to delineate responsibilities
- C. Ensure that your team is sufficiently aware of administrative requirements to ensure compliance
- D. Ask the head of human resources to approve your project human resource plan personally

**Answer: (SHOW ANSWER)**

Explanation/Reference:

Explanation:

A projectized work environment is unusual because project managers rarely have every function under their control. But compliance with administrative requirements, government regulations, union contract provisions, and other constraints is a consideration in human resource management.

**NEW QUESTION: 484**

Your hardware vendor left you a voicemail saying that a snowstorm in the Midwest will prevent your equipment from arriving on time. You identified a risk response strategy for this risk and have arranged for a local company to lease you the needed equipment until yours arrives. This is an example of which risk response strategy?

- A. Transfer
- B. Acceptance
- C. Avoid
- D. Mitigate

**Answer: (SHOW ANSWER)**

Mitigation attempts to reduce the impact of a risk event should it occur. Making plans to arrange for the leased equipment reduces the consequences of the risk.

**NEW QUESTION: 485**

According to John R. Adams Ph.D., there are five sources of power that people have: legitimate, coercive, reward, expert and referent. If the team knows that the project manager who is managing the project is reporting straight up to the President, what type of power is most prevalent?

- A. Coercive
- B. Reward
- C. Referent
- D. Legitimate

**Answer: C (LEAVE A REPLY)**

**NEW QUESTION: 486**

Which is not an example of a correctly handled Contract closure procedure?

- A. Early termination of a contract because of an immaterial breach

- B. Product verification by stakeholders and administrative closure
- C. Settling and finally closing the contract agreement
- D. Early termination of a contract because of arepudiatory breach

**Answer: A ([LEAVE A REPLY](#))**

**NEW QUESTION: 487**

The core planning processes include:

- A. Scope definition, activity duration estimating, cost budgeting
- B. Scope planning, activity sequencing, communications planning
- C. Scope planning, activity definition, cost estimating, quality planning, risk response planning
- D. Quality planning, communications planning, risk response development

**Answer: ([SHOW ANSWER](#))**

**NEW QUESTION: 488**

A project is in the closure phase. The deliverables have been approved by the project sponsor. However the team that will support the delivered product is complaining about a lack of documentation.

What should the project manager have done to prevent this scenario?

- A. Released a change request to work on product documentation
- B. Communicated project closure processes formally
- C. Ensured all stakeholders were identified when defining the acceptance criteria.
- D. Showed the project sponsor the sign-off to convince them that they should accept the product

**Answer: C ([LEAVE A REPLY](#))**

**NEW QUESTION: 489**

During project execution, the risk owner is monitoring the critical speed rate of a power engine to eventually trigger the defined risk-response strategy. During the risk assessment and management process phase, it was defined that the power engine has the following characteristics

1,600 rpm (rate-per-minute) -> stops working and crashes the system

1.500 rpm (rate-per-minute) -> warns of max rate allowed

1.400rpm (rate-per-minute) -> reduces the power and brakes the engine

Which of the following statements is correct?

- A. 1600 rpm is a project issue; 1,500 rpm is a project risk; and 1,400 rpm is an event that triggers a response strategy
- B. 0 1,600 rpm is a project risk, 1,500 rpm is an event that triggers a response strategy and 1,400 rpm is a project issue.
- C. 1.600 rpm is an event that triggers a response strategy. 1,500 rpm is a project issue and 1,400 rpm is a project risk.
- D. 1,600 rpm is a project issue, 1,500 rpm is an event that triggers a response strategy and 1,400 rpm is a project risk

**Answer: A ([LEAVE A REPLY](#))**

**NEW QUESTION: 490**

A new project manager is planning an information security project for a company that resides in different countries. What is the first step the project manager should take to gather customer requirements?

- A. Conduct project planning meetings in one location with relevant stakeholders
- B. Request relevant stakeholders to conduct an analysis and reach consensus independently
- C. Conduct a stakeholder analysis to identify how regional policies may influence needs
- D. Conduct a project scope review workshop with relevant stakeholders.

**Answer: ([SHOW ANSWER](#))**

**NEW QUESTION: 491**

The purpose of a dummy activity in an activity-on-arrow diagram is to:

- A. Identify a task that could be replaced by another.
- B. Denote a milestone.
- C. Show a task that is not necessarily needed.
- D. Take the slack time into account.
- E. Show a dependency relationship.

**Answer: E ([LEAVE A REPLY](#))**

**NEW QUESTION: 492**

In a Lump-sum contract, the profit is:

- A. Provided by the buyer to the seller at end of project if defined performance criteria are met
- B. Determined by the seller during contract sign-off
- C. Not known at time of the contract sign-off
- D. Determined by the buyer during contract sign-off

**Answer: C ([LEAVE A REPLY](#))**

**NEW QUESTION: 493**

A project manager is appointed to manage an infrastructure project that spans across several countries, including different time zones within a subregion. It is likely that most of the project team members will never meet, but they will have to collaborate to ensure deliverables are met. What should the project manager do to ensure good collaboration between the remote project team members?

- A. Plan a communication method and allow the project team members to virtually interact.
- B. Set the ground rules and identify a contingency plan in the risk register.
- C. Discuss the concerns with the project sponsor and modify the project charter to include more budget for interactions.
- D. Create a social media group platform for the team to create a supportive environment.

**Answer: ([SHOW ANSWER](#))**

**NEW QUESTION: 494**

The project charter should be issued by

- A. The project manager
- B. Manager external to project
- C. Client requesting services
- D. Manager internal to the project

**Answer: B ([LEAVE A REPLY](#))**

**NEW QUESTION: 495**

You learn that a former boss of yours who is a PMP has committed to his boss that 100% of the PMO that he manages at their company will be certified. They also don't have any training budget, and can't send anyone to training to qualify for the training requirement for the exam. The other problem is that one of the people who passed the test is 22 years old and going to junior college.

You know that this person has been working in this area for only two years at most.

When asked about it, you are told that they lied about the experience hours and the training required of the PMP application. What is the best thing to do?

- A. Contact PMI to report the name(s) of the person(s), the name(s) of supervisor(s), and the company
- B. Contact your former boss and let him know it's not appropriate
- C. Tell your old boss to hire you back or you will turn them into PMI
- D. Ignore it because you don't work there anymore

**Answer: ([SHOW ANSWER](#))**

**NEW QUESTION: 496**

A product company is transforming the way it develops and releases products in the market. Executives believe that this is a high-risk initiative, and this initiative must be successful. What should the project manager do in this scenario?

- A. Adopt an iterative rollout approach that delivers the highest business value earlier
- B. Develop a business case with assumptions for the new model
- C. Develop a communications management plan to inform the employees about the new business model
- D. Develop a detailed sprint plan with clear deliverables

**Answer: A ([LEAVE A REPLY](#))**

**Valid PMP Dumps** shared by PrepPdf.com for Helping Passing PMP Exam! PrepPdf.com now offer the **newest PMP exam dumps**, the PrepPdf.com PMP exam **questions have been updated** and **answers have been corrected** get the **newest** PrepPdf.com PMP dumps with

**NEW QUESTION: 497**

A project committee reviews bidder proposals. Each committee member provides insights into their respective business functional areas. What tool or technique is the committee utilizing?

- A. Source selection criteria
- B. Procurement negotiations
- C. Expert judgment
- D. Data analysis

**Answer: A (LEAVE A REPLY)**

**NEW QUESTION: 498**

An experienced project manager is managing a multi-million dollar agile project. The project manager communicates the ground rules to the team, but after 12 iterations, the project manager starts noticing that some team members are not following the ground rules.

What should the project manager do first to ensure team adherence to the ground rules?

- A. Ask the functional manager to replace team members not following the ground rules
- B. Contact human resources to request a written warning letter be sent to team members not following the ground rules.
- C. Schedule a meeting with the project team to reinforce the ground rules.
- D. Notify the project sponsor about this behavior and ask the sponsor to take disciplinary action

**Answer: C (LEAVE A REPLY)**

**NEW QUESTION: 499**

The project sponsor is inappropriately requesting status reports from individual team members. The project manager plans to meet with the sponsor to discuss the issue.

To what should the project manager refer prior to the meeting?

- A. Communications management plan
- B. Risk management plan
- C. Project charter
- D. Work performance reports

**Answer: A (LEAVE A REPLY)**

Section: Monitoring and Controlling

**NEW QUESTION: 500**

Which of the following approaches is likely to lead to the MOST lasting solutions in cases of conflict resolution?

- A. Communicating
- B. Negotiating
- C. Problem-solving

- D. Smoothing
- E. Compromising

**Answer: C ([LEAVE A REPLY](#))**

**NEW QUESTION: 501**

A project manager has been assigned to a project that involves building 100 wells for a small community that is urgently in need of access to water. What should the project manager do next?

- A. Start project planning and develop the project management plan.
- B. Face the challenge immediately and start sending relief to the town.
- C. Process a change request for additional funding due to project urgency.
- D. Hire local contractors who are familiar with the environment.

**Answer: A ([LEAVE A REPLY](#))**

**NEW QUESTION: 502**

Which of the following are placed at selected points in the work breakdown structure (WBS) for performance measurement?

- A. Control accounts
- B. Milestones
- C. Management points
- D. Measurement points

**Answer: ([SHOW ANSWER](#))**

Section: Planning

**NEW QUESTION: 503**

A multimillion-dollar project has started and is in the execution phase. A local regulatory authority has just announced changes to the requirements that will need to be implemented in 6 months, prior to completing the project execution phase.

What should the project manager do next?

- A. Add the new requirements to the project scope immediately since they are mandatory changes.
- B. Ignore the new requirements as the current budget and schedule do not allow for any changes.
- C. Review the new requirements with the compliance department to determine if a change request is needed.
- D. Proceed with the defined project requirements and delay implementing the new requirements.

**Answer: C ([LEAVE A REPLY](#))**

**NEW QUESTION: 504**

Expert judgment is a tool/ technique in all of the following EXCEPT:

- A. Develop project management plan
- B. Scope planning
- C. Communications planning

- D. Develop project charter
- E. Develop preliminary project scope statement

**Answer: C ([LEAVE A REPLY](#))**

**NEW QUESTION: 505**

Which of the following is an input into the Develop Project Team process?

- A. Enterprise environmental factors
- B. Performance reports
- C. Organizational process assets
- D. Project staff assignments

**Answer: D ([LEAVE A REPLY](#))**

**NEW QUESTION: 506**

You are the project manager for a construction company that is building a new city and county office building in your city. You have calculated earned value measurements and found that the current CPI is 1.08 and the current SPI is 0.88. You are looking for options to reduce the project schedule. You look at the network diagram and start identifying the sequence of activities which can happen in parallel. Which technique are you using?

- A. Resource leveling
- B. Decomposition
- C. Crashing
- D. Fast Tracking

**Answer: D ([LEAVE A REPLY](#))**

**NEW QUESTION: 507**

During a project meeting, a stakeholder disagrees with a key deliverable and project milestone listed in the approved project charter. What should the project manager have done to prevent this?

- A. Engaged the stakeholder earlier
- B. Classified stakeholders using a power/interest grid
- C. Met more frequently with the stakeholder
- D. Conducted a thorough stakeholder analysis

**Answer: D ([LEAVE A REPLY](#))**

Section: Initiation

**NEW QUESTION: 508**

Assignable cause or special variation is:

- A. is indicated when a run of seven or more points fall above the center line of a standard control chart.
- B. is indicated when a point falls outside the control limits.
- C. is indicated when a point falls outside the specification limits.

D. 1) is indicated when a point falls outside the control limits, 2) is indicated when a run of seven or more points fall above the center line of a standard control chart, and 3) is indicated when a run of seven or more points fall below the center line of a standard control chart.

E. is indicated when a run of seven or more points fall below the center line of a standard control chart.

**Answer:** ([SHOW ANSWER](#))

**NEW QUESTION: 509**

Scope, schedule, and cost parameters are integrated in the:

- A. Summary of changes approved in a period,
- B. Performance measurement baseline.
- C. Analysis of past performance.
- D. Analysis of project forecasts,

**Answer:** B ([LEAVE A REPLY](#))

**NEW QUESTION: 510**

Inputs to the Plan Schedule Management process include:

- A. Organizational process assets and the project charter,
- B. Enterprise environmental factors and schedule tools.
- C. Time tables and Pareto diagrams.
- D. Activity attributes and resource calendars.

**Answer:** A ([LEAVE A REPLY](#))

Section: Planning

**NEW QUESTION: 511**

An output of the Close Project (or Close Phase) process is:

- A. work performance information
- B. accepted deliverables
- C. organizational process asset updates
- D. project management plan updates

**Answer:** ([SHOW ANSWER](#))

**Valid PMP Dumps** shared by PrepPdf.com for Helping Passing PMP Exam! PrepPdf.com now offer the **newest PMP exam dumps**, the PrepPdf.com PMP exam **questions have been updated** and **answers have been corrected** get the **newest** PrepPdf.com PMP dumps with Test Engine here: <https://www.preppdf.com/PMI/PMP-prepaway-exam-dumps.html> (2045 Q&As Dumps, **40%OFF Special Discount: Exam-Tests**)

**NEW QUESTION: 512**

The process of identifying and documenting project roles, responsibilities, required skills, and reporting relationships and creating a staffing management plan is known as:

- A. Develop Project Team.
- B. Manage Project Team.
- C. Acquire Project Team.
- D. Plan Human Resource Management.

**Answer: D (LEAVE A REPLY)**

Section: Planning

**NEW QUESTION: 513**

Key stakeholders disagree about the details in the project charter that describe how to deliver project requirements. What tool or technique should the project manager use to resolve this issue and obtain project charter approval?

- A. Expert judgement
- B. Facilitation
- C. Focus groups
- D. Decision making

**Answer: B (LEAVE A REPLY)**

Section: Monitoring and Controlling

**NEW QUESTION: 514**

After performing the program evaluation and technique (PERT), the following information was produced.

Estimate type	Duration (hours)
Optimistic ( $t_0$ )	4
Pessimistic ( $t_P$ )	7
Most likely ( $t_M$ )	5

Using a beta distribution, how many hours in the weighted average activity time?

- A. 4.66
- B. 5.16
- C. 6.16
- D. 5.33

**Answer: A (LEAVE A REPLY)**

**NEW QUESTION: 515**

What are the four parts of the communications model?

- A. Communicator, Message, Receiver, Decoder
- B. Sending, Receiving, Decoding, and Comprehending

- C. Sender, Message, Medium, Receiver
- D. Communicating, Transmitting, Receiving, Comprehending

**Answer: C ([LEAVE A REPLY](#))**

**NEW QUESTION: 516**

You are in the process of developing an approximation of the costs of resources needed to complete each schedule activity. Which of the following is the LEAST helpful input?

- A. WBS, WBS dictionary
- B. Activity cost estimates, activity cost estimate supporting details
- C. Cost estimation policies/ templates, historical information, project team knowledge
- D. Schedule management plan, staffing management plan, risk register
- E. Market place conditions, commercial databases

**Answer: B ([LEAVE A REPLY](#))**

**NEW QUESTION: 517**

During project implementation, a project manager discovers that the quality of a deliverable does not meet the acceptance criteria. What should the project manager do next?

- A. Add it to the issue log and determine corrective actions.
- B. Review project performance indexes with the stakeholders.
- C. Report the nonconformance to the stakeholders.
- D. Perform a root cause analysis on the nonconformance.

**Answer: D ([LEAVE A REPLY](#))**

**NEW QUESTION: 518**

You must consider direct costs, indirect costs, overhead costs, and general and administrative costs during cost estimating. Which of the following is NOT an example of a direct cost?

- A. Salary of the project manager
- B. Subcontractor expenses
- C. Materials used by the project
- D. Electricity

**Answer: D ([LEAVE A REPLY](#))**

Section: Mix Questions

Explanation:

Direct costs are incurred for the exclusive benefit of a project (for example, salary of the project manager, materials used by the project, and subcontractor expenses). Indirect costs, also called overhead costs, are allocated to a project by its performing organization as a cost of doing business. These costs cannot be traced to a specific project and are accumulated and allocated equitably over multiple projects (for example, security guards, fringe benefits, and electricity).

**NEW QUESTION: 519**

A vendor who historically has not had quality issues, is delivering low-quality parts. The project manager is concerned that this will cause a delay due to rework.

What tool or technique should the project manager use to address this?

- A. Performance reporting
- B. Procurement control system
- C. Performance reviews
- D. Contract change control system

**Answer: B (LEAVE A REPLY)**

Section: Monitoring and Controlling

**NEW QUESTION: 520**

A project manager is leading a project in which key performance Indicators (KPIs) are measured through earned value management (EVM). Match each measurement on the left with the correct category on the right.

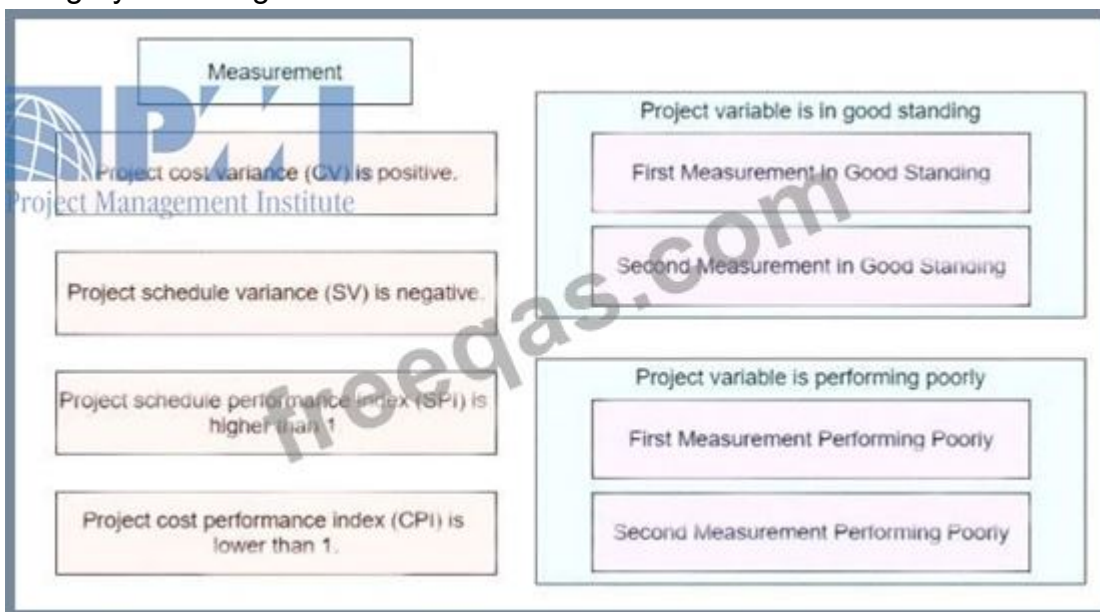

**Answer:**

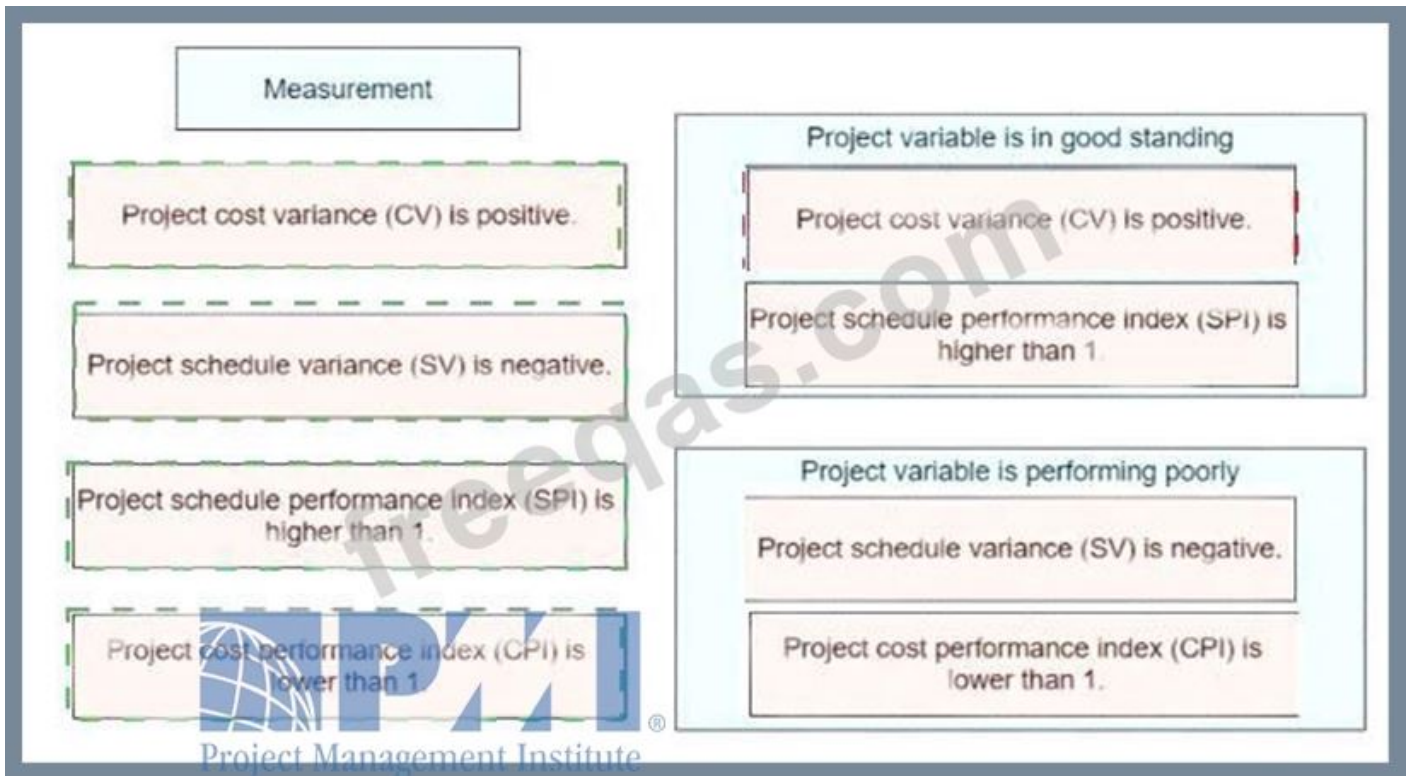

Explanation

Diagram Description automatically generated

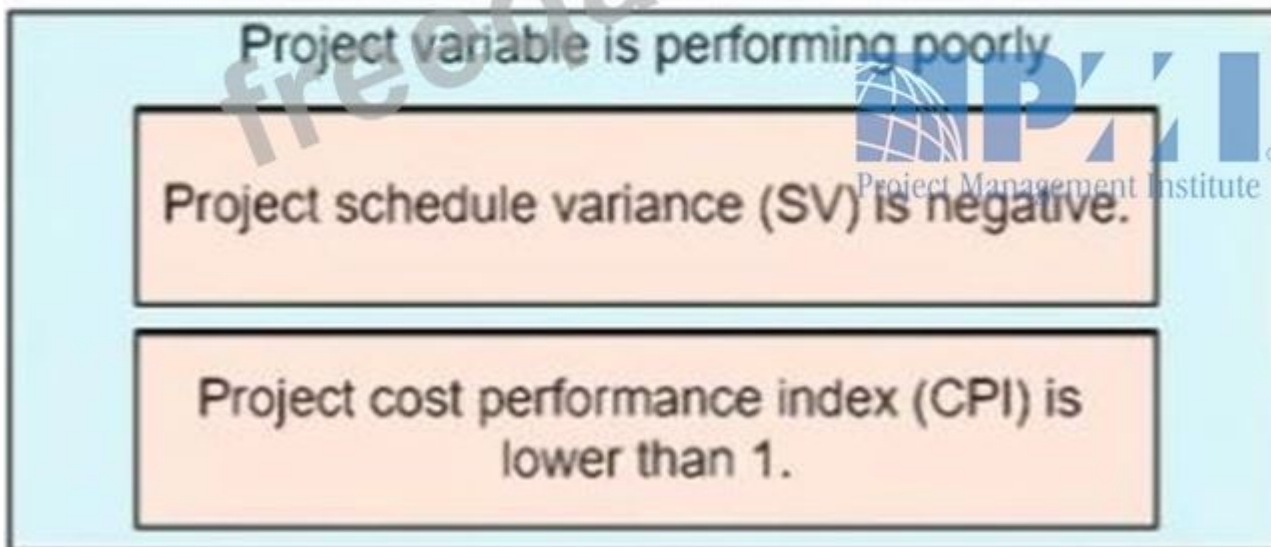
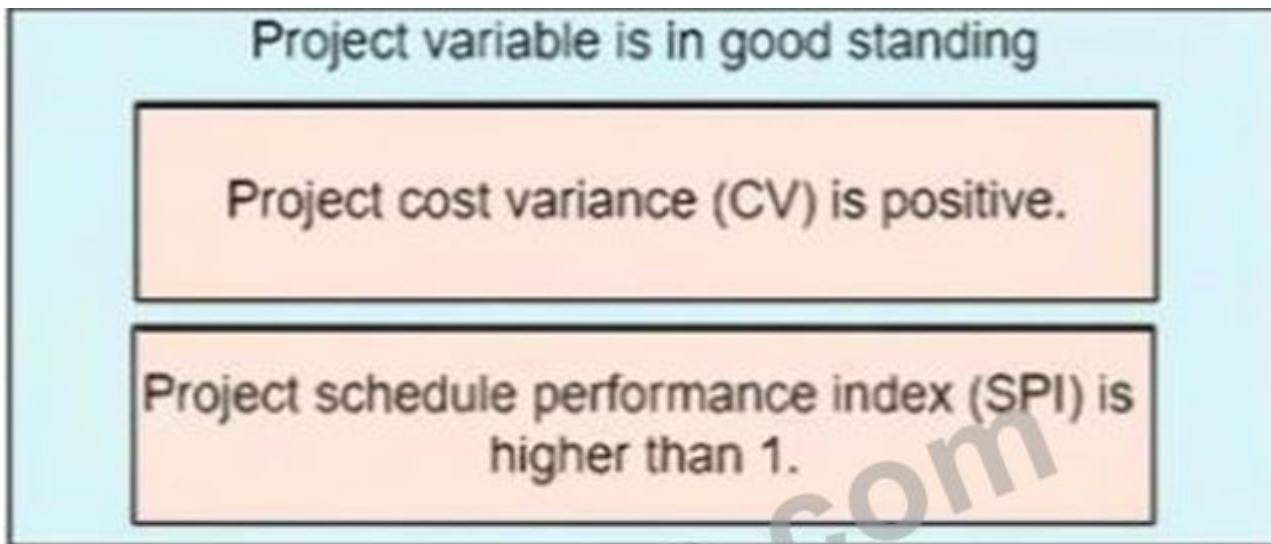

**NEW QUESTION: 521**

In which of the following methods of resolving conflict will the conflict typically reappear again in another form?

- A. Smoothing
- B. Compromising
- C. Collaborating
- D. Confronting

**Answer: ([SHOW ANSWER](#))**

Explanation/Reference:

Explanation:

Smoothing emphasizes areas of agreement while avoiding points of disagreement. It tends to keep peace only in the short term.

**NEW QUESTION: 522**

Investment in project development prevention is most often borne by the

- A. Project manager
- B. Product user
- C. Project team
- D. Performing organization

**Answer: D** ([LEAVE A REPLY](#))

**NEW QUESTION: 523**

What are seven consecutive data points on either side of the mean called?

- A. Too tight of control limits
- B. A violation of the Seven Run Rule
- C. Too loose of specification limits
- D. Acceptable measurements

**Answer: B** ([LEAVE A REPLY](#))

Section: Mix Questions

**NEW QUESTION: 524**

Inputs to scope definition include

- A. Scope statements, scope statement updates, other planning outputs, historical information
- B. Scope statements, scope measurement plan, other planning outputs, historical information
- C. Scope requests, constraints, assumptions, other planning outputs, historical information
- D. Scope statements, constraints, assumptions, other planning outputs, historical information

**Answer: D** ([LEAVE A REPLY](#))

**NEW QUESTION: 525**

A developer who has almost completed a required product feature for a prototype leaves the company in the middle of an iteration. What should the project manager do?

- A. Engage with stakeholders directly to review the iteration process.
- B. Go to management and ask to hire a new external developer.
- C. Determine whether other cross-functional team members are able to take over the work.
- D. Review the backlog to reschedule the deliverable for a later iteration.

**Answer: C** ([LEAVE A REPLY](#))

**NEW QUESTION: 526**

A Project Manager has been assigned to manage a project to develop a reduced price desktop computer for a company that does not have this expertise. The project is three weeks behind schedule and under budget. After calculating the estimate at completion (EAC), the Project Manager finds that project will be \$34,589 under budget, but is expected to take four weeks longer than expected. What should the Project Manager do?

- A. Report the current baseline project status and budget to the customer
- B. Report the project status and budget to the customer

- C. Implement Gold Plating to make up for the difference
- D. Bill for customer the total approved contracted amount

**Answer: B (LEAVE A REPLY)**

**Valid PMP Dumps** shared by PrepPdf.com for Helping Passing PMP Exam! PrepPdf.com now offer the **newest PMP exam dumps**, the PrepPdf.com PMP exam **questions have been updated** and **answers have been corrected** get the **newest** PrepPdf.com PMP dumps with Test Engine here: <https://www.preppdf.com/PMI/PMP-prepaway-exam-dumps.html> (2045 Q&As Dumps, **40%OFF Special Discount: Exam-Tests**)

**NEW QUESTION: 527**

Before authorizing resource assignments, a company's project management office (PMO) requires that the project manager present the approved project charter. However, the project sponsor is on vacation for the next three weeks. Stakeholders want the project to start as soon as possible. What should the project manager do?

- A. Obtain authorization from the steering committee.
- B. Hold the project until the sponsor approves the project charter.
- C. Find resources that can informally support the project to avoid delays.
- D. Review the main project milestones to identify potential task compression to avoid delays.

**Answer: A (LEAVE A REPLY)**

**NEW QUESTION: 528**

A project selection committee is shortlisting projects for the coming year. Which selection criteria should the project manager recommend?

- A. Projects with the least associated risks
- B. Projects that maximize the business value
- C. Projects with the least duration
- D. Projects with maximum revenue generation

**Answer: C (LEAVE A REPLY)**

**NEW QUESTION: 529**

The project Network Diagram is an input to what process?

- A. Schedule Development
- B. Activity Duration Estimating
- C. Schedule Control
- D. Activity Sequencing

**Answer: (SHOW ANSWER)**

**NEW QUESTION: 530**

As a project manager of a construction project, the project is currently in the execution phase. During a project update meeting for the key stakeholders, if the project sponsor informed you that the project no longer has any business value, what should you do next?

- A. Review the business case.
- B. Request the project sponsor to provide more details.
- C. Immediately terminate the project, since the project no longer makes any business value.
- D. Request the project customer to intervene.

**Answer:** ([SHOW ANSWER](#))

#### **NEW QUESTION: 531**

A watch list of low priority risks is documented in the \_\_\_\_\_

- A. Work performance information
- B. Risk register
- C. Fallback plans
- D. Risk response plan

**Answer:** ([SHOW ANSWER](#))

Section: Mix Questions

Explanation:

The monitor and control risks process includes keeping track of those risks on the watch list. Low-priority risks are inputs to the monitor and control risks process and are documented in the risk register. Other inputs that are part of the risk register include identified risks and risk owners, agreed-upon risk responses, control actions to assess the effectiveness of response plans, specific implementation actions, symptoms and warning signs of risk, residual and secondary risks, and the time and cost contingency reserves.

#### **NEW QUESTION: 532**

A project manager is leading a multiyear project that involves internal and external stakeholders. As the project manager begins to gather requirements, additional business stakeholders express interest in being involved.

Which three actions should the project manager take to ensure proper stakeholder involvement?

(Choose three)

- A. Prioritize stakeholders based on the project phase and need.
- B. Include all stakeholders in the stakeholder engagement plan and provide the same level of communication.
- C. Develop a stakeholder impact influence matrix to determine the level of engagement
- D. Perform a stakeholder assessment to align with the project objectives.
- E. Classify and rank stakeholders based on their positions in the organization.

**Answer:** B,C,D ([LEAVE A REPLY](#))

#### **NEW QUESTION: 533**

A project stakeholder requested a scope enhancement that was not approved due to budget constraints. Two months later, the project manager learns that the budget has enough flexibility to enhance scope.

To resubmit the identical request, to what document should the project manager refer?

- A. Change log
- B. Issue log
- C. Risk register
- D. Stakeholder register

**Answer: A ([LEAVE A REPLY](#))**

Section: Executing

#### **NEW QUESTION: 534**

Financial compensation is the primary motivational tool for which of the following management theories of programs.

- A. theory X management.
- B. Zero-defects program.
- C. Quality control circles.
- D. Zero-defects program and theory Y management.
- E. theory Y management.

**Answer: A ([LEAVE A REPLY](#))**

#### **NEW QUESTION: 535**

The project charter for a new project is authorized, and the company's executives appoint a project manager. What should the project manager do first?

- A. Appoint and assign project team members.
- B. Identify and report the high-level risks to the executives.
- C. Define and prepare the project management plan.
- D. Define the project scope.

**Answer: ([SHOW ANSWER](#))**

#### **NEW QUESTION: 536**

All the following are examples of project document updates from the manage project team process EXCEPT \_\_\_\_\_

- A. Issue log
- B. Roles description
- C. Project staff assignments
- D. Personnel skills

**Answer: D ([LEAVE A REPLY](#))**

Section: Mix Questions

Explanation:

Personnel skill updates are an example of an enterprise environmental factor that may require updates as a result of the manage project team process along with inputs to the organizational performance appraisals.

**NEW QUESTION: 537**

Contingency planning should include all but which of the following?

- A. The development of a contingency allowance determined by combining (layering) various estimate segments to form larger estimate segments.
- B. the development of schedule alternatives and work-around
- C. Both 1) The development of a contingency allowance determined by combining (layering) various estimate segments to form larger estimate segments, and 2) the management of a contingency budget
- D. the management of a contingency budget
- E. an assessment of project shut-down liabilities.

**Answer: A ([LEAVE A REPLY](#))**

**NEW QUESTION: 538**

Six weeks into project execution, a key stakeholder requests a change The stakeholder states that this request should be treated as high priority.

What should the project manager do next?

- A. Seek expert advice to better understand and evaluate the importance of the change.
- B. Direct the team to implement the change
- C. Check the scope statement to determine if the change is within scope
- D. Issue a change request to the change control board (CCB): and communicate its priority

**Answer: ([SHOW ANSWER](#))**

**NEW QUESTION: 539**

Which of the following is LEAST likely to improve the accuracy of cost estimates produced through parametric cost estimating technique?

- A. When historical information used to develop the model is accurate
- B. When parameters used in the model are quantifiable
- C. When model is scalable
- D. When cost estimates of individual work packages are detailed and accurate

**Answer: ([SHOW ANSWER](#))**

**NEW QUESTION: 540**

Which tool or technique of Plan Quality involves comparing actual or planned practices to those of other projects to generate ideas for improvement and provide a basis by which to measure performance?

- A. Performance measurement analysis
- B. Quality audits

C. Benchmarking

D. Histogram

**Answer: C (LEAVE A REPLY)**

**NEW QUESTION: 541**

The Project Manager is creating an estimate for building a company WAN (wide area network.) As the Project Manager, you have undertaken the make-or-buy decision and determined that the WAN implementation should be outsourced because your company does not have the expertise. After receiving all the vendor proposals, you find that two of the proposals specify cost-plus-fixed-fee, two other of the vendors specify fixed-price, another two specify cost-plus-incentive-fee, and the last two specify time and material. Which of the proposals would present the least probability of loss for the company?

A. Proposals that use fixed-price

B. Proposals that use cost-plus-fixed-fee

C. Proposals that use time and material

D. Proposals that use cost-plus-incentive-fee

**Answer: (SHOW ANSWER)**

Section: Mix Questions

**Valid PMP Dumps** shared by PrepPdf.com for Helping Passing PMP Exam! PrepPdf.com now offer the **newest PMP exam dumps**, the PrepPdf.com PMP exam **questions have been updated** and **answers have been corrected** get the **newest** PrepPdf.com PMP dumps with Test Engine here: <https://www.preppdf.com/PMI/PMP-prepaway-exam-dumps.html> (2045 Q&As Dumps, **40%OFF Special Discount: Exam-Tests**)

**NEW QUESTION: 542**

Which process involves determining, documenting, and managing stakeholders' needs and requirements to meet project objectives?

A. Collect Requirements

B. Plan Scope Management

C. Define Scope

D. Define Activities

**Answer: A (LEAVE A REPLY)**

**NEW QUESTION: 543**

Deflection involves the transfer of risk by:

A. Contracting out to another party

B. Developing schedule alternative.

C. None of the other alternatives apply .

- D. Disaster planning and responses.
- E. Establishing functions under the project manager to handle risk events.

**Answer: A ([LEAVE A REPLY](#))**

**NEW QUESTION: 544**

Managing procurement relationships and monitoring contract performance are part of which process?

- A. Conduct Procurements
- B. Plan Procurements
- C. Administer Procurements
- D. Close Procurements

**Answer: C ([LEAVE A REPLY](#))**

Section: Executing

**NEW QUESTION: 545**

A project manager has recently taken over a project and notices that a client team member often halts progress due to a lack of understanding of some project elements.

The former project manager gave the new project manager a complete list of people to communicate with, and this client team member is not on it.

What should the project manager do?

- A. Update the communications matrix to ensure that client team member is included.
- B. Submit a change request to cover extra hours associated with project meetings.
- C. Increase the project meeting frequency and duration to allow for the extra work required.
- D. Speak with the client team member about the continuous delays during project meetings.

**Answer: ([SHOW ANSWER](#))**

**NEW QUESTION: 546**

To ensure that every part of a project is not reworked, a project manager establishes a quality control task for each deliverable. However, the team believes that the additional review tasks are a waste of time. While they initially follow the quality control schedule, they stop shortly thereafter. Five weeks after the release of one of the deliverables, the client informs the project manager that there are some flaws that render the deliverable useless. The client wants the problem corrected at no additional cost, and sets a deadline of three days.

What should the project manager do first?

- A. Evaluate the quality issue with the team.
- B. Immediately correct the issue with the team.
- C. Escalate the situation to their manager.
- D. Engage the team in the importance of quality control reports to avoid rework.

**Answer: D ([LEAVE A REPLY](#))**

Section: Monitoring and Controlling

**NEW QUESTION: 547**

According to Maslow's hierarchy of needs in which does the need for acceptance occurs?

- A. Social needs
- B. Safety and security
- C. Self-actualization
- D. Esteem

**Answer:** ([SHOW ANSWER](#))

**NEW QUESTION: 548**

On the WBS, the first level of decomposition may be displayed by using all the following EXCEPT \_\_\_\_\_

- A. Phases of the project life cycle
- B. Subcomponents
- C. Major deliverables
- D. Project organizational units

**Answer:** D ([LEAVE A REPLY](#))

Explanation/Reference:

Explanation:

The WBS includes all work needed to be done to complete the project. The organizational breakdown structure (OBS) includes the organizational units responsible for completing the work.

**NEW QUESTION: 549**

What is the difference between the critical path and the critical chain?

- A. Scope changes
- B. Resource limitations
- C. Risk analysis
- D. Quality audits

**Answer:** B ([LEAVE A REPLY](#))

Section: Monitoring and Controlling

**NEW QUESTION: 550**

During your assignment as project manager you add a new member to your project team. This new team member was recently hired from a competitor and offers to share a substantial amount of proprietary information from his previous company. This information could put you and your team in a very strong position for future business. You are aware of a non- compete clause in the new hire's condition of employment. You should:

- A. Ignore the offer to share and move forward with the project
- B. Review the information and only accept only what may have a direct impact on the project's financial status.
- C. Accept the information and agree to keep it confidential between you and the new hire.
- D. Review the condition of employment with the new hire and advise her to reconsider the offer.

**Answer: D ([LEAVE A REPLY](#))**

**NEW QUESTION: 551**

The project is progressing. As the company starts to release the product of the project to market, the consumer isn't buying it as the company had projected. This appears to be because the company has released a lot of products before that had an excessive number of defects. Who was ultimately responsible for these products being released with the defects?

- A. Functional management
- B. Project Manager
- C. The developer
- D. Senior management

**Answer: D ([LEAVE A REPLY](#))**

Section: Mix Questions

**NEW QUESTION: 552**

A stakeholder teams from a project team member that the project has fallen behind in advance of the status report The stakeholder is agitated when communicating this to the project manager. What should the project manager do?

- A. Establish the stakeholder's level of influence, and, if it is high, engage the stakeholder to discuss the schedule delay
- B. Email relevant stakeholders explaining that the matter will be discussed at the next meeting
- C. Review the risk management plan with the project team
- D. Ask the project sponsor to arrange a meeting with all stakeholders to address concerns

**Answer: ([SHOW ANSWER](#))**

**NEW QUESTION: 553**

Project deliverables are the outputs that include the product, service, or result of the project as well as ancillary results. These ancillary results should be in the\_\_\_\_\_

- A. Requirements management plan
- B. Scope management plan
- C. Project scope statement
- D. Project acceptance criteria

**Answer: ([SHOW ANSWER](#))**

Explanation/Reference:

Explanation:

The project scope statement describes in detail the deliverables and what work must be done to prepare them. Ancillary results are also considered deliverables and are included in the project scope statement.

They include items such as project management reports and documentation. Deliverables in the project scope statement may be described at a summary level or in a detailed way.

**NEW QUESTION: 554**

You are responsible for the communication controls for the Genesis series of satellites. Your current assignment is:

- A. Project management
- B. Program management
- C. Facility management
- D. Functional management

**Answer: ([SHOW ANSWER](#))**

**NEW QUESTION: 555**

In a multinational project, stakeholders are in different time zones. The project manager has regular project update meetings with the stakeholders. However, a group of stakeholders who has never attended project update meetings is complaining to the project sponsor that they know very little about the project.

What should the project manager do?

- A. Discuss the issue with all stakeholders and work on a communications management plan to meet all stakeholder requirements.
- B. Record the regular project update meeting and share it with all stakeholders after the meeting is completed.
- C. Change the meeting time to the working time zones of the stakeholders who are complaining.
- D. Ensure that the stakeholders who are complaining are present for the next project update meetings.

**Answer: ([SHOW ANSWER](#))**

**NEW QUESTION: 556**

On a precedence diagram, the arrow between two boxes is called:

- A. The critical path.
- B. None of the other alternatives apply.
- C. A constraint.
- D. An event.
- E. An activity.

**Answer: C ([LEAVE A REPLY](#))**

**Valid PMP Dumps** shared by PrepPdf.com for Helping Passing PMP Exam! PrepPdf.com now offer the **newest PMP exam dumps**, the PrepPdf.com PMP exam **questions have been updated** and **answers have been corrected** get the **newest** PrepPdf.com PMP dumps with Test Engine here: <https://www.preppdf.com/PMI/PMP-prepaway-exam-dumps.html> (2045 Q&As Dumps, **40%OFF Special Discount: Exam-Tests**)

**NEW QUESTION: 557**

A multinational project includes stakeholders from various locations and cultures. During the final acceptance stage, a new stakeholder is added who refuses to provide final approval.

What should the project manager do?

- A. Review the project acceptance criteria with the new stakeholder.
- B. Escalate the issue with the sponsor.
- C. Issue a formal change request.
- D. Contact the previous stakeholder for a resolution.

**Answer:** ([SHOW ANSWER](#))

**NEW QUESTION: 558**

The determination of conformance with scope requirements is called \_\_\_\_\_?

- A. Quality Control.
- B. Quality Assurance.
- C. Quality Planning.
- D. Quality Management.

**Answer:** ([SHOW ANSWER](#))

**NEW QUESTION: 559**

A project manager is initiating a highly controversial project with numerous stakeholders. Several of these stakeholders fail to support the project.

What should the project manager use to manage stakeholder expectations?

- A. Risk register
- B. Stakeholder engagement plan
- C. Stakeholder register
- D. Responsibility assignment matrix (RAM)

**Answer:** ([SHOW ANSWER](#))

**NEW QUESTION: 560**

Which of the following is not an input into Project Plan Development:

- A. Project Planning Methodology
- B. Organizational policies
- C. Constraints and assumptions
- D. Historical information

**Answer:** A ([LEAVE A REPLY](#))

**NEW QUESTION: 561**

Management reserve is generally intended to be used to:

- A. implement additional unbudgeted scope
- B. cover major unforeseen catastrophes
- C. compensate for inaccurate estimates

- D. All of the other alternatives apply.
- E. cover unforeseen problems in the project

**Answer:** ([SHOW ANSWER](#))

**NEW QUESTION: 562**

In an agile team, some of the team members are coming forward to ask for more autonomy on the project. What should the project manager do in this situation?

- A. Discourage this request, as it is for the management team.
- B. Encourage the team members to make decisions.
- C. Discourage them as conflicts may be created.
- D. Encourage the team lead to make decisions.

**Answer:** B ([LEAVE A REPLY](#))

**NEW QUESTION: 563**

During project execution, a project manager learns that a team member's functional manager believes. They should not execute a certain task. What document should the project manager review to resolve this?

- A. Responsibility assignment matrix (RAM)
- B. Organizational chart
- C. Work breakdown structure (WBS)
- D. Resource management plan

**Answer:** A ([LEAVE A REPLY](#))

**NEW QUESTION: 564**

The specifications for a particular part are "10 +/-0.015". The associated process produces parts with a mean of 10 and a standard deviation of 0.002. The process capability index is:

- A. 0.0002
- B. 1.0
- C. 2.5
- D. 7.5

**Answer:** C ([LEAVE A REPLY](#))

Section: (none)

Explanation/Reference:

Process Capability Index is the expected fraction of non-conforming units and is given by:

$PCI = (\text{Upper Spec Limit} - \text{Lower Spec Limit}) / (6 \text{ Sigma}) = (10.015 - 9.985) / (6 * 0.002) = 0.03 / 0.012 = 2.5$ , so answer is c.

**NEW QUESTION: 565**

Which of the following reduces the probability of potential consequences of project risk events?

- A. Corrective action
- B. Preventive action

- C. Defect repair
- D. Risk management

**Answer: B ([LEAVE A REPLY](#))**

**NEW QUESTION: 566**

At the beginning of a project you are asked for an order of magnitude budget. What type of budget estimate are you likely to use?

- A. Parametric modeling
- B. Bottom-up
- C. Detailed
- D. Analogous

**Answer: D ([LEAVE A REPLY](#))**

**NEW QUESTION: 567**

The delphi Method is best suited for:

- A. Cost Control
- B. Team discussions
- C. Decision-making
- D. Overhead rate estimating

**Answer: ([SHOW ANSWER](#))**

**NEW QUESTION: 568**

Project life cycles provide a better means of measurement of progress and control. The four phases of a project are conceptual development, \_\_\_\_\_, \_\_\_\_\_, and \_\_\_\_\_.

- A. Implementation, termination, post-audit review
- B. Development, implementation, termination
- C. Preliminary planning, detail planning, closeout
- D. Implementation, reporting, termination
- E. Execution, reporting, finishing

**Answer: B ([LEAVE A REPLY](#))**

**NEW QUESTION: 569**

An effective Project Manager does not share project \_\_\_\_\_ with the team members.

- A. status
- B. accountability
- C. responsibility
- D. solution to problems
- E. Vision

**Answer: B ([LEAVE A REPLY](#))**

**NEW QUESTION: 570**

In the PDM, common constraints include:

- A. Finish-to-start
- B. Finish-to-start and Finish-to-finish
- C. Start-to-start, Finish-to-start and Finish-to-finish.
- D. Finish-to-finish
- E. Start-to-start

**Answer: C** ([LEAVE A REPLY](#))

**NEW QUESTION: 571**

Which statement relating to Scope Verification and Quality control is correct?

- A. Scope Verification is concerned with correctness of the work results while quality control is primarily concerned with acceptance of the work results.
- B. Scope Verification is concerned with acceptance of the work results while quality control is primarily concerned with correctness of the work results.
- C. Scope Verification and Quality Control are performed sequentially and supplement each other
- D. Both are similar

**Answer: B** ([LEAVE A REPLY](#))

**Valid PMP Dumps** shared by PrepPdf.com for Helping Passing PMP Exam! PrepPdf.com now offer the **newest PMP exam dumps**, the PrepPdf.com PMP exam **questions have been updated** and **answers have been corrected** get the **newest** PrepPdf.com PMP dumps with Test Engine here: <https://www.preppdf.com/PMI/PMP-prepaway-exam-dumps.html> (2045 Q&As Dumps, **40%OFF Special Discount: Exam-Tests**)

**NEW QUESTION: 572**

A project manager is working on a five-year US\$200 million project Procedural document management is listed as the sponsor's main requirement prioritized even above the design itself After identifying key deliverables in the form of documented designs, the project manager contracts a document controller In this case what plan is the key component of the project manager's risk management plan\*?

- A. Quality management
- B. Cost management
- C. Requirements management
- D. Resource management

**Answer: C** ([LEAVE A REPLY](#))

**NEW QUESTION: 573**

A project manager realizes that the team members are new to the hybrid approach and do not value standup meetings. Team members often arrive late. Digress into solutioning. or skip the meetings altogether.

How should the project manager improve this situation with the project team?

- A. Ask the product owner to remove team members who do not comply with standup meeting rules.
- B. Include a daily brainstorming session In the standup meetings to resolve pending Issues.
- C. Engage the project team In implementing and Improving key aspects of the standup meetings.
- D. Send a daily retrospective report to all team members instead of holding standup meetings.

**Answer: B ([LEAVE A REPLY](#))**

#### **NEW QUESTION: 574**

A project manager receives an email from a vendor that a key deliverable will be delayed by a month. What should the project manager do first?

- A. Call the vendor to obtain a justification for the delay
- B. Update management and obtain their advice.
- C. Assess the impact of the delay on the project plan
- D. Meet with the team to identify ways to absorb this delay.

**Answer: ([SHOW ANSWER](#))**

#### **NEW QUESTION: 575**

The Create WBS process is in which of the following Project Management Process Groups?

- A. Planning
- B. Monitoring and Controlling
- C. Executing
- D. Initiating

**Answer: A ([LEAVE A REPLY](#))**

Section: Planning

#### **NEW QUESTION: 576**

A new privacy law will go into effect at the beginning of the next calendar year. The project manager realizes the project needs to be compliant with the new law. What should the project manager do next?

- A. Inform the product owner that the project will continue as planned.
- B. Inform the project steering committee of this constraint.
- C. Inform the project team and create a spike for the next Iteration.
- D. Inform the legal department that the project scope will be updated.

**Answer: ([SHOW ANSWER](#))**

#### **NEW QUESTION: 577**

The major project scope management processes include:

- A. Scope statement
- B. Program evaluation
- C. Initiation
- D. Change order control

**Answer: C ([LEAVE A REPLY](#))**

Initiation included in major project scope management processes

**NEW QUESTION: 578**

An element of the project scope statement is:

- A. Acceptance criteria.
- B. High-level risks.
- C. A stakeholder list.
- D. A summary budget,

**Answer: A ([LEAVE A REPLY](#))**

**NEW QUESTION: 579**

The control chart is a tool used primarily to help\_\_\_\_\_

- A. Monitor process variation over time
- B. Measure the degree of conformance
- C. Determine whether results conform
- D. Determine whether results conform to requirements

**Answer: A ([LEAVE A REPLY](#))**

Explanation/Reference:

Explanation:

Used to monitor process variation and to detect and correct changes in process performance, the control chart helps people understand and control their processes and work. It enables the project manager, along with appropriate stakeholders, to identify points where corrective action can be taken to prevent unnatural performance.

**NEW QUESTION: 580**

In a team meeting, two of the managers start a discussion that escalates into an argument. In order to restore peace to the meeting you point out the part of the conflict that they both agree to and using friendly tones try to defuse the current situation. This is an example of what type of conflict management?

- A. Smoothing
- B. Problem solving
- C. Withdrawal
- D. Compromising

**Answer: A ([LEAVE A REPLY](#))**

**NEW QUESTION: 581**

A project manager is leading an integration project for a retail company. The project demands a lot of time from the stakeholders to make important business decisions. The project is critical and must be completed on time and within budget.

What should the project manager do to ensure that key stakeholders are available for this project?

- A. Work with the available stakeholders to make business decisions and keep all unavailable stakeholders informed.
- B. Share the project schedule, milestones, and meeting agendas with the stakeholders ahead of time.
- C. Add time reserve in the project schedule to allow extra time for the stakeholders to make decisions.
- D. Schedule meetings with all of the stakeholders to make business decisions when needed.

**Answer: B (LEAVE A REPLY)**

#### **NEW QUESTION: 582**

As the project progresses, which of the following is routinely collected from the project activities?

- A. Change requests
- B. Work performance information
- C. Configuration verification and audit
- D. Communication management activities

**Answer: B (LEAVE A REPLY)**

#### **NEW QUESTION: 583**

Which of the following statements are FALSE regarding Monte Carlo analysis?

- A. Monte Carlo is simulation technique that can help quantify risks associated with the project
- B. Monte Carlo analysis can be used during the Schedule Development and Quantitative Risk Analysis process
- C. Monte Carlo analysis used expected value (EV) calculations as one of its inputs
- D. Monte Carlo is used to determine potential project outcomes by simulating the project under different scenarios

**Answer: C (LEAVE A REPLY)**

#### **NEW QUESTION: 584**

A project team is facing challenges understanding how to deliver a project's scope.

A senior subject matter expert (SME) from the organization's global office is in town for 1 week.

What should the project manager do to benefit from the SME's presence?

- A. Ask the SME to review the scope for alignment with the project charter.
- B. Organize a mentoring session with the team and the SME.
- C. Meet with the SME to discuss the current challenges the team is facing.
- D. Review the project scope statement with the SME.

**Answer: B (LEAVE A REPLY)**

**NEW QUESTION: 585**

Which of the following options would you take to determine what impact a change had?

- A. Reviewing the earned value.
- B. Performance measurement.
- C. Re-evaluating the work breakdown structure.
- D. Assessing the communication policy.

**Answer: B (LEAVE A REPLY)**

**NEW QUESTION: 586**

The Project Management Knowledge Areas \_\_\_\_\_ .

- A. include Planning, Executing, and Monitoring and Controlling processes because these three processes are commonly interlinked
- B. consist of nine areas that bring together processes that have things in common
- C. consist of five processes that bring together phases of projects that have things in common
- D. include Initiation, Planning, Executing, Monitoring and Controlling, and Closing

**Answer: B (LEAVE A REPLY)**

The project management Knowledge Areas bring processes together that have commonalities. For example, the Project Quality Management Knowledge Area includes the Quality Planning, Perform Quality Assurance, and Perform Quality Control processes.

**Valid PMP Dumps** shared by PrepPdf.com for Helping Passing PMP Exam! PrepPdf.com now offer the **newest PMP exam dumps**, the PrepPdf.com PMP exam **questions have been updated** and **answers have been corrected** get the **newest** PrepPdf.com PMP dumps with Test Engine here: <https://www.preppdf.com/PMI/PMP-prepaway-exam-dumps.html> (2045 Q&As Dumps, **40%OFF Special Discount: Exam-Tests**)

**NEW QUESTION: 587**

A project manager presents the project scope and deliverables to stakeholders. Two stakeholders disagree about the project scope.

What should the project manager do?

- A. Create a project charter to obtain strategic alignment between the two stakeholders.
- B. Update the stakeholder engagement plan to document the concerns.
- C. Brainstorm with the stakeholders to clarify requirements.
- D. Accommodate the project scope requirements of the more senior stakeholder.

**Answer: C (LEAVE A REPLY)**

Section: Initiation

**NEW QUESTION: 588**

An IT department's deliverable is two weeks late. If the deliverable is not completed by the end of the week, the project will be placed on hold. Within the last two weeks, the project manager communicated the issue to the IT department, spoke with the IT project manager, and elevated the risk level in the risk register.

To support the work, what should the project manager do next?

- A. Analyze stakeholder communications requirements.
- B. Validate the communications management plan.
- C. Apply the escalation process defined in the communications management plan.
- D. Communicate to the project stakeholders that the project will be delayed.

**Answer: C (LEAVE A REPLY)**

Section: Executing

**NEW QUESTION: 589**

According to a new product development process, the marketing department will begin adding business and user requirements directly into agile project documents. Drag the product information on the left to the correct documents on the right

Product Information	Documents
Competitive differentiators a product can provide	Definition of Done (DoD)
Description of how credit card data privacy is handled when a user makes a purchase	Product Backlog
Confirmation that a test successfully showed that a user mistake is well handled	Product Vision

**Answer:**

Product Information

Documents

Competitive differentiators a product can provide

Confirmation that a test successfully showed that a user mistake is well handled

Description of how credit card data privacy is handled when a user makes a purchase

Description of how credit card data privacy is handled when a user makes a purchase

Confirmation that a test successfully showed that a user mistake is well handled

Competitive differentiators a product can provide



**NEW QUESTION: 590**

Which organization is same as Functional organization?

- A. Weak Matrix organization
- B. Balanced Matrix organization
- C. Strong Matrix
- D. Projectized organization

**Answer: A (LEAVE A REPLY)**

Weak Matrix: Power reset with Functional Manager and Functional organization:

Project Manager has least power and all management is taken care by functional manager like marketing engineer, sales engineer etc.

**NEW QUESTION: 591**

2 people are arguing about what needs to be done to complete a task. If the project manager wants to know what is going on, she should pay MOST attention on:

- A. What is said
- B. What is being discussed according to those arguing
- C. Physical mannerisms
- D. The pitch and tone of the voice.

**Answer: C (LEAVE A REPLY)**

[#1] I think A/B should be the way to know what is going on. Explanation is just about 55% of communication is non-verbal. This cannot convince me since I think the key point here is she needs to know the content of the arguing. How can C help on this? [#2] If the question asked what should she pay attention to, all four choices would be correct. The question is asking what is the MOST important, and according to Rita, the non-verbal is the most important, i.e. 55% of communication, therefore that ranks #1. The PM must still pay attention to what is said, etc. She is not excluding the other information.

#### **NEW QUESTION: 592**

A project manager has been receiving enhancements to a product that will be launched in five months. What should the project manager do next to ensure that these enhancements are included in the product release?

- A. Revise the risk management plan.
- B. Implement the Control Quality process.
- C. Update the project scope statement.
- D. Begin the Perform Integrated Change Control process.

**Answer: (SHOW ANSWER)**

#### **NEW QUESTION: 593**

The most appropriate project life cycle model for an environment with a high level of change and extensive stakeholder involvement in projects is:

- A. adaptive
- B. reflexive
- C. predictive
- D. iterative

**Answer: (SHOW ANSWER)**

Section: Executing

#### **NEW QUESTION: 594**

During project execution, a project manager identifies a major obstacle that is preventing progress. An escalation to the client's project manager has gone unanswered, and project progress is worsening each week.

What should the project manager do?

- A. Follow the escalation matrix in the project management plan, and escalate it to the next level
- B. Inform the supervisor of the Client's project manager
- C. Revise the communications management plan

D. Escalate the issue directly to the steering committee

**Answer: A ([LEAVE A REPLY](#))**

**NEW QUESTION: 595**

The \_\_\_\_\_ task relationship is defined by the activity duration:

- A. Finish-to-finish
- B. None of the above
- C. Start-to-finish
- D. Start-to-start

**Answer: ([SHOW ANSWER](#))**

**NEW QUESTION: 596**

While implementing your project, a team member brings to your notice, a risk that was not mentioned in the Risk Response Plan. In this case, you should:

- A. Accept the risk
- B. Perform Additional Risk Response Planning to control the risk
- C. Use project contingency
- D. Inform the project sponsor

**Answer: ([SHOW ANSWER](#))**

**NEW QUESTION: 597**

A company's senior manager is expected to supply dedicated resources for a project. However, the project manager has yet to receive the names of these resources. What document can the project manager share with the senior manager to enforce their authority to obtain resources?

- A. Project training plans
- B. Project charter
- C. Project schedule
- D. Project management plan

**Answer: D ([LEAVE A REPLY](#))**

**NEW QUESTION: 598**

You are in the process of establishing a total cost baseline for measuring project performance. All of the following are outputs of this process EXCEPT:

- A. Requested changes
- B. Project funding requirements
- C. Cost management plan updates
- D. Scope baseline
- E. Activity cost estimates

**Answer: ([SHOW ANSWER](#))**

**NEW QUESTION: 599**

Two project team members have a different understanding of the intent of a work package. What should the project manager do?

- A. Empower the team members to request clarification from the client.
- B. Conduct a brainstorming session with the team.
- C. Review the work breakdown structure (WBS) dictionary with the team members.
- D. Tell the team members to refer to the work authorization system.

**Answer: (SHOW ANSWER)**

Section: Executing

#### **NEW QUESTION: 600**

A tool or technique in Perform Quality Control that a project manager would use is:

- A. quality audits.
- B. inspection.
- C. benchmarking.
- D. process analysis.

**Answer: B (LEAVE A REPLY)**

#### **NEW QUESTION: 601**

Which of the Project Time Management processes analyzes activity sequencing, durations, resource requirements, and schedule constraints?

- A. Sequence Activities
- B. Develop Schedule
- C. ControlSchedule
- D. Estimate Activity Durations

**Answer: B (LEAVE A REPLY)**

**Valid PMP Dumps** shared by PrepPdf.com for Helping Passing PMP Exam! PrepPdf.com now offer the **newest PMP exam dumps**, the PrepPdf.com PMP exam **questions have been updated** and **answers have been corrected** get the **newest** PrepPdf.com PMP dumps with Test Engine here: <https://www.preppdf.com/PMI/PMP-prepaway-exam-dumps.html> (2045 Q&As Dumps, **40%OFF Special Discount: Exam-Tests**)

#### **NEW QUESTION: 602**

A key tool and technique used in define scope is \_\_\_\_\_

- A. Templates, forms, and standards
- B. Decomposition
- C. Expert judgment
- D. Project management methodology

**Answer: (SHOW ANSWER)**

Explanation/Reference:

Explanation: Expert judgment is used to analyze the information needed to develop a project scope statement. It is applied to any technical details.

**NEW QUESTION: 603**

Which of the following statements best describes the influence of stakeholders and the cost of changes as project time advances?

- A. The influence of the stakeholders increases, the cost of changes increases.
- B. The influence of the stakeholders decreases, the cost of changes increases.
- C. The influence of the stakeholders increases, the cost of changes decreases.
- D. The influence of the stakeholders decreases, the cost of changes decreases.

**Answer: B** ([LEAVE A REPLY](#))

Section: Initiation

**NEW QUESTION: 604**

You are the project manager of a village housing construction project. You are interviewing the village owners to determine their requirements, needs, and desires for the home construction.

What is this technique called?

- A. Quality
- B. Risk analysis
- C. Scope creation
- D. Stakeholder analysis

**Answer: D** ([LEAVE A REPLY](#))

**NEW QUESTION: 605**

Activity A is worth \$300, is 100% complete, and actually cost \$350. Activity B is worth \$100, is 95% complete, and actually cost \$85 so far. Activity C is worth \$200, is 75% complete, and has cost \$175 so far. The total budget is \$1500. What is the cost variance for the activities listed?

- A. \$0.84
- B. \$65.00
- C. -\$65.00
- D. -\$57.50

**Answer: C** ([LEAVE A REPLY](#))

Section: Mix Questions

**NEW QUESTION: 606**

A risk management plan is a subset of the project management plan and describes how risk management should be performed. All of the following should be included in the risk management plan EXCEPT:

- A. Budgeting, timing, risk categories
- B. None of the choices are correct

- C. Methodology, roles and responsibilities
- D. P-I matrix, tracking
- E. Stakeholder tolerance, reporting formats

**Answer: B ([LEAVE A REPLY](#))**

**NEW QUESTION: 607**

A project is being audited to ensure compliance with organizational policies. What process is being conducted

- A. Audit Schedule
- B. Control Quality
- C. Manage Quality
- D. Plan Quality Management

**Answer: C ([LEAVE A REPLY](#))**

**NEW QUESTION: 608**

Procurement audits review which of the following?

- A. The contract administration process from Solicitation Planning through Contract Closure
- B. The procurement process from Procurement Planning through Contract Administration
- C. The procurement process from Procurement Planning through Contract Closure
- D. The contract administration process from Solicitation Planning through Contract Administration

**Answer: ([SHOW ANSWER](#))**

According to the PMBOK Guide, the procurement audit examines the procurement process from Procurement Planning through Contract Administration.

**NEW QUESTION: 609**

You have been recently hired to be a project manager at a bio-tech company to develop a new drug to treat pancreatic cancer. The project requires significant coordination across multiple departments from R&D to manufacturing. You've attempted to gain the cooperation of the chief scientist within the R&D, however the Chief scientist is focused on completing her to-day tasks, and you do not have any control over her work assignment. What is the best way to describe her current organizational structure?

- A. Strong Matrix
- B. Projectized
- C. Balanced Matrix
- D. Functional

**Answer: D ([LEAVE A REPLY](#))**

**NEW QUESTION: 610**

Building a virtual team for a project will limit the usability of which of the following tools and techniques for Team Development:

- A. Working together on Co-Location

- B. Establishing Ground Rules
- C. Reward and Recognitions
- D. Team Building

**Answer: A ([LEAVE A REPLY](#))**

Virtual team for a project will limit the usability of Working together on Co-Location.

**NEW QUESTION: 611**

A project manager wants to establish a benchmark for comparing actual project performance with the project management plan. What process should the project manager complete to generate this model?

- A. Sequence Activities
- B. Create WBS
- C. Develop Project Charter
- D. Develop Schedule

**Answer: A ([LEAVE A REPLY](#))**

**NEW QUESTION: 612**

An input of the Plan Procurement Management process is:

- A. Make-or-buy decisions.
- B. Activity cost estimates.
- C. Seller proposals.
- D. Procurement documents.

**Answer: B ([LEAVE A REPLY](#))**

Section: Monitoring and Controlling

**NEW QUESTION: 613**

Market research shows that developing new features in a best-selling product will be vital to a company's future. A project manager identifies risks in this development, which could lead to losses for the company.

What should the project manager do next?

- A. Hire a specialist to develop the work.
- B. Plan the risk response.
- C. Request a meeting with the marketing department.
- D. Meet with the project team to monitor and control risk.

**Answer: B ([LEAVE A REPLY](#))**

Section: Planning

**NEW QUESTION: 614**

Impacts to other organizational areas, levels of service, and acceptance criteria are typical components of which document?

- A. Business case

- B. Work breakdown structure
- C. Requirements documentation
- D. Risk register

**Answer: C (LEAVE A REPLY)**

Section: Executing

Explanation/Reference:

**NEW QUESTION: 615**

A verbal announcement is made that the new team member joining the Scrum team has limited mobility. The scrum master is aware that some team members are unsure how the dynamics of the team will change. What should the scrum master do?

- A. Update the team charter accordingly.
- B. Create a stakeholder engagement plan.
- C. Set up a meeting to discuss accommodations the team will have to make.
- D. Design a communications management plan.

**Answer: (SHOW ANSWER)**

**NEW QUESTION: 616**

What is the purpose of the responsibility assignment matrix project management tool?

- A. It is used to develop the work breakdown structure taking the available resources into account.
- B. It is to make certain that all team members comprehend what their roles entail.
- C. It provides a graphical representation of the project's organizational structure.
- D. It is used to establish team members' availability to engage with the project.

**Answer: B (LEAVE A REPLY)**

**Valid PMP Dumps** shared by PrepPdf.com for Helping Passing PMP Exam! PrepPdf.com now offer the **newest PMP exam dumps**, the PrepPdf.com PMP exam **questions have been updated** and **answers have been corrected** get the **newest** PrepPdf.com PMP dumps with Test Engine here: <https://www.preppdf.com/PMI/PMP-prepaway-exam-dumps.html> (2045 Q&As Dumps, **40%OFF Special Discount: Exam-Tests**)

**NEW QUESTION: 617**

Which of the following statements concerning bottom-up estimating is true?

- A. Larger work items increase both cost and accuracy.
- B. The cost and accuracy of bottom-up estimating is driven by the size of the individual work items.
- C. A and B
- D. Smaller work items increase both cost and accuracy.
- E. A and C

**Answer: C ([LEAVE A REPLY](#))**

**NEW QUESTION: 618**

You have assembled a core team to develop the project management plan for the next generation of fatigue fighting drugs. The science is complex, and the extended team of researchers, clinicians, and patients for trials exceeds 500 people. The content of your project management plan will be directed primarily by two factors. They are\_\_\_\_\_.

- A. Project complexity and the capability of resources
- B. Number of resources and project schedule
- C. Team member experience and budget
- D. Application area and complexity

**Answer: D ([LEAVE A REPLY](#))**

Explanation/Reference:

Explanation:

The content of the project management plan is primarily influenced by the application area [in this case drug development] and complexity of the project. The size of the plan is typically commensurate with the size and complexity of the project.

**NEW QUESTION: 619**

You are managing a project in which your team members all work in the same geographic location and have worked together previously on many projects. Everyone is aware of the various strengths and weaknesses of the individual team members and their key areas of expertise. As a result\_\_\_\_\_

- A. A kickoff meeting is recommended
- B. Team-building activities will not be needed on your project
- C. You should expect minimal conflicts and changes to occur
- D. Rewards and recognition will be handled smoothly throughout the project

**Answer: A ([LEAVE A REPLY](#))**

Explanation/Reference:

Explanation:

Even if team members already know one another, a kickoff meeting should still be held because the meeting always includes more than meeting team members. Specific expectations for the project can be discussed as well as other important administrative details. It also gives people an opportunity to express their commitment to the project's objectives.

**NEW QUESTION: 620**

An input to the Identify Risks process is the:

- A. Risk register.
- B. Risk probability and impact assessment.
- C. Communications management plan.
- D. Risk management plan.

**Answer: (SHOW ANSWER)**

Section: Planning

**NEW QUESTION: 621**

Which of the following statements are FALSE regarding the critical chain method?

- A. CCM factors in resource availability limitations when constructing the project schedule
- B. In CCM, uncertainty is managed by padding task duration, starting work as early as possible, and multi-tasking
- C. The critical chain describes longest path through a project schedule network after resource leveling
- D. The CCM uses, aggregate problem buffers in the project plan instead of individual activity/ task buffer
- E. CCM focuses on managing buffer activity duration in lieu of managing the total float of network paths

**Answer: B (LEAVE A REPLY)**

**NEW QUESTION: 622**

A project manager has identified project stakeholders and assessed their power and influence. These stakeholders are all busy with other high-priority projects. The project manager wants to ensure that identified high-power and high-influence stakeholders have the information required to support effective decision making.

What should be maintained to keep these stakeholders current on progress and issues?

- A. Communications management plan and project charter
- B. Risk register and issue log
- C. Project management plan updates, project document updates, and risk register
- D. Issue log change requests, and project management plan updates

**Answer: C (LEAVE A REPLY)**

**NEW QUESTION: 623**

A company is working on a project and is using a hybrid approach to streamline a customer service process. At the end of the second iteration, a business analyst joins the team to learn about the financial and scheduling aspects of project management.

What should the project manager do to support the business analyst?

- A. Ask the business analyst to focus on their work allocation for the needs of the project
- B. Create reports to inform the business analyst about the schedule and project cost
- C. Assign resources to coach the business analyst
- D. Provide the business analyst with access to the financial and scheduling information

**Answer: D (LEAVE A REPLY)**

**NEW QUESTION: 624**

One deliverable for a project is to translate and print materials for students every 2 weeks. Printing services are available but without guaranteed time lines because other projects make a significantly higher profit and have a higher priority. What should the project manager do to mitigate the risk of not having the materials printed on time?

- A. Include a risk response in the resource management plan
- B. Purchase a high-volume printer specifically for this project.
- C. Create a change request to modify the print requirements
- D. Meet with the manager to set a high priority for printing the materials

**Answer: A (LEAVE A REPLY)**

#### **NEW QUESTION: 625**

Project cost management must consider the effect of project decisions on the cost of the product created by the project. Your objective to reduce cost and time, improve quality and performance, and optimize decision making can be facilitated using tools like: (select best answer)

- A. Payback Period
- B. Value Engineering and Life Cycle Costing
- C. Value Engineering
- D. Life Cycle Costing

**Answer: B (LEAVE A REPLY)**

#### **NEW QUESTION: 626**

The Project Human Resource Management process that involves confirming human resource availability and obtaining the team necessary to complete project activities is:

- A. Acquire Project Team.
- B. Manage Project Team.
- C. Develop Project Team.
- D. Plan Human Resource Management.

**Answer: A (LEAVE A REPLY)**

#### **NEW QUESTION: 627**

Which is not output from Control Schedule:

- A. Revisions
- B. Lessons learned
- C. Schedule updates
- D. Corrective action

**Answer: A (LEAVE A REPLY)**

Outputs of Control Schedule: Schedule updates, Corrective action and Lessons learned

#### **NEW QUESTION: 628**

The government sponsors a project to construct a new highway. The assigned project manager communicates to stakeholders that the project charter was approved. The project manager is

working on the project management plan and receives an email from an environmental organization asking for the objectives and start date of the project.

What should the project manager do to address the situation?

- A. Conduct a stakeholder analysis and communicate to stakeholders accordingly.
- B. Respond to the email with the requested information.
- C. Conduct a brainstorming session with the stakeholders and the team
- D. Update the communications management plan accordingly.

**Answer:** ([SHOW ANSWER](#))

Section: Executing

### **NEW QUESTION: 629**

A recently promoted project manager must facilitate the weekly status update meeting, what should the project manager do to ensure a productive meeting?

- A. Avoid or smooth over any disagreements.
- B. Carefully read the latest meeting minutes.
- C. Limit attendance to the project team and stakeholders.
- D. Circulate a defined agenda in advance.

**Answer:** D ([LEAVE A REPLY](#))

### **NEW QUESTION: 630**

Every project creates a unique product, service, or result that may be:

- A. targeted
- B. tangible
- C. variable
- D. organized

**Answer:** B ([LEAVE A REPLY](#))

### **NEW QUESTION: 631**

Keeping up with the growth was becoming a problem for a privately owned Chinese financial services company. Although it easily lured business from state-owned competitors, low skill levels and weak accounting systems threaten the company's cash flow. Moreover, poorly invested assets were delivering inadequate returns. Hence, you have been assigned over an existing project to upgrade the IT system to allow for an expansion. Specifically, the IT upgrade will enable the company to serve more competitors, expand the product line, gain market share, and win more licenses.

You've determined the following information so far: Activity X has an early start of day3, early finish of day6, and a late finish of day10. Activity Y is being performed by resource that had been very difficult to obtain. The CPI of the project is 1.2 and the SPI is 0.9. Based on the information above, which of the following areas should cause the MOST concern?

- A. Float
- B. Resources

- C. Cost
- D. Quality
- E. Schedule

**Answer: E** ([LEAVE A REPLY](#))

**Valid PMP Dumps** shared by PrepPdf.com for Helping Passing PMP Exam! PrepPdf.com now offer the **newest PMP exam dumps**, the PrepPdf.com PMP exam **questions have been updated** and **answers have been corrected** get the **newest** PrepPdf.com PMP dumps with Test Engine here: <https://www.preppdf.com/PMI/PMP-prepaway-exam-dumps.html> (2045 Q&As Dumps, **40%OFF Special Discount: Exam-Tests**)

**NEW QUESTION: 632**

A project manager arranges quality management training for the entire project team. The training will relate to the project's final product deliverable.

In what cost of quality (COQ) category should the project manager classify this training?

- A. Internal failure
- B. Prevention
- C. External failure
- D. Appraisal

**Answer: (SHOW ANSWER)**

Section: Monitoring and Controlling

**NEW QUESTION: 633**

Which of the following is a tool and technique used in the Develop Schedule process?

- A. Resource leveling
- B. Precedence diagramming method
- C. Three-point estimates
- D. Bottom-up estimating

**Answer: A** ([LEAVE A REPLY](#))

**NEW QUESTION: 634**

A company notices that. During the last six projects, the scope changed substantially. What should the project manager of a new project do first to reduce the likelihood of scope changes?

- A. Ask for management's guidance.
- B. Review lessons learned from the previous projects.
- C. Review the project scope statement.
- D. Plan to mitigate the impact of scope change

**Answer: B** ([LEAVE A REPLY](#))

**NEW QUESTION: 635**

A recently promoted project manager must facilitate the weekly status update meeting. What should the project manager do to ensure a productive meeting?

- A. Carefully read the latest meeting minutes.
- B. Avoid or smooth over any disagreements.
- C. Limit attendance to the project team and stakeholders.
- D. Circulate a defined agenda in advance.

**Answer: (SHOW ANSWER)**

Section: Executing

**NEW QUESTION: 636**

A project manager identifies a risk and its possible impact. The project manager notifies the sponsor that sufficient budget, schedule, and other resources have been allocated to respond to the risk if it occurs.

What risk response strategy did the project manager use?

- A. Avoid
- B. Accept
- C. Mitigate
- D. Transfer

**Answer: C (LEAVE A REPLY)**

Section: Planning

**NEW QUESTION: 637**

Two years back, your organization awarded a fixed price contract to a reputable local contractor to construct a new airport terminal in your city. During the execution of the project, some disputes arose over the scope and quality of the work. You have negotiated with the contractor to solve the problem. However, the problem has not been resolved. Which of the following methods should be your first course of action to resolve this issue?

- A. Alternative dispute resolution (ADR)
- B. Claims court
- C. Negotiation
- D. Appeals court

**Answer: (SHOW ANSWER)**

**NEW QUESTION: 638**

Performing the administrative closure process includes all of the following EXCEPT:

- A. Analyze project success or failure
- B. Gather lessons learned
- C. Review and approve requested changes
- D. Archive project information
- E. Collect project records

**Answer: C ([LEAVE A REPLY](#))**

**NEW QUESTION: 639**

Name the ethical code you'll be required to adhere to as a PMP.

- A. Project Management Policy and Ethics Guide
- B. Project Management Professional Standards and Ethics
- C. Project Management Code of Professional Ethics
- D. Project Management Professional Code of Professional Conduct

**Answer: ([SHOW ANSWER](#))**

The Project Management Professional Code of Professional Conduct is published by PMI, and all PMPs are expected to adhere to its standards.

**NEW QUESTION: 640**

Definitions of probability and impact, revised stakeholder tolerances, and tracking are components of which subsidiary plan?

- A. Cost management plan
- B. Quality management plan
- C. Communications management plan
- D. Risk management plan

**Answer: D ([LEAVE A REPLY](#))**

Section: Planning

**NEW QUESTION: 641**

Who is responsible for issuing the project charter?

- A. The project sponsor
- B. The senior Project Manager
- C. The project team
- D. The project manager

**Answer: A ([LEAVE A REPLY](#))**

The project sponsor creates and issues the project charter.

**NEW QUESTION: 642**

How is the schedule variance calculated using the earned value technique?

- A. AC less PV
- B. EV less AC
- C. EV less PV
- D. AC less EV

**Answer: C ([LEAVE A REPLY](#))**

**NEW QUESTION: 643**

The initial cost of a product and the product's operation and maintenance costs \_\_\_\_\_ .

- A. decreases design costs as operation periods increase
- B. are integrally related with each other because initial costs are "sunk".
- C. provides perceived function value and product social dysfunction
- D. increases perceived value when balanced.
- E. are incidental to each other because initial costs are "sunk"

**Answer: D (LEAVE A REPLY)**

**NEW QUESTION: 644**

Which of the Perform Quality Assurance tools and techniques may enhance the creation of the work breakdown structure (WBS) to give structure to the decomposition of the scope?

- A. Affinity diagrams
- B. Matrix diagrams
- C. Activity network diagrams
- D. Interrelationship digraphs

**Answer: A (LEAVE A REPLY)**

**NEW QUESTION: 645**

Which of the following compression techniques increases risk?

- A. Fast tracking
- B. Crashing
- C. Lead and lag
- D. Resource leveling

**Answer: A (LEAVE A REPLY)**

Fast tracking is a compression technique that increases risk and potentially causes rework

**NEW QUESTION: 646**

A new member was included on a project team in an ongoing software project. This team member was the only available resource but does not have the proper experience to accomplish the activities.

What should the project manager do to ensure this team member's lack of experience does not negatively impact the project?

- A. Ensure that coaching meetings are in place for this team member within the project timeline.
- B. Schedule a training course for the new team member to fill in their gaps in experience.
- C. Log this as an issue in the project issue log and speak with the resource manager.
- D. Provide weekly feedback to all project team members, including the new member.

**Answer: A (LEAVE A REPLY)**

**updated and answers have been corrected** get the **newest** PrepPdf.com PMP dumps with Test Engine here: <https://www.preppdf.com/PMI/PMP-prepaway-exam-dumps.html> (2045 Q&As Dumps, **40%OFF Special Discount: Exam-Tests**)

**NEW QUESTION: 647**

A project scope was developed with numerous assumptions. During the execution phase, the assumptions changed, which has jeopardized the planned business value of the project.

% What should the project manager do next?

- A. Inform the client that the project cannot meet the project timeline and additional costs will be incurred.
- B. Report on the changed assumptions to the project sponsor and seek support to prioritize the change requests.
- C. Update the assumptions log and change log, and implement the change control process.
- D. Deliver what was planned in the project management document according to the specifications.

**Answer: B** ([LEAVE A REPLY](#))

**NEW QUESTION: 648**

An external audit concludes that a project is six to 12 months behind schedule. The project manager and the project team agree. What should the project manager do next?

- A. Initiate the change request process
- B. Revise the work breakdown structure (WBS)
- C. Set a new project schedule baseline
- D. Update the risk register

**Answer: D** ([LEAVE A REPLY](#))

**NEW QUESTION: 649**

A project manager for a US\$15 million construction project must meet a specific project milestone earlier than planned because a season-long pattern of extreme weather is expected soon. The project is already over budget, and the project sponsor is not prepared to provide additional funding.

Which tool or technique should the project manager use to achieve the milestone before the extreme weather begins?

- A. Crashing
- B. Simulation
- C. Fast tracking
- D. Resource smoothing

**Answer: (**[SHOW ANSWER](#)**)**

**NEW QUESTION: 650**

You are the project manager of a project .You have just completed the Collect

Requirements and Define Scope. What should you do next?

- A. Control Scope
- B. Create WBS
- C. Value analysis
- D. Verify Scope

**Answer: (SHOW ANSWER)**

Create the WBS is the process that follows Collect Requirements and Define Scope.

### NEW QUESTION: 651

Major difficulties arise when multiple projects need to be managed in the functional organizational structure because of \_\_\_\_\_

- A. The level of authority of the project manager
- B. Conflicts over the relative priorities of different projects in competition for limited resources
- C. Project team members who are focused on their functional specialty rather than on the project
- D. The need for the project manager to use interpersonal skills to resolve conflicts informally

**Answer: B (LEAVE A REPLY)**

Explanation/Reference:

Explanation:

When a finite group of resources must be distributed across multiple projects, conflicts in work assignments will occur.

### NEW QUESTION: 652

Which of the following would most likely increase the accuracy of estimating the project cost?

- A. Both 1) Pricing out the work at lower levels in the work breakdown structure, and 2) Talking to people who have worked on similar projects.
- B. Talking to people who have worked on similar projects.
- C. 1) Pricing out the work at lower levels in the work breakdown structure, and 2) Talking to people who have worked on similar projects, and 3) Using historical data.
- D. Using historical data.
- E. Pricing out the work at lower levels in the work breakdown structure.

**Answer: (SHOW ANSWER)**

### NEW QUESTION: 653

For an agile pilot project, the sponsor arranged an early product demonstration for the customer. During the meeting, the customer realizes that a new feature will significantly improve the product. After collecting the new requirements, what should the project manager do?

- A. Assess the impact and communicate the updated product roadmap to the stakeholders.
- B. Follow the change management plan to update the risk register so it accounts for the added scope.
- C. Work with the product manager and the rest of the team to update the project backlog.
- D. Assess the impact of the new requirements and initiate the change request process.

**Answer: D ([LEAVE A REPLY](#))**

**NEW QUESTION: 654**

You are managing a major international project, and your contract requires you to prepare both a project plan and a quality management plan. Your core team is preparing a project quality management plan. Your first step in developing this plan is to\_\_\_\_\_

- A.** Determine specific metrics to use in the quality management process
- B.** Identify the quality standards for the project
- C.** Develop a quality policy for the project
- D.** Identify specific quality management roles and responsibilities for the project

**Answer: C ([LEAVE A REPLY](#))**

Section: Mix Questions

Explanation:

The quality policy includes the overall intentions and direction of the organization with regard to quality, as formally expressed by top management. If the performing organization lacks a formal quality policy or if the project involves multiple performing organizations, as in a joint venture, the project management team must develop a quality policy for the project. The quality management plan then describes how the quality policies will be implemented.

**NEW QUESTION: 655**

Drag the to the correct scenario on the right

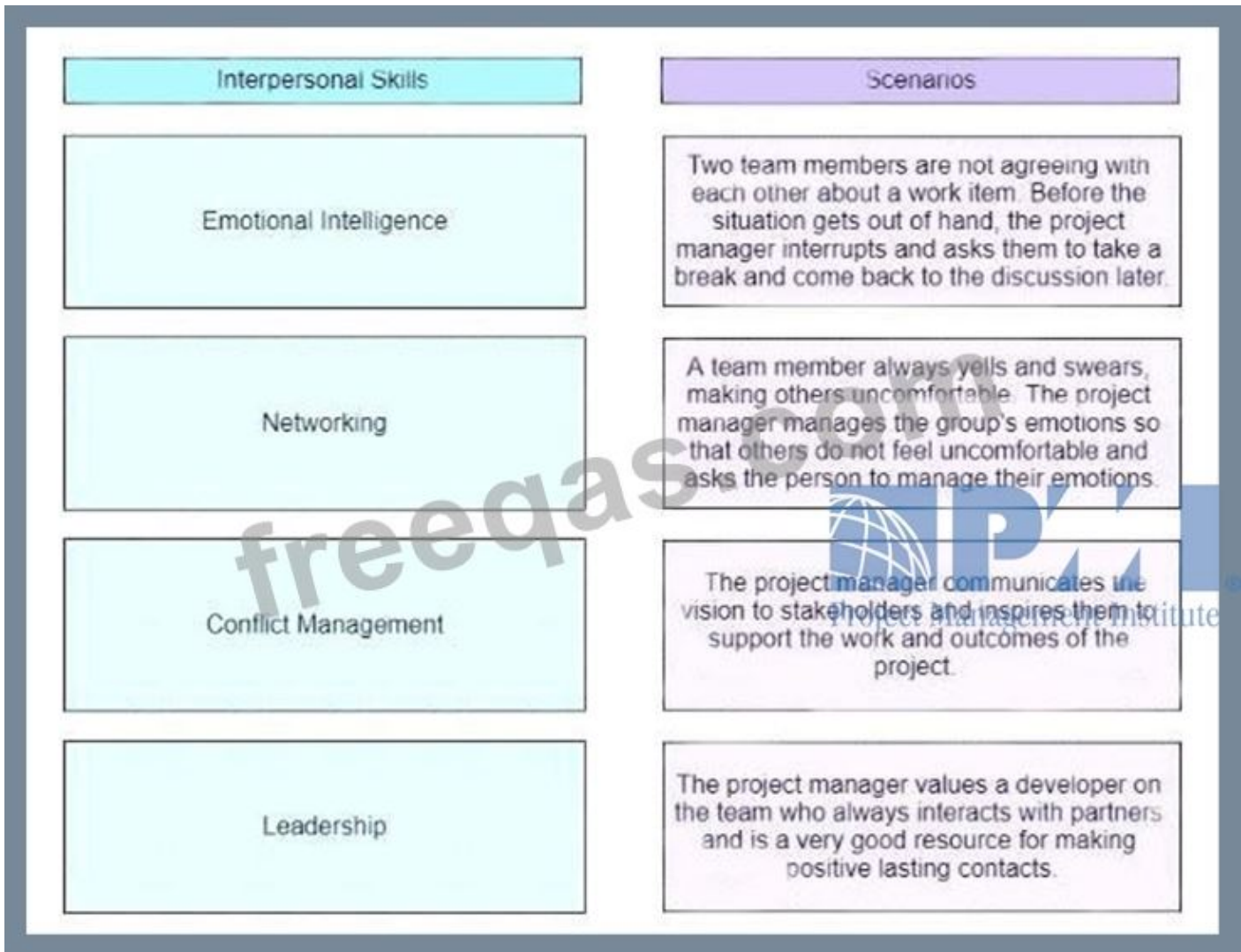

**Answer:**

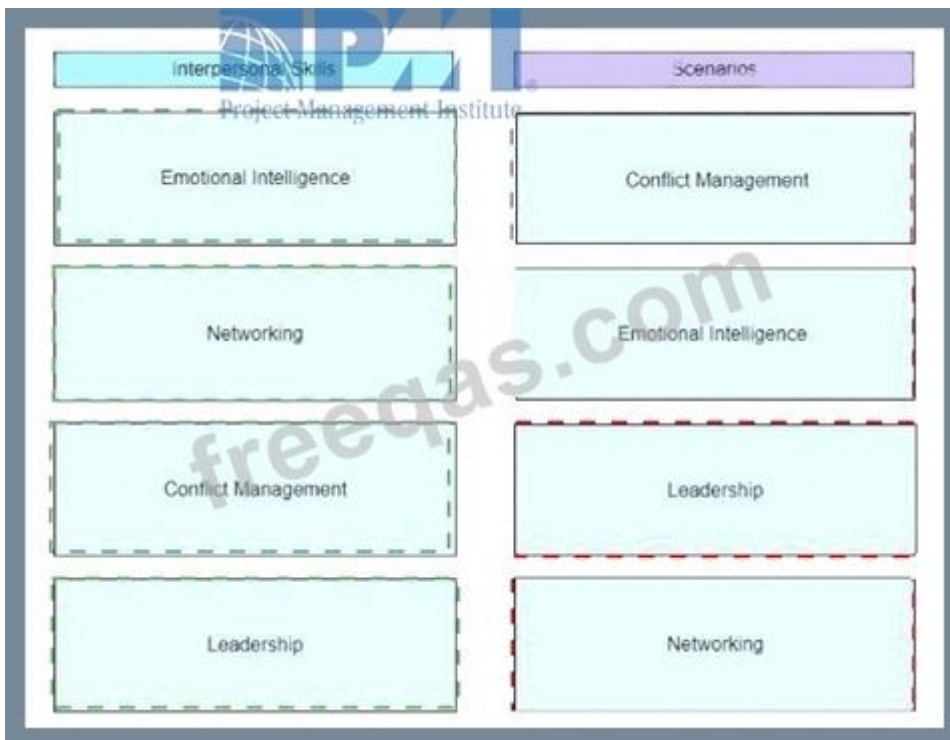

**Explanation**



**NEW QUESTION: 656**

During a retrospective, one of the team members reports that a functional manager wants to be involved in task allocation. What should the project manager do?

- A. Confirm with the team members that the functional manager is responsible for the delivery.
- B. Inform the functional manager that self-organization includes task allocation.
- C. Ask the product owner to clarify the roles and responsibilities of the project team.
- D. Inform the functional manager that task allocation is the responsibility of the product owner.

**Answer:** ([SHOW ANSWER](#))

**NEW QUESTION: 657**

Which organizational process assets update is performed during the Close Procurements process?

- A. Procurement audit
- B. Lessons learned
- C. Performance reporting
- D. Payment requests

**Answer:** B ([LEAVE A REPLY](#))

Section: Closing

**NEW QUESTION: 658**

A project manager is archiving project documentation for a recently completed project. The project sponsor is satisfied with project results and wants the project manager to stop archiving and immediately lead a new strategic project. What should the project manager do?

- A. Ad according to the sponsor's request
- B. insist on finishing the archiving and point out its importance to the project sponsor
- C. Ask the sponsor for formal approval to stop archiving project documents.
- D. Propose a compromise by keeping a local project archive on the project manager's computer

**Answer: B ([LEAVE A REPLY](#))**

#### **NEW QUESTION: 659**

Which standard has interrelationships to other project management disciplines such as program management and portfolio management?

- A. Program Management Body of Knowledge Guide
- B. The Standard for Program Management
- C. Organizational Project Management Maturity Model (OPM3)
- D. Guide to the Project Management Body of Knowledge (PMBOK)

**Answer: ([SHOW ANSWER](#))**

Section: Initiation

#### **NEW QUESTION: 660**

During a weekly project meeting, the team members and stakeholders complain about receiving a large number of daily emails. What should the project manager do?

- A. Reduce the maximum number of emails to be sent on a daily basis.
- B. Create an online shared cloud to store emails to enhance communication.
- C. Launch a kick-off meeting to establish a stakeholder responsibility matrix.
- D. Refer to the project's communications management plan.

**Answer: ([SHOW ANSWER](#))**

Section: Monitoring and Controlling

#### **NEW QUESTION: 661**

From prior experience with an organization, a project manager is aware of the possibility that key resources may be reassigned to other, more urgent projects. What should this project manager update to ensure that other project managers are also aware of this?

- A. Lessons learned repository
- B. Risk register
- C. Communications management plan
- D. Project documents

**Answer: ([SHOW ANSWER](#))**

**Valid PMP Dumps** shared by PrepPdf.com for Helping Passing PMP Exam! PrepPdf.com now offer the **newest PMP exam dumps**, the PrepPdf.com PMP exam **questions have been updated** and **answers have been corrected** get the **newest** PrepPdf.com PMP dumps with Test Engine here: <https://www.preppdf.com/PMI/PMP-prepaway-exam-dumps.html> (2045 Q&As Dumps, **40%OFF Special Discount: Exam-Tests**)

**NEW QUESTION: 662**

All of the following are reasons for outsourcing work except...

- A. Your company doesn't have excessive capacity for the work
- B. Your company doesn't possess the skills needed for the work
- C. Your company isn't concerned about protecting the information associated with the work
- D. Labor rates in the foreign countries are comparable to your company's labor rate

**Answer: D (LEAVE A REPLY)**

Section: Mix Questions

**NEW QUESTION: 663**

Drag the communication event on the left to the main subject discussed during the event on the right.

Communication event	Main subject
Daily meeting	Goal for this iteration
Iteration retrospective	Development flow
Iteration planning	Backlog items completed or not
Iteration review	Continue, stop, or start actions

**Answer:**

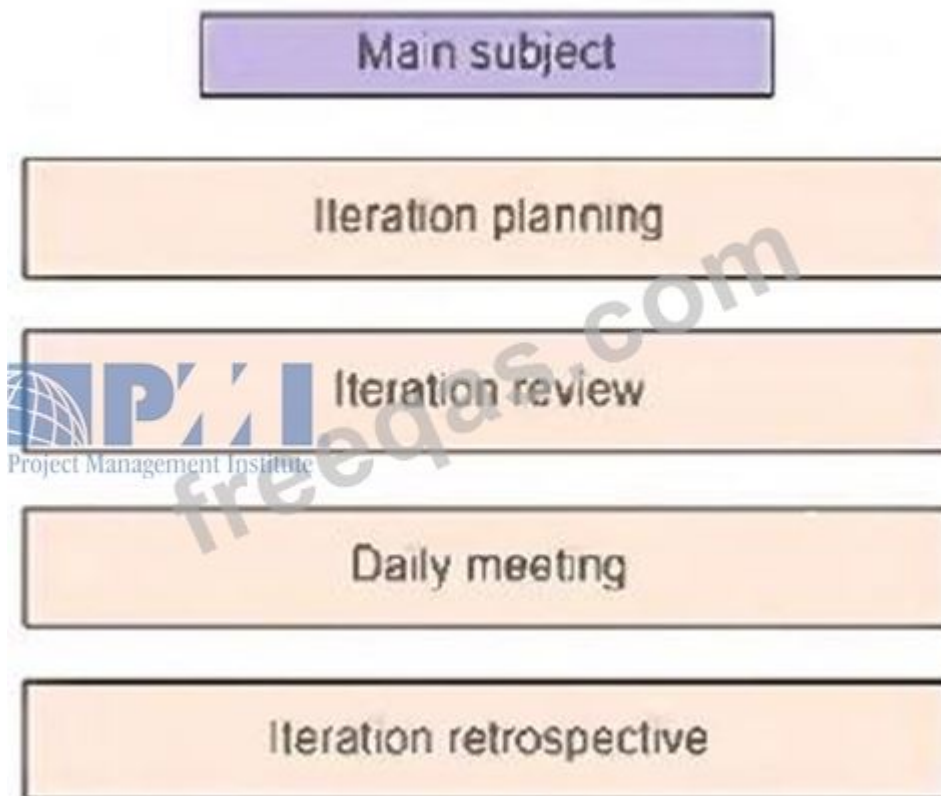
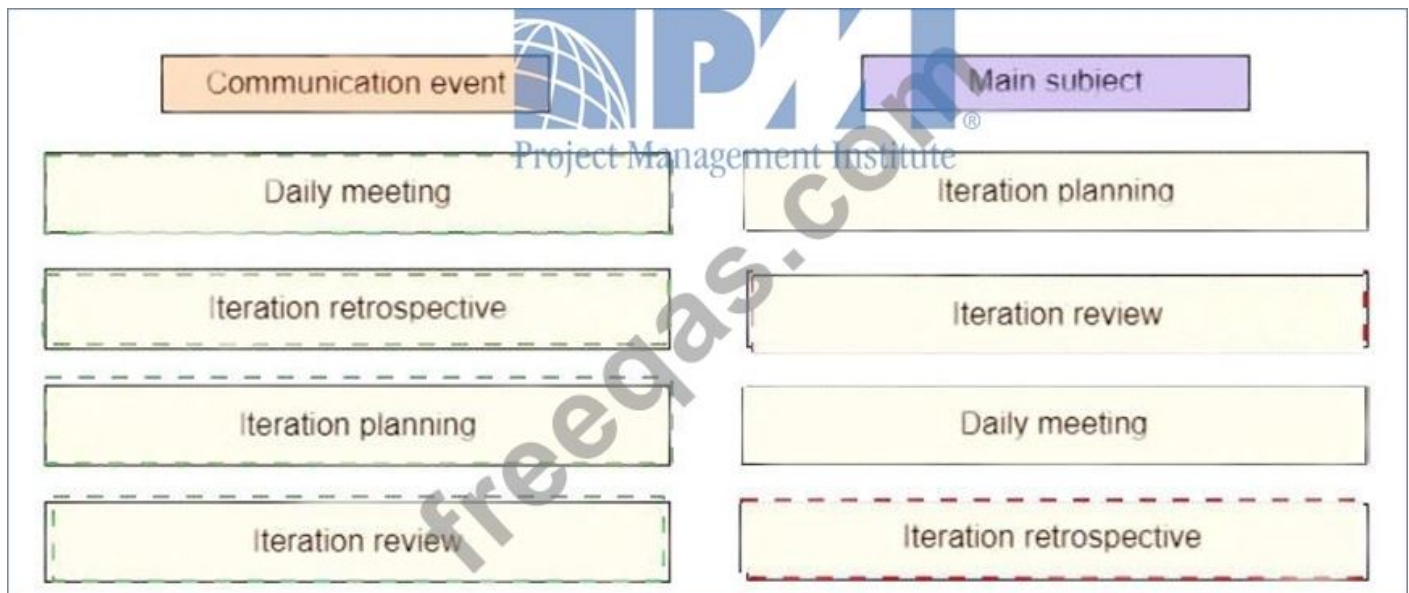

**NEW QUESTION: 664**

Which of the following statements are true about the work breakdown structure?

- A. The work breakdown structure is a detailed management process
- B. None of the above
- C. Each level represents an increasing level of detail
- D. The work breakdown structure is deliverable oriented

**Answer: D** ([LEAVE A REPLY](#))

**NEW QUESTION: 665**

The following is a network diagram for a project.

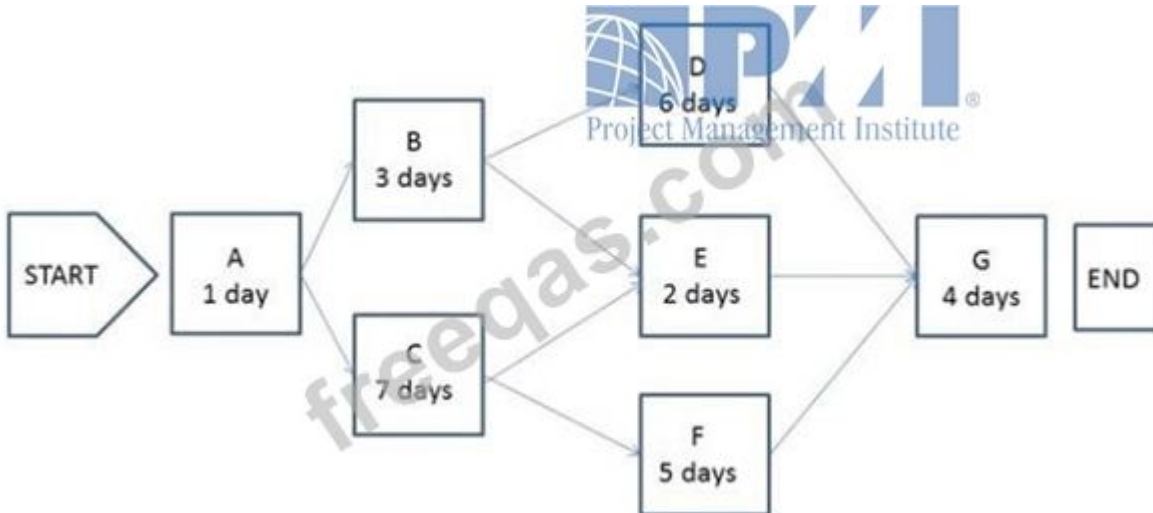

The shortest non-critical path for the project is how many days in duration?

- A. 14
- B. 16
- C. 12
- D. 10

**Answer: D (LEAVE A REPLY)**

#### NEW QUESTION: 666

One year into a five-year project, the project manager realizes that the reason for high team turnover is that the team does not receive the same financial allowances as other teams that are working on the same project. The project manager forecasts that with this high staff turnover rate, the project will suffer a two and-a-half-year delay. The amount to cover additional disbursements was not included in the contract, and the project sponsor is unwilling to renegotiate.

What should the project manager do?

- A. Escalate the problem to the organization's program or portfolio management office (PMG)
- B. Present a change request to reduce scope to the project sponsor.
- C. Request a schedule extension,
- D. Pay disbursements using budget reserves.

**Answer: (SHOW ANSWER)**

#### NEW QUESTION: 667

The outcome that must be produced to complete a part of a project or the project itself is called a \_\_\_\_\_?

- A. WBS
- B. Project Plan
- C. Work Statement
- D. Deliverable

**Answer: D (LEAVE A REPLY)**

The outcome that must be produced to complete a part of a project or the project itself is called a Deliverable.

**NEW QUESTION: 668**

A project manager is conducting testing on product attributes. What should the project manager use to validate compliance?

- A. Quality metrics
- B. Quality audits
- C. Quality reports
- D. Quality checklists

**Answer: A** ([LEAVE A REPLY](#))

**NEW QUESTION: 669**

A project manager is assigned to a project that is in development. As the project manager reviews the project's progress, they find a few tasks that are behind schedule. After investigating the project manager discovers that a few team members were pulled to work on other assignments, which impacted their ability to focus on the project manager's project. Which two actions can the project manager take to bring the team back on track? (Choose two)

- A. Alert the business stakeholders immediately of the schedule delay.
- B. Discuss the risk of project delay and work priorities with the respective functional managers.
- C. Work with the team to identify options to accelerate project delivery.
- D. Allow the team members to catch up at their own pace.
- E. Establish daily standups to review project progress and track the completion of deliverables.

**Answer: (**[SHOW ANSWER](#)**)**

**NEW QUESTION: 670**

An organization is transitioning to agile and a project has been chosen as a pilot. The assigned project manager only has experience using predictive approaches but the project manager is now required to use agile approaches with the help of an agile coach. During the retrospective of the fifth sprint, the project team complains that many obstacles exist with the organization that are creating project delays and rework. What should the project manager do in this situation?

- A. Create a dedicated sprint to solve the obstacles with the team.
- B. Include impediment resolutions during daily standup meetings.
- C. Perform a root cause analysis during the standup meetings.
- D. Promote collaboration to help remove the obstacles for the team.

**Answer: (**[SHOW ANSWER](#)**)**

**NEW QUESTION: 671**

You are working on a project and want to identify the cause of problems in a process by the shape and width of the distribution of the process variables. You should use a \_\_\_\_\_

- A. Histogram

- B. Pareto chart
- C. Scatter diagram
- D. Trend analysis

**Answer: A ([LEAVE A REPLY](#))**

Explanation/Reference:

Explanation:

In a histogram, or a special form of bar chart, each column represents an attribute or characteristic of a problem or situation. The height of each column represents the relative frequency of the characteristic. It describes the central tendency, dispersion, or shape of a statistical distribution.

#### **NEW QUESTION: 672**

A project manager identifies a risk for a complex module in a project. Before executing work on this module, a technical specialist suggests adopting a proven technology rather than using a new, experimental technology.

The project manager accepts this suggestion.

What risk response strategy did the project manager use?

- A. Share
- B. Avoid
- C. Mitigate
- D. Transfer

**Answer: B ([LEAVE A REPLY](#))**

#### **NEW QUESTION: 673**

You are the project manager for a cable service provider. Your project team is researching a new service offering. They have been working together for quite some time and are in the performing stage of Develop Project Team. This stage of Develop Project Team is similar to which of the following?

- A. Achievement Theory
- B. Self-actualization
- C. Smoothing
- D. Hygiene Theory

**Answer: ([SHOW ANSWER](#))**

The performing stage is similar to Maslow's self-actualization. Both involve team members at the peak of performance, concerned with doing good and being the best.

#### **NEW QUESTION: 674**

The most effective team motivator is:

- A. the visibility of the team's contribution
- B. the satisfaction of meeting a challenge
- C. All of the other alternatives apply.

- D. understanding the importance of the project
- E. the individual's professional challenge

**Answer: A (LEAVE A REPLY)**

**NEW QUESTION: 675**

What is the tool and technique used to request seller responses?

- A. Contract types
- B. Expert judgment
- C. Bidder conferences
- D. Procurement documents

**Answer: C (LEAVE A REPLY)**

**NEW QUESTION: 676**

What provides information regarding the ways people, teams, and organizational units behave?

- A. Organizational chart
- B. Organizational theory
- C. Organizational structure
- D. Organizational behavior

**Answer: (SHOW ANSWER)**

Section: Executing

Explanation/Reference:

**Valid PMP Dumps** shared by PrepPdf.com for Helping Passing PMP Exam! PrepPdf.com now offer the **newest PMP exam dumps**, the PrepPdf.com PMP exam **questions have been updated** and **answers have been corrected** get the **newest** PrepPdf.com PMP dumps with Test Engine here: <https://www.preppdf.com/PMI/PMP-prepaway-exam-dumps.html> (2045 Q&As Dumps, **40%OFF Special Discount: Exam-Tests**)

**NEW QUESTION: 677**

Which items are components of a project management plan?

- A. Schedule management plan, project schedule, and resource calendars
- B. Agreements, procurement management plan, and work performance information
- C. Change management plan, process improvement plan, and scope management plan
- D. Scope baseline, project statement of work, and requirements traceability matrix

**Answer: C (LEAVE A REPLY)**

**NEW QUESTION: 678**

A project manager is managing a project which is approaching the end of the execution phase. A high-level stakeholder informs the project manager that a very important requirement was not

included in the scope of the project, and that without that requirement the project will deliver no value.

What is the first thing the project manager should do"?

- A. Evaluate the impact that the inclusion of this new requirement will have on project performance
- B. Inform the stakeholder that it is impossible to add new requirements to an approved project scope
- C. Inform the project sponsor about the situation and request assistance
- D. Include the requirement into the project and schedule it as soon as possible

Answer: ([SHOW ANSWER](#))

**NEW QUESTION: 679**

Drag the characteristics of the stage on the left to the correct Tuckman Ladder stage on the right

Characteristics

Stages

Team members argue and are not openly collaborative

Members are reassigned to other projects

Team members are independent and work in silos

Members adjust their work habits with trust

Members are independent and work effectively

Forming

Storming

Norming

Performing

Adjourning

Answer:

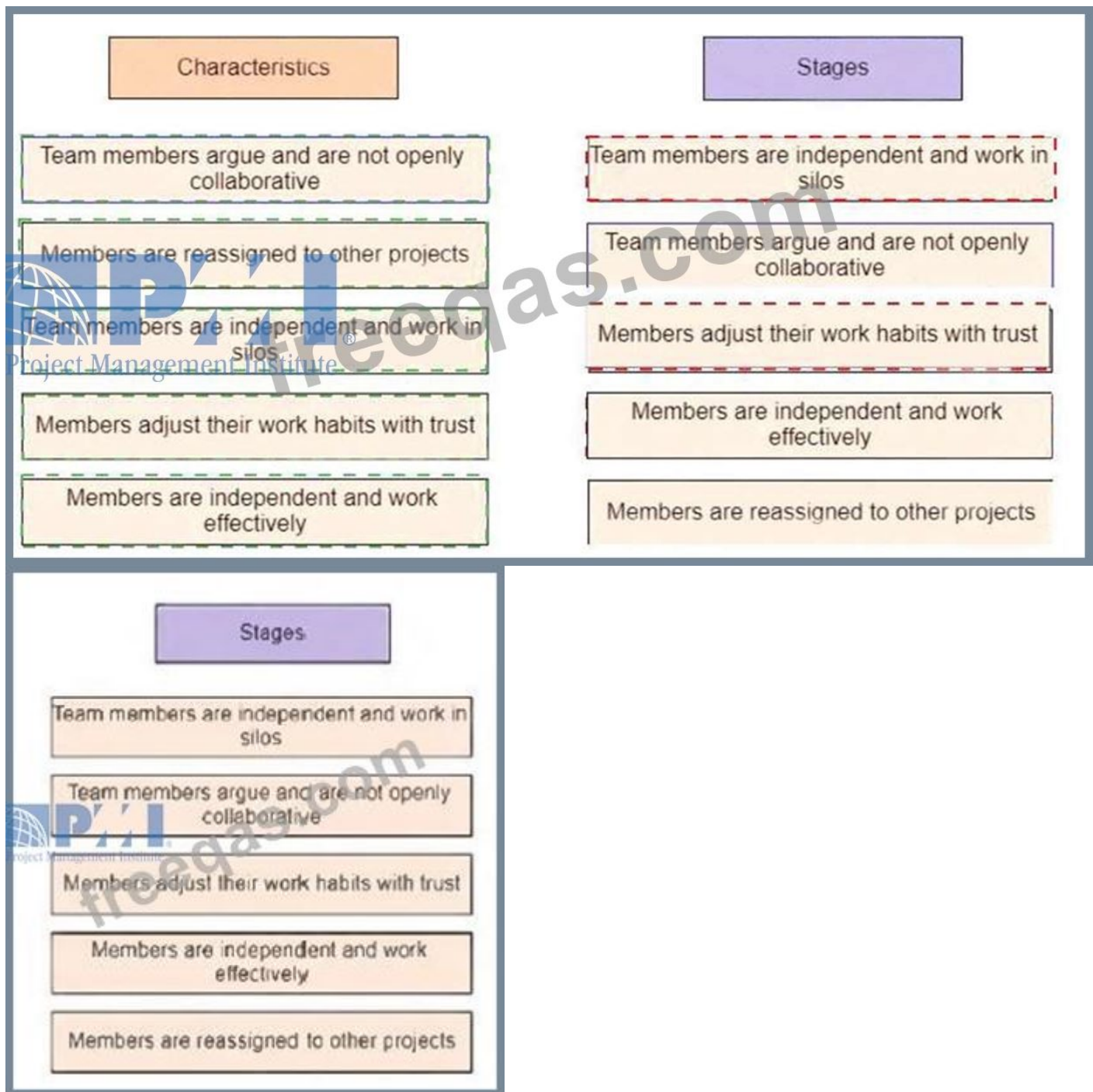

**NEW QUESTION: 680**

Which type of analysis would be used for the Plan Quality process?

- A. Schedule
- B. Checklist
- C. Assumption
- D. Cost-Benefit

**Answer: D (LEAVE A REPLY)**

Section: Executing

**NEW QUESTION: 681**

The ISO 9000 standards provide\_\_\_\_\_

- A. A description of how products should be produced
- B. Specifics for the implementation of quality systems
- C. A framework for quality systems
- D. The maximum process requirements necessary to ensure that customers receive a good product

**Answer: (SHOW ANSWER)**

Section: Mix Questions

Explanation:

ISO 9000 provides a basic set of requirements for a quality system, without specifying the particulars for implementation.

### **NEW QUESTION: 682**

Midway through project execution, several stakeholders raise concerns about team performance schedule.

What should the project manager do next?

- A. Ask the project sponsor to intervene.
- B. Email the stakeholders to assure them of action.
- C. Ask stakeholders to escalate their concerns to the CEO.
- D. Consult the communications management plan to manage stakeholders' expectations.

**Answer: D (LEAVE A REPLY)**

### **NEW QUESTION: 683**

Which of the following is NOT a cost estimation tool or technique?

- A. Bottom-up
- B. Analogous
- C. Parametric
- D. Cost aggregation

**Answer: D (LEAVE A REPLY)**

Cost Aggregation is used to build your budget, but it is not a tool for cost estimation. Bottom-up, Parametric, and Analogous estimation techniques are used for both cost and time estimates.

### **NEW QUESTION: 684**

Work authorization forms are needed in order to:

- A. All of the other alternatives apply
- B. Authorize line organizations to charge against the project
- C. Develop a structured methodology for release of funds
- D. 1) Authorize line organizations to charge against the project and 2)Develop a structured methodology for release of funds
- E. Establish an audit trail

**Answer: A (LEAVE A REPLY)**

**NEW QUESTION: 685**

Coordinating changes across knowledge areas is a function of:

- A. Overall change control
- B. Scope change control
- C. Project plan execution
- D. Baseline management

**Answer: A ([LEAVE A REPLY](#))**

**NEW QUESTION: 686**

Which tool or technique is required in order to determine the project budget?

- A. Cost of quality
- B. Historical relationships
- C. Project management software
- D. Forecasting

**Answer: B ([LEAVE A REPLY](#))**

Section: Planning

**NEW QUESTION: 687**

A project manager is implementing a new software system. Some department staff members are questioning the necessity of the change and feel the new system will impede their current processes. What should the project manager have done at the start of the project to prevent this resistance?

- A. Created a communications management plan that outlined the method of communicating to stakeholders.
- B. Encouraged leadership to discuss the change with departments that are typically resistant to change.
- C. Involved stakeholders from all levels of the company so everyone understands the change.
- D. Ensured that the company culture encourages changes before accepting the project.

**Answer: C ([LEAVE A REPLY](#))**

**NEW QUESTION: 688**

The team you have organized for your new project consists of three people who will work full-time and five people who will support the project on a part-time basis. All team members know one another and have worked together in the past. To ensure a successful project start-up, your first step should be to \_\_\_\_\_.

- A. Meet with each team member individually to discuss assignments.
- B. Prepare a responsibility assignment matrix and distribute it to each team member.
- C. Distribute the project plan and WBS to the team.
- D. Hold a project kickoff meeting.

**Answer: D ([LEAVE A REPLY](#))**

Section: Mix Questions

Explanation:

An indispensable tool in project management, the kickoff or launch meeting is held at the outset of the project and is designed to get the project rolling. The meeting provides the opportunity not only to present the project charter and discuss the project's goals and objectives but also to establish rapport among team members.

**NEW QUESTION: 689**

An important project stakeholder is replaced, and their successor is unhappy with the progress and direction of the project. The new stakeholder wants to implement changes that will cause delays. What should the project manager do?

- A. Ask the project owner to influence the new stakeholder to follow the original plan
- B. Meet with the new stakeholder to gain an understanding of their concerns and expectations
- C. Convince the new stakeholder to maintain the original plan
- D. Escalate the changes to the project sponsor for approval

**Answer: B (LEAVE A REPLY)**

**NEW QUESTION: 690**

The following is a network diagram for a project.

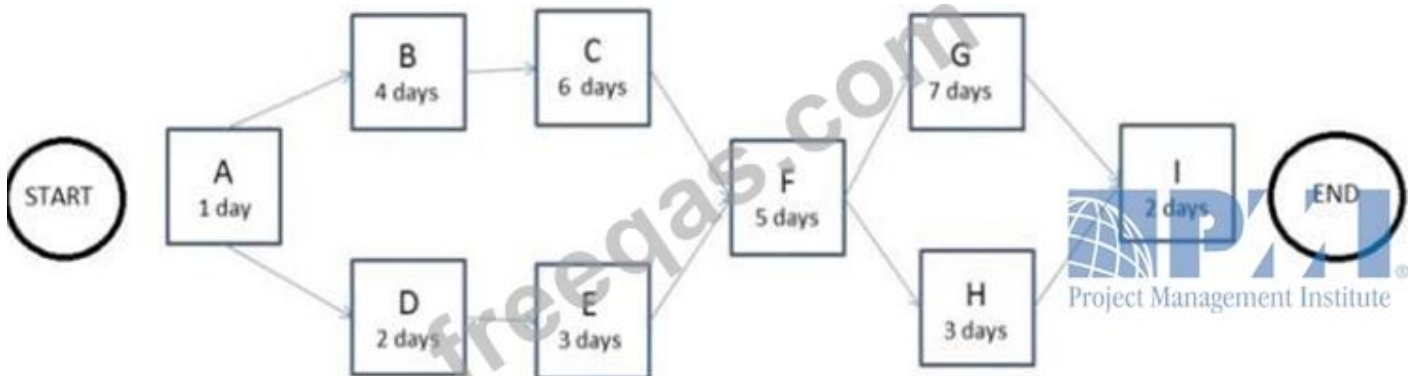

What is the critical path for the project?

- A. A-B-C-F-H-I
- B. A-D-E-F-H-I
- C. A-D-E-F-G-I
- D. A-B-C-F-G-I

**Answer: D (LEAVE A REPLY)**

**NEW QUESTION: 691**

You are in the process of developing an approximation of the costs of the resources needed to complete each schedule activity. All of the following are outputs of this process EXCEPT:

- A. Activity cost estimate supporting detail
- B. Cost baseline
- C. Activity cost estimates
- D. Cost management plan updates

E. Requested changes

Answer: ([SHOW ANSWER](#))

**Valid PMP Dumps** shared by PrepPdf.com for Helping Passing PMP Exam! PrepPdf.com now offer the **newest PMP exam dumps**, the PrepPdf.com PMP exam **questions have been updated** and **answers have been corrected** get the **newest** PrepPdf.com PMP dumps with Test Engine here: <https://www.preppdf.com/PMI/PMP-prepaway-exam-dumps.html> (2045 Q&As Dumps, **40%OFF Special Discount: Exam-Tests**)

**NEW QUESTION: 692**

You are the project manager for a cable service provider. Your project team is researching a new service offering. They have been working together for quite some time and are in the performing stage of team development. A new member has been introduced to the team. Which of the following statements is true?

- A. The team will start all over again at the storming stage but quickly progress to the performing stage.
- B. The team will continue in the performing stage.
- C. The team will start all over again with the storming stage.
- D. The team will start all over again with the forming stage.

Answer: D ([LEAVE A REPLY](#))

The introduction of a new team member will start the formation and development of the team all over again with the forming stage.

**NEW QUESTION: 693**

A project manager realizes that a project is becoming delayed because some key decisions are affected by contradicting views between the organization's senior management and external stakeholders. What should the project manager do?

- A. Isolate the project team from external factors such as senior management and stakeholders so that decisions can be made more quickly
- B. Review the remaining scope and rebaseline the project's schedule to take into account delays in decision making
- C. Review the adequacy of the project's governance and ensure that an appropriate structure is in place
- D. Review the stakeholder register and ensure that communications are being followed in line with the communications management plan.

Answer: D ([LEAVE A REPLY](#))

**NEW QUESTION: 694**

The nature of project work is such that it inevitably causes stress. Project managers thus need to learn how to cope with and manage stress and understand what stress is and why it is created. Project managers need to note that it can be a positive experience depending on how people perceive stress and should work to mentor team members accordingly. As you strive to become more aware of stress, which one of the following is NOT considered a stress-creating factor that is related to the project environment?

- A. Role ambiguity
- B. Corporate politics
- C. Career development
- D. Selection of team members

**Answer: A ([LEAVE A REPLY](#))**

Section: Mix Questions

Explanation

Explanation:

The main sources of stress are grouped into four categories of stress-creating factors: those related to roles and relationships, those related to the job environment, personal factors, and factors related to the project environment or climate. Role ambiguity is an example of factors related to roles and responsibilities.

It occurs when an individual is not clear about his or her job responsibilities.

#### **NEW QUESTION: 695**

The CEO of a company notifies a project manager that a bill from a vendor working on the project amounts to US\$50,000 each month. The CEO questions whether the vendor is meeting the deliverables to determine if the contract should be terminated early. What should be provided to the CEO?

- A. Seller performance evaluation
- B. Contract administration plan
- C. Performance specifications
- D. Procurement management plan

**Answer: A ([LEAVE A REPLY](#))**

#### **NEW QUESTION: 696**

Because a project is behind schedule, the sponsor suggests reducing the time for quality assurance testing.

What should the project manager do?

- A. Perform quality control measurements.
- B. Follow the quality management plan.
- C. Perform quality audits.
- D. Change the quality requirements.

**Answer: D ([LEAVE A REPLY](#))**

Section: Monitoring and Controlling

**NEW QUESTION: 697**

Which of the following correctly explains the term "progressive elaboration"?

- A. Elaborate tracking of the project progress
- B. Changing project specifications continuously
- C. Project specifications becoming more explicit and detailed as the project progresses
- D. Elaborate tracking of the project specifications with a change control system

**Answer:** ([SHOW ANSWER](#))

**NEW QUESTION: 698**

A project manager has been assigned with initiating a large project to deliver complex equipment. Part of the project will be the result of a long research process, but once this is completed, the other part of the project must be incrementally delivered to the customer.

Which approach should the project manager choose for this project?

- A. Waterfall
- B. Agile
- C. Predictive
- D. Hybrid

**Answer:** B ([LEAVE A REPLY](#))

**NEW QUESTION: 699**

A new project manager joins a project in progress. The project manager is unclear about what environmental factors may impact effective information reporting to key stakeholders.

What should the project manager reference to understand these impacts?

- A. Stakeholder engagement plan
- B. Procurement management plan
- C. Communication management plan
- D. Risk management plan

**Answer:** C ([LEAVE A REPLY](#))

**NEW QUESTION: 700**

In which type of organizational structure are staff members grouped by specialty?

- A. Functional
- B. Projectized
- C. Matrix
- D. Balanced

**Answer:** A ([LEAVE A REPLY](#))

**NEW QUESTION: 701**

An experienced project manager is assigned to a project that could fail to meet its goals and objectives. What should the project manager do to decrease the likelihood of this happening?

- A. Actively manage stakeholder involvement.
- B. Review change control procedures.
- C. Manage quality
- D. Regularly update lessons learned communications.

**Answer:** ([SHOW ANSWER](#))

Section: Monitoring and Controlling

**NEW QUESTION: 702**

Which of the following is an output of the Information Distribution Process?

- A. Project calendar
- B. Communication management plan
- C. Requested changes
- D. Communication requirement plan

**Answer:** C ([LEAVE A REPLY](#))

**NEW QUESTION: 703**

The VP of marketing approaches you and requests that you change the visitor logon screen on the company's website to include a username with at least six characters. This is considered

- A. ongoing operations
- B. a project
- C. project initiation
- D. project execution

**Answer:** A ([LEAVE A REPLY](#))

Projects exist to create a unique product, service, or result. The logon screen in this question is not a unique product. A minor change has been requested, indicating this is an ongoing operation function. Some of the criteria for projects are that they are unique, temporary with definitive start and end dates, and considered complete when the project goals are achieved.

**NEW QUESTION: 704**

A team is experiencing difficulties and has decided to use a spike. Please click on the portion of the burndown chart that corresponds to the spike.

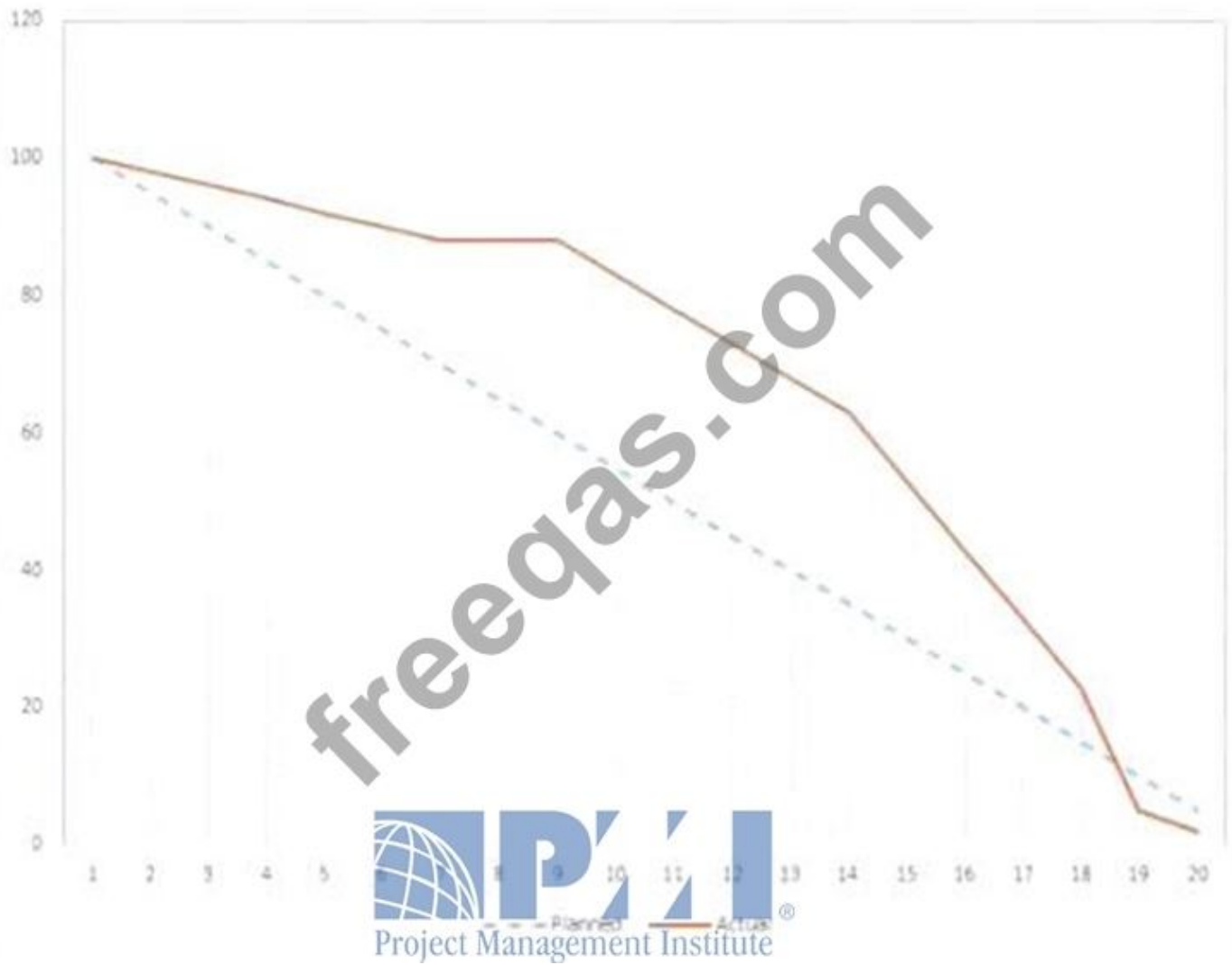

**Answer:**

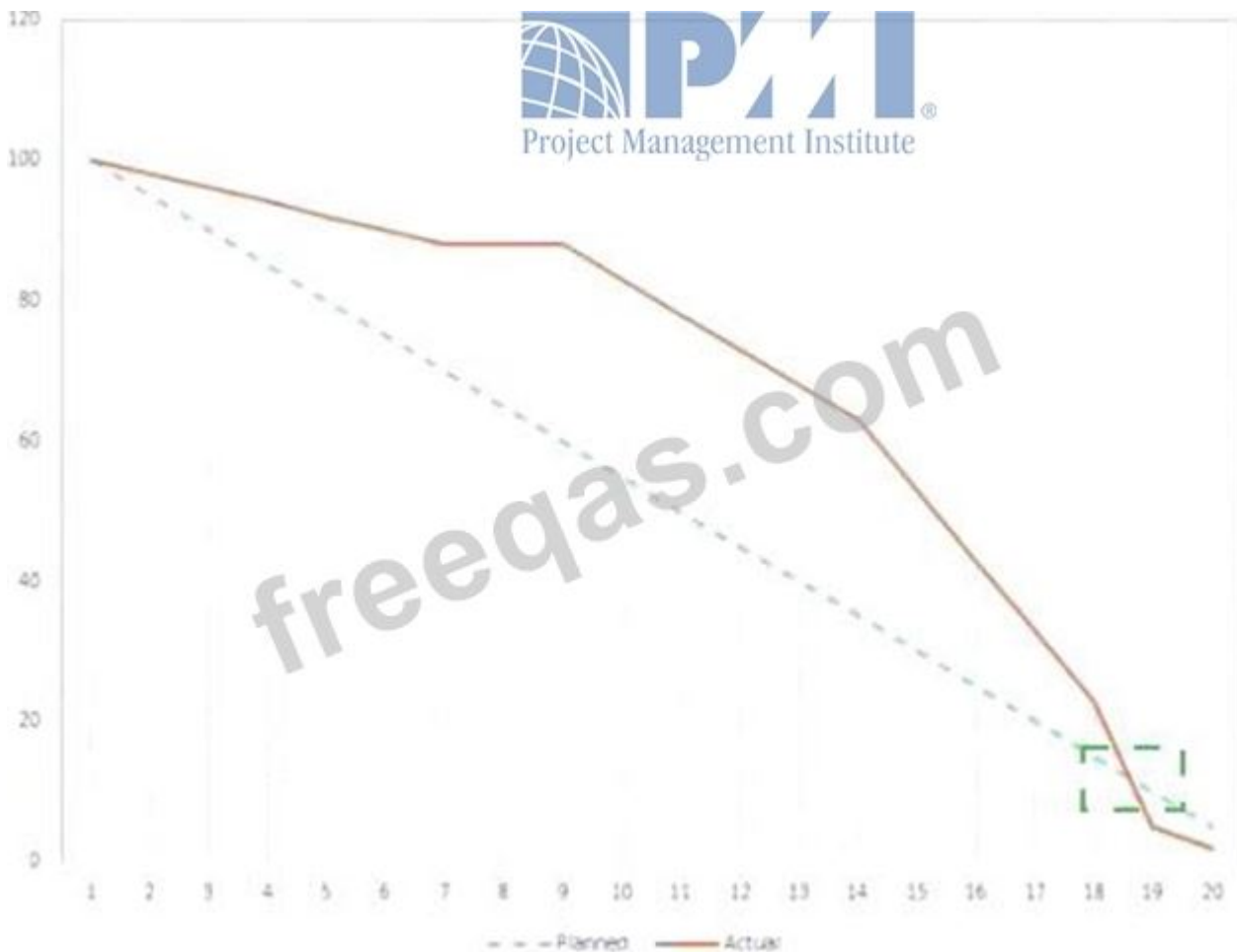

**NEW QUESTION: 705**

CORRECT TEXT

You have been recently hired to be a project manager at a bio-tech company to develop a new drug for the treatment of malignant melanoma. As part of feasibility study, your team has been evaluating the feasibility for such a drug using computer simulation. Your team has just completed one of the project phases by designing a potential chemical compound using a sophisticated computer model. You would like to have model reviewed prior to deciding whether to move to the next phase of the project. According to the PMI, these type of reviews are called:

- A. Milestones
- B. Deliverables
- C. Phase exists
- D. Target goals

**Answer: C (LEAVE A REPLY)**

**NEW QUESTION: 706**

An agile project team is looking to develop quality standards for a project How should the project manager coach the team?

- A. Insist that test-driven development is implemented along with the automated testing
- B. Determine the tools and techniques suitable for the project and ensure that testing is done early and continuously.

- C. Inform the team that user acceptance testing is required to ensure that the product owner accepts the solution
- D. Ensure that the definition of done (DoD) is provided when the product owner agrees that all acceptance criteria have been met for the user story

**Answer:** ([SHOW ANSWER](#))

**Valid PMP Dumps** shared by PrepPdf.com for Helping Passing PMP Exam! PrepPdf.com now offer the **newest PMP exam dumps**, the PrepPdf.com PMP exam **questions have been updated** and **answers have been corrected** get the **newest** PrepPdf.com PMP dumps with Test Engine here: <https://www.preppdf.com/PMI/PMP-prepaway-exam-dumps.html> (2045 Q&As Dumps, **40%OFF Special Discount: Exam-Tests**)

**NEW QUESTION: 707**

Project Managers have least power in which organization structure

- A. Matrix
- B. Functional
- C. Balanced
- D. Projectized

**Answer:** ([SHOW ANSWER](#))

**NEW QUESTION: 708**

During a project's execution phase, two key business stakeholders request additional requirements be made within the same timeframe. Due to limited project resources and budget, the project manager cannot fully meet the expectations of these stakeholders.

Which of the following techniques should the project manager adopt to obtain support from both of these key stakeholders?

- A. Smooth/accommodate
- B. Compromise/reconcile
- C. Withdraw/avoid
- D. Force/direct

**Answer:** B ([LEAVE A REPLY](#))

**NEW QUESTION: 709**

You are a Project Manager who is involved in the procurement of \$2,000,000 of infrastructure equipment.

As negotiations begin between your company and the vendor, you realize that your brother works for this company but in a different department. What is your professional and social responsibility?

- A. Because he works in a different department, you can remain on the project

- B. Remain on the project, but remove yourself from the negotiations
- C. Remove yourself from the project
- D. Remain on the project, but help another Project Manager negotiate the contract

**Answer: C (LEAVE A REPLY)**

Section: Mix Questions

**NEW QUESTION: 710**

What type of project structure is a hierarchically organized depiction of the resources by type?

- A. Organizational breakdown structure (OBS)
- B. Resource breakdown structure (RBS)
- C. Work breakdown structure (WBS)
- D. Project breakdown structure (PBS)

**Answer: B (LEAVE A REPLY)**

Section: Initiation

**NEW QUESTION: 711**

The process of conferring with others to come to terms or reach an agreement is called\_\_\_\_\_

- A. Win-win
- B. Negotiation
- C. Getting to "yes"
- D. Confrontation

**Answer: B (LEAVE A REPLY)**

Explanation/Reference:

Explanation:

Negotiation if done well increases the probability of project success and involves conferring with others of shared or opposed interests with a view toward compromise. Negotiating is required to achieve mutually acceptable agreements between parties.

**NEW QUESTION: 712**

An employee approaches you and asks to tell you something in confidence. He advises you that he has been performing illegal activities within the company for the last year. He is feeling guilty about it and is telling you in order to receive advice as to what he should do. What should you do?

- A. Ask for full details.
- B. Confirm that the activity is really illegal.
- C. Inform your manager of the illegal activity.
- D. Tell the employee to inform his boss.

**Answer: C (LEAVE A REPLY)**

**NEW QUESTION: 713**

Which approach to creating a WBS is often used for projects that involve new systems or approaches for doing a job?

- A. Template approach
- B. Bottom-up approach
- C. analogy approach
- D. Top-Down approach

**Answer: B (LEAVE A REPLY)**

We decompose the scope statement to create a WBS. We start with a high level and drill down to lower levels. Especially in this situation when its a new system, we do not know the details hence start with the top. [#2] Well, first of all, we know C & A are eliminated for use on a "new systems" project. However, there is a piece of information missing from the question which would make it difficult to choose between B & D. Generally, projects with less precedent (ie R&D or new products) are characterized by greater risk, particularly if they are also associated with high cost. A definitive (bottom-up) estimate could serve to mitigate the risk in that case because it is more accurate. However, it is also a more expensive and time-consuming type of estimate so what's missing from the question is whether or not you have the luxury of the time & money to invest in this approach. Remember that just because it is a "new systems" project doesn't mean a bottom-up estimate is precluded, because you could always approach it with the Moving Wave technique described in Kerzner, meaning that you take the first phase of the project down to WBS Level 4 and leave the second phase only roughly defined down to Level 2 until you've advanced far enough to be able to define it. However, since the magnitude of the project (in time & budget) is not given in this question, I would go with answer B. [#3] Top down approach is used only if you have enough historical information on the Project. in this case it is not true. Hence it would be appropriate to use Bottom up approach so, answer is B.

### NEW QUESTION: 714

Which of the following best describes the following organizational structure? Exhibit:



- A. Balanced Matrix Org
- B. Projectized Org
- C. Strong Matrix Org
- D. Weak Matrix Org
- E. Functional Org

**Answer: B (LEAVE A REPLY)**

**NEW QUESTION: 715**

A project manager joins an ongoing firm fixed price (FFP) project. The project manager discovers that there is no lessons learned repository and that, to date, no retrospective meetings were held. The existing project budget does not cover lessons learned activities and, so far, this has not created any issues.

What should the project manager do?

- A. Proceed with the project plan, and record this risk in the risk register.
- B. Conduct the minimum amount of lessons learned activities in the team's spare time.
- C. Submit a change request to allocate a part of the budget for lessons learned activities.
- D. Complete lessons learned activities using management reserve funds,

**Answer: C ([LEAVE A REPLY](#))**

**NEW QUESTION: 716**

An organization is producing a product using a hybrid approach with several phases. Some of the phases are planned to be executed in predictive and some in agile. During the agile phase, the project manager notices that the team members sometimes unknowingly work on the same task.

What should the project manager do?

- A. Communicate the task assignments to the team members in a clear manner.
- B. Confirm that the agile coach has made the task assignments clear.
- C. Verify that the product owner has made the task assignments clear.
- D. Verify that the team members have made the task assignments clear.

**Answer: D ([LEAVE A REPLY](#))**

**NEW QUESTION: 717**

Project schedule development is an iterative process. If the start and finish dates are not realistic, the project probably will not finish as planned. You are working with your team to define how to manage schedule changes. You documented your decisions in which of the following?

- A. Schedule change control procedures
- B. Schedule management plan
- C. Schedule risk plan
- D. Service-level agreement

**Answer: B ([LEAVE A REPLY](#))**

Explanation/Reference:

Explanation:

The schedule management plan is part of the overall project management plan and defines, among other things, how schedule changes will be managed. Whether it is formal or informal, highly detailed or broadly framed, it generally is based on specific project needs.

**NEW QUESTION: 718**

You are in the process of directing the performance of the planned project activities and managing the various technical and organizational interfaces that exist within your project. All the following are actions that you should perform in this stage except:

- A. Establish and manage communication channel
- B. Collect and document lessons learned
- C. Subdivide the major project deliverable into smaller, more manageable work packages
- D. Manage sellers
- E. Manage risks and implement risk response activities

**Answer: C ([LEAVE A REPLY](#))**

#### **NEW QUESTION: 719**

Ensuring that projects and programs are reviewed to prioritize resource allocation is a focus of which of the following?

- A. Project management
- B. Program management
- C. Relationship management
- D. Portfolio management

**Answer: D ([LEAVE A REPLY](#))**

#### **NEW QUESTION: 720**

The project team members have gotten together at the end of the project to review what happened on the project, discussing what went well and what didn't. They undertake this discussion for the sake of future project so that they can repeat the things that worked on the project and eliminate repeating the things that didn't work so well. This is known as what?

- A. Contract audit
- B. Lessons learned
- C. Closing the project
- D. Contract Closure

**Answer: B ([LEAVE A REPLY](#))**

#### **NEW QUESTION: 721**

Which of the following is NOT a tool or technique of Qualitative Risk Analysis?

- A. Probability and impact matrix
- B. Risk urgency assessment
- C. Risk categorization
- D. Expected monetary value analysis

**Answer: ([SHOW ANSWER](#))**

Qualitative Risk Analysis is all about figuring out prioritizing each risk, and figuring out its probability and impact. It's an important part of risk planning. But it's not about coming up with specific numbers! That's what Quantitative Risk Analysis is for - and EMV analysis is part of Quantitative (not Qualitative) analysis, because it's where you assign numeric values to risks.

**Valid PMP Dumps** shared by PrepPdf.com for Helping Passing PMP Exam! PrepPdf.com now offer the **newest PMP exam dumps**, the PrepPdf.com PMP exam **questions have been updated** and **answers have been corrected** get the **newest** PrepPdf.com PMP dumps with Test Engine here: <https://www.preppdf.com/PMI/PMP-prepaway-exam-dumps.html> (2045 Q&As Dumps, **40%OFF Special Discount: Exam-Tests**)

**NEW QUESTION: 722**

A project manager has been assigned to a project where collaboration with the business is a critical key factor.

The project manager is not sure about which approach to use. A senior project manager has been assigned to help the project manager.

What advice should the senior project manager provide?

- A. Establish a project management methodology that requires the customer to provide daily updates to the team.
- B. Suggest using an agile approach since customer and team collaboration is critical for project success.
- C. Work with the project manager to develop a new approach that will bring benefits to the project.
- D. Provide a project management template for the project manager to follow as a guide.

**Answer: B (LEAVE A REPLY)**

**NEW QUESTION: 723**

A project's earned value (EV) report indicates that an activity's cost variance (CV) is -50,000 and its schedule variance (SV) is 1,000. What is the status value of this activity?

- A. On schedule and within budget
- B. Ahead of schedule and over budget
- C. Behind schedule and over budget
- D. Behind schedule and within budget

**Answer: D (LEAVE A REPLY)**

**NEW QUESTION: 724**

A senior manager asks a team member for a quick update on the project's progress. The team member redirects the senior manager to the project manager to ensure that the information being relayed is accurate and appropriate for this manager to receive. What document dictated this team member's action?

- A. Communications management plan
- B. Stakeholder register
- C. previous week's meeting minutes

D. Responsible, accountable, consult, and inform (RACI) matrix

**Answer: A ([LEAVE A REPLY](#))**

**NEW QUESTION: 725**

Which process involves documenting the actions necessary to define, prepare, integrate, and coordinate all subsidiary plans?

- A. Collect Requirements
- B. Direct and Manage Project Execution
- C. Monitor and Control Project Work
- D. Develop Project Management Plan

**Answer: D ([LEAVE A REPLY](#))**

Section: Planning

**NEW QUESTION: 726**

A project manager develops a business case during project initiation. What areas should the project manager consider when developing the business case?

- A. Expected resource performance and cost-benefit analysis
- B. Expected resource performance and the project's contribution to the strategic portfolio objectives
- C. Business benefits provided by project deliverables and portfolio analysis
- D. Business benefits provided by project deliverables and the organizational strategy

**Answer: D ([LEAVE A REPLY](#))**

Section: Initiation

**NEW QUESTION: 727**

Decomposition of project work involves all of the following EXCEPT:

- A. Assigning identification codes to WBS components
- B. Structuring and organizing the WBS
- C. Presenting hierarchal depiction of project organization so that work packages can be related to performing organizational units
- D. Decomposition upper WBS level into lower level detailed components
- E. Identifying deliverables

**Answer: C ([LEAVE A REPLY](#))**

**NEW QUESTION: 728**

Information retrieval systems, information distribution methods, and communication skills are tools/ techniques of which of the following processes?

- A. Communications planning
- B. Information distribution
- C. Performance reporting
- D. Manage stakeholders

**Answer: B ([LEAVE A REPLY](#))**

**NEW QUESTION: 729**

On any project, quality should usually be of \_\_\_\_\_?

- A. Lower priority than cost and schedule.
- B. Higher priority than cost and schedule.
- C. Equal priority with cost and schedule.
- D. Equal priority with schedule, but higher priority than cost.
- E. Equal priority with cost, but higher priority than schedule.

**Answer: C ([LEAVE A REPLY](#))**

**NEW QUESTION: 730**

You are using earned value progress reporting for your current project in an effort to teach your software developers the benefits of earned value. You plan to display project results on the cafeteria bulletin board so that the team knows how the project is progressing.

PV = \$2,200

EV = \$2,000

AC = \$2,500

BAC = \$10,000

The CV for this project is \_\_\_\_\_

- A. 300
- B. -\$300
- C. 500
- D. -\$500

**Answer: ([SHOW ANSWER](#))**

Section: Mix Questions

Explanation:

CV is calculated as EV - AC (in this case, \$2,000 - \$2,500). A negative CV means that accomplishing work on the project is costing more than was budgeted.

**NEW QUESTION: 731**

A project manager is assigned to a dental equipment development project that is in the middle of its design phase. After reviewing the project prototype, it is identified that a couple of requirements specifications are missing.

Which action should the project manager take next?

- A. Ask the team to wait until they are able to update the requirements specifications.
- B. Meet with the development team to review and assess the requirements specifications.
- C. Prepare a change request for the change control board (CCB) to remove the missing requirements specifications.
- D. Discuss with the team and build a workaround plan to immediately deliver the pending requirements specifications.

**Answer:** ([SHOW ANSWER](#))

**NEW QUESTION: 732**

A project manager has been assigned to manage multiple agile project teams. The project manager wants to empower the teams and make them self-organizing.

What should the project manager do to create a positive environment?

- A.** Help the teams in establishing and adhering to their ground rules and revisit after regular intervals.
- B.** Establish the team ground rules and share them with the team for strict adherence.
- C.** Copy the ground rules established by another project and provide them to the teams.
- D.** Extract the organization's policies and processes, customize them, and give them to the teams to adhere to.

**Answer:** **A** ([LEAVE A REPLY](#))

**NEW QUESTION: 733**

You've been hired as a manager for the adjustments department of a nationwide bank based in your city. The adjustments department is responsible for making corrections to customer accounts. This is a large department, with several smaller sections that deal with specific accounts, such as personal checking or commercial checking. You've received your first set of management reports and can't make heads or tails of the information. Each section appears to use a different methodology to audit their work and record the data for the management report. You request a project manager from the PMO to come down and get started right away on a project to streamline this process and make the data and reports consistent. This project came about as a result of which of the following?

- A.** Customer request
- B.** Technological advance
- C.** Business need
- D.** Legal requirement

**Answer:** **C** ([LEAVE A REPLY](#))

This came about because of a business need. Staff members were spending unproductive hours producing information for the management report that wasn't consistent or meaningful.

**NEW QUESTION: 734**

In a project with a multigenerational team, some resources are underperforming due to differing viewpoints.

This may cause project delays.

What should the project manager do?

- A.** Use the force/direct technique.
- B.** Find new, more cooperative team members.
- C.** Define the communications management plan for the team
- D.** Use the collaborate/problem solve technique.

**Answer: D ([LEAVE A REPLY](#))**

**NEW QUESTION: 735**

An organization's objectives require the reduction of costs associated with future failures. What should the project manager do when budgeting cost?

- A. Increase the budget to prevent poor quality.
- B. Increase the budget for project waste disposal.
- C. Increase the budget, then evaluate, measure, and test the products.
- D. Increase the budget for nonconformance resolution.

**Answer: C ([LEAVE A REPLY](#))**

Section: Planning

**NEW QUESTION: 736**

Which of the following contracts should you use for projects that have a degree of uncertainty and require a large investment early in the project life cycle?

- A. Cost reimbursable
- B. T&M
- C. Fixed price
- D. Lump sum

**Answer: A ([LEAVE A REPLY](#))**

Cost-reimbursable contracts are used when the degree of uncertainty is high and when the project requires a large investment prior to completion of the project.

**Valid PMP Dumps** shared by PrepPdf.com for Helping Passing PMP Exam! PrepPdf.com now offer the **newest PMP exam dumps**, the PrepPdf.com PMP exam **questions have been updated** and **answers have been corrected** get the **newest** PrepPdf.com PMP dumps with Test Engine here: <https://www.preppdf.com/PMI/PMP-prepaway-exam-dumps.html> (2045 Q&As Dumps, **40%OFF Special Discount: Exam-Tests**)

**NEW QUESTION: 737**

A project manager notices that the project team is unlikely to complete the development of a system on time before the testing start date, which was based on the technical complexity of the project. What should the project manager do before communicating with the client during the regular project progress meeting?

- A. Tell the client about the chance for the potential delay.
- B. Work with the project team to evaluate the potential delay.
- C. Ask the project sponsor to inform the client in the next update.
- D. Do not disclose the likelihood of a delay as it is yet to happen.

**Answer: B ([LEAVE A REPLY](#))**

**NEW QUESTION: 738**

For this past six months, a project manager has struggled with defining a project's scope. The project team has been working with the customer to make small adjustments to the requirements, but is taking longer than expected.

What should the project manager do to complete the scope?

- A. Conduct a data-gathering meeting to review the collected requirements.
- B. Internally finalize the requirements with the team, and share them with the client.
- C. Facilitate a workshop to agree on the final requirements.
- D. Provide training to the team on collecting requirements best practices.

**Answer: (SHOW ANSWER)**

Section: Planning

**NEW QUESTION: 739**

You are a project manager managing a global project. You have stakeholders located in various parts of the globe. Data-gathering is an important technique in the Identify Stakeholders process. Due to the nature of the project, you also have large volumes of information that needed to be collected from the project stakeholders.

Which of the following is an important tool available for gathering and organizing stakeholders' information?

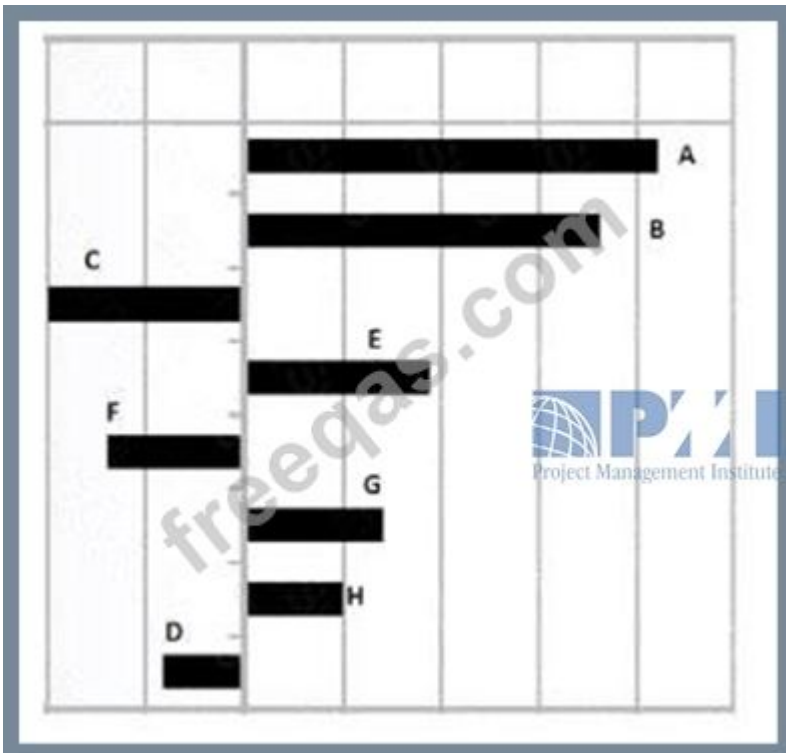

- A. Fishbone diagrams
- B. Control charts
- C. Focus groups
- D. Questionnaires and surveys

**Answer: D (LEAVE A REPLY)**

**NEW QUESTION: 740**

A key project stakeholder who was a big supporter and motivator for the project team is leaving the organization. The project team is experiencing low morale and poor teamwork. What should the project manager do to improve morale?

- A. Forge consensus through team participation.
- B. Identify the wants and aspirations of the team.
- C. Set goals and push the team to achieve the goals.
- D. Build team connections and emotional bonds.

**Answer: B** ([LEAVE A REPLY](#))

**NEW QUESTION: 741**

You are in the process of directing the performance of a planned project activities and managing various technical and organizational interfaces that exist within your project. All of the following are required inputs EXCEPT:

- A. Project management plan
- B. Approved corrective actions, approved preventive actions
- C. Work performance information
- D. Validated defect repair, administrative closure procedure
- E. Approved change requests, approved defect repair

**Answer: C** ([LEAVE A REPLY](#))

**NEW QUESTION: 742**

A project manager is performing a set of processes in the Initiating Process Group. Often the first task performed by the project manager while initiating the project is:

- A. Conduct benefits analysis to validate project alignment
- B. Identify key deliverables based on business requirements
- C. Participate in the development of the project charter
- D. Perform a project assessment to evaluate the feasibility of the project.

**Answer: D** ([LEAVE A REPLY](#))

**NEW QUESTION: 743**

According to a new product development process, the marketing department will begin adding business and user requirements directly into agile project documents. Drag the product information on the left to the correct documents on the right.

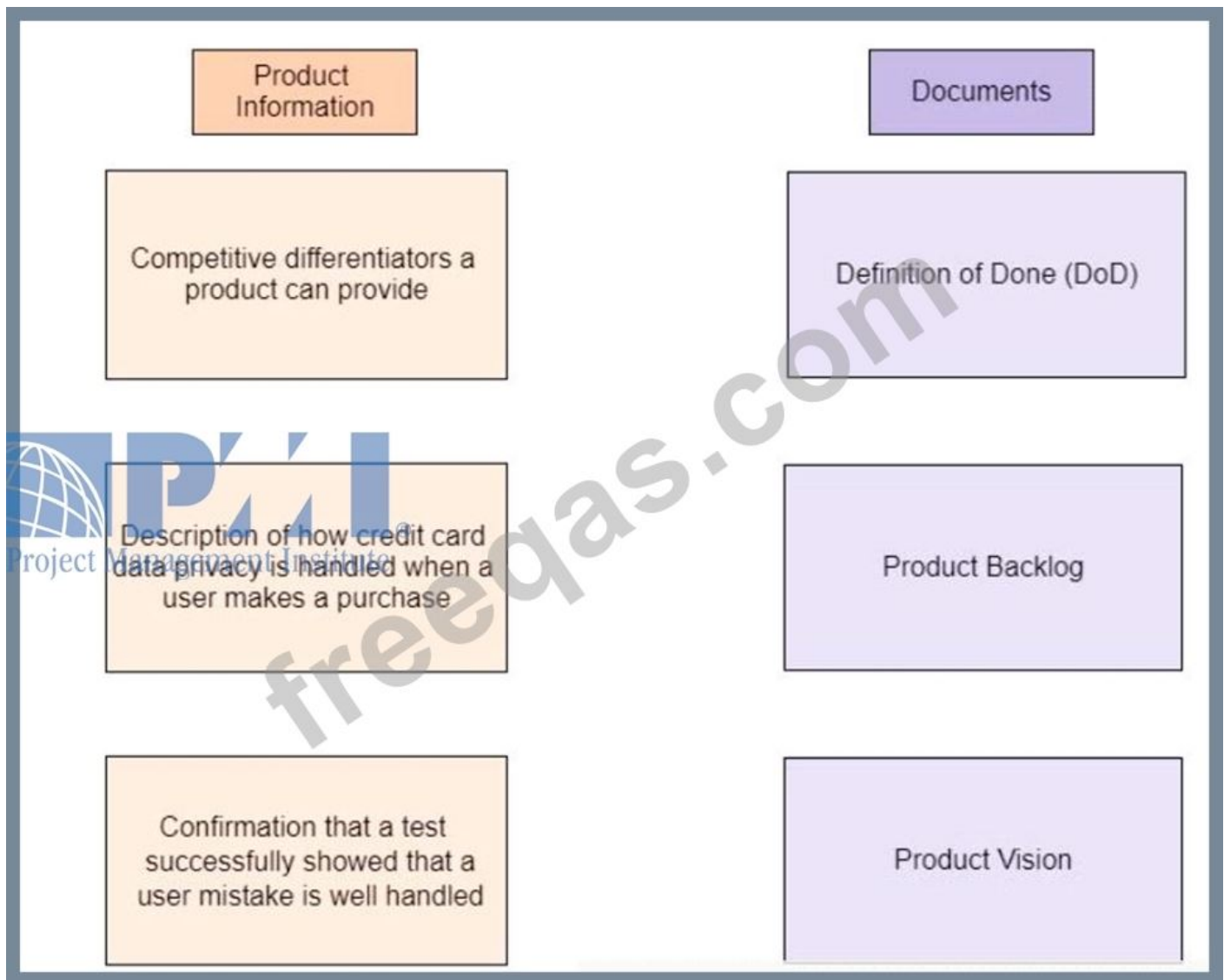

**Answer:**

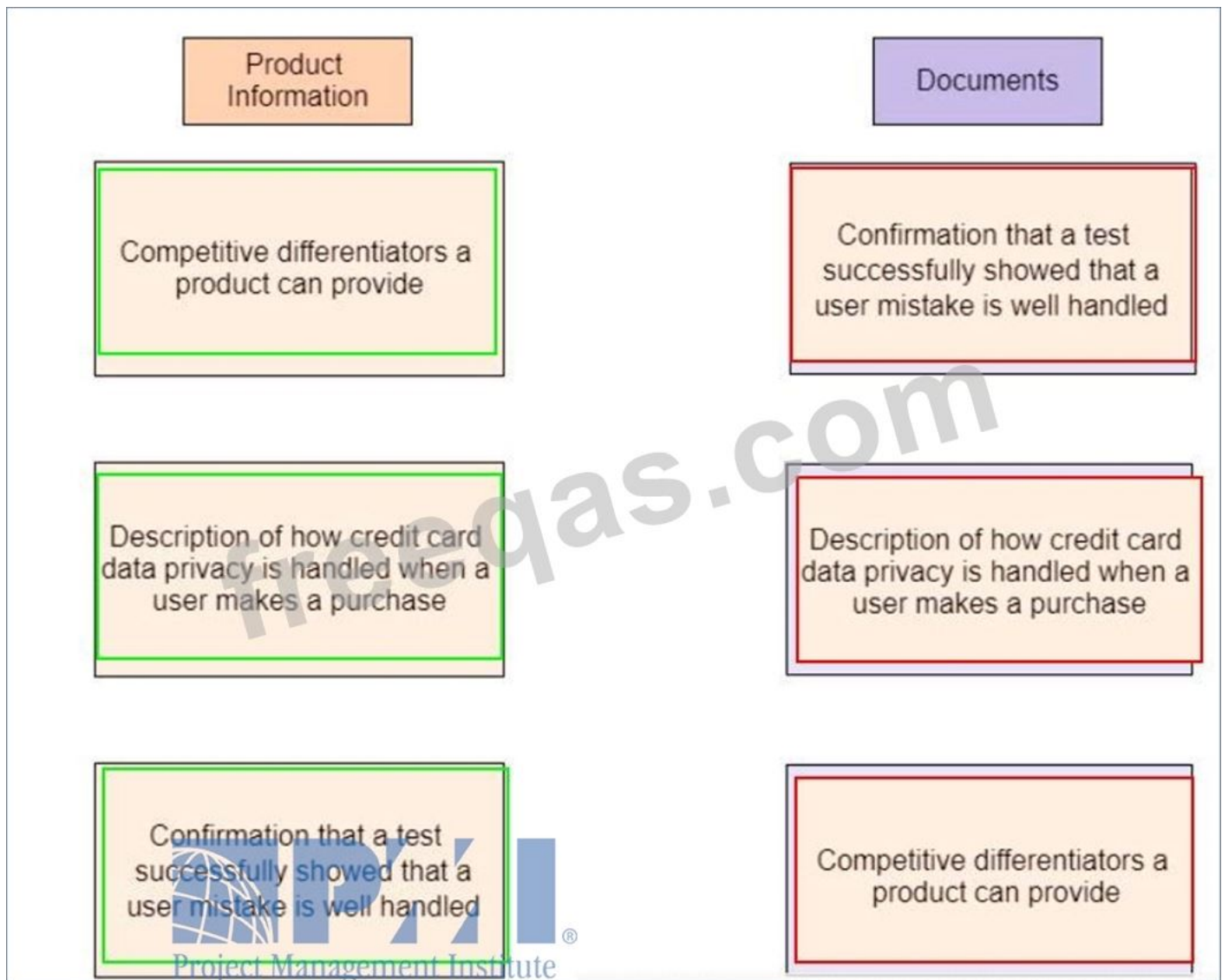

**NEW QUESTION: 744**

Which of the following best describes the following organizational structure? Exhibit:

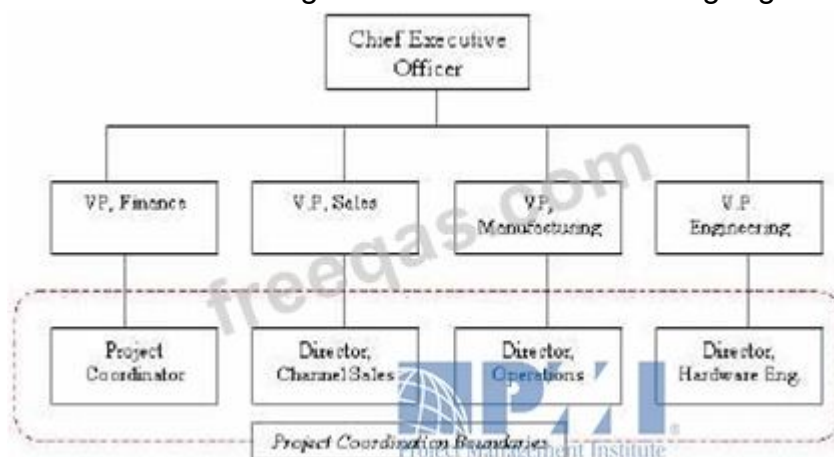

- A. Functional Org
- B. Projectized Org
- C. Weak matrix Org
- D. Balanced matrix Org
- E. Strong matrix Org

**Answer: C ([LEAVE A REPLY](#))**

**NEW QUESTION: 745**

A customer calls the project manager to express concern about a project team member who has been making changes within the live environment without approval. The team member mentioned that the customer called and asked them to make the changes.

What should the project manager do next?

- A.** Organize a meeting to mediate the relationship between the customer and the team member to ensure no feelings are hurt.
- B.** Ask the customer to email all requests directly to you and you will ensure they are actioned by the correct team member.
- C.** Reinforce the value of documenting and approving all change requests and ask the customer to issue these through the agreed channels.
- D.** Explain to the customer that the team member was just trying to help and the changes can be reverted if necessary.

**Answer: ([SHOW ANSWER](#))**

**NEW QUESTION: 746**

Which of the following describes the contents of a staffing management plan?

- A.** Sponsor, Organizational Chart, Scope Verification Plan, and Schedule
- B.** Organizational Chart, Training needs, Estimated Labor Cost, and Release Criteria
- C.** RACI Matrix, Organizational Chart, Performance Improvement Plan, and Budget
- D.** Resource Histogram, Training Needs, Recognition and Rewards, and Release Criteria

**Answer: D ([LEAVE A REPLY](#))**

The Staffing Management Plan always includes a Resource Histogram, so that should be your first clue about which one of these answers is right. The Resource Histogram shows what kind of resource is needed through each week of your project and how many staff members you need. When planning out your staffing needs, you need take into account the training it will take to get them up to speed as well as the kinds of incentives you are going to offer for a job well done. Release criteria are important too, but they might not be familiar to you if you don't work in a consulting organization. You need to think about what each staff member needs to get done before they are released to work on other projects.

**NEW QUESTION: 747**

Which Process Group typically consumes the bulk of a project's budget?

- A.** Monitoring and Controlling
- B.** Executing
- C.** Initiating
- D.** Planning

**Answer: B ([LEAVE A REPLY](#))**

**NEW QUESTION: 748**

A project needs to purchase a specific piece of equipment, as stated in the project documents and approved by the project sponsor. The procurement division is questioning the need to buy the specific brand of equipment and has suggested buying a cheaper alternative instead.

What should the project manager have done earlier in the project to ensure the purchase of the specific equipment?

- A. Included a procurement division member on the project team
- B. Communicated the project management plan to the procurement division
- C. Communicated the project charter to the procurement division
- D. Reminded the project sponsor about the procurement division's reputation

**Answer: C ([LEAVE A REPLY](#))**

**NEW QUESTION: 749**

What happens if the level of conformance directly increases as a consequence of new processes?

- A. Required monitoring cost should stay the same.
- B. Required monitoring cost should be more predictable.
- C. Required monitoring cost should increase.
- D. Required monitoring cost should decrease.

**Answer: ([SHOW ANSWER](#))**

**NEW QUESTION: 750**

A structured tool, usually industry or activity specific, used to verify that a set of required steps has been performed is called:

- A. Trend analysis
- B. Check list
- C. Pareto diagram
- D. Quality Policy

**Answer: B ([LEAVE A REPLY](#))**

**NEW QUESTION: 751**

A company is producing a children's movie and wants a toy company to create action figures based on the new movie. The project sponsor is concerned about possible cost implications.

Which course of action should the project manager take?

- A. Create a joint venture with a toy company
- B. Abandon the plan to create action figure toys to mitigate costs
- C. Expand operations to manufacture the toys internally.
- D. Hire a toy company to design and manufacture the toys

**Answer: A ([LEAVE A REPLY](#))**

**Valid PMP Dumps** shared by PrepPdf.com for Helping Passing PMP Exam! PrepPdf.com now offer the **newest PMP exam dumps**, the PrepPdf.com PMP exam **questions have been updated** and **answers have been corrected** get the **newest** PrepPdf.com PMP dumps with Test Engine here: <https://www.preppdf.com/PMI/PMP-prepaway-exam-dumps.html> (2045 Q&As Dumps, **40%OFF Special Discount: Exam-Tests**)

**NEW QUESTION: 752**

Using the data shown: TARGET COST: 12,000, TARGET FEE: 1000, SHARE RATION: 80/20 and PRICE CEILING: 14,000. The point of total assumption occurs at a cost of:

- A. 12,250
- B. 12,750
- C. 13,250
- D. 14,000

**Answer: C (LEAVE A REPLY)**

The Point of Total Assumption (PTA) is related to Fixed Price Incentive contracts. It is the point at which seller assumes 100% of the cost overruns (just before the ceiling price is reached). At this point, Actual Cost plus Actual Fee equals to the Ceiling Price. It is the point where a FPIF contract turns into a Firm Fixed Price contract, because at this point the profit the seller will make equals what he/she has already spent on it. So, the only way to make money is to continue with the project.  $PTA = Target\ Cost + (Ceiling\ Price - Target\ Price) / Buyer's\ Share$   
Target Cost = 12000  
Target Fee = 1000  
Target Price = 12000 + 1000 = 13000  
Ceiling Price = 14000  
Buyer's ratio = 80%  
 $PTA = 12000 + (14000 - 13000) / 0.8 = 13250$ . So, answer is (C). [Check this way...] When Actual Cost = 13250, cost overrun is 13250 - 12000 = 1250. So Incentive (actually penalty) = -1250 \* 0.20 = -250 and Net Fee = 1000 - 250 = 750. Hence, Actual Price = 13250 + 750 = 14000. This is also equal to Ceiling Price.

**NEW QUESTION: 753**

What tool should the project manager use to demonstrate to the customer that the final product meets the business needs?

- A. Work breakdown structure
- B. Project scope statement
- C. Project management plan
- D. Requirements traceability matrix

**Answer: D (LEAVE A REPLY)**

**NEW QUESTION: 754**

In your project, there have been several changes in the cost and schedule estimates and the original estimating assumptions are no longer valid. What is the Estimate at Complete for your project?

BAC = \$ 300,000 AC = \$ 100,000 EV = \$ 150,000 CPI = \$ 1.2 ETC = \$ 120,000

- A. \$ 300,000
- B. \$ 250,000
- C. \$ 280,000
- D. \$ 220,000

Answer: ([SHOW ANSWER](#))

**NEW QUESTION: 755**

Assume you are preparing your procurement management plan. A useful tool and technique is to \_\_\_\_\_

- A. Have a meeting
- B. Use your risk register
- C. Review the requirements document
- D. Use your stakeholder register

Answer: ([SHOW ANSWER](#))

Explanation/Reference:

Explanation:

Meetings are another tool and technique in plan procurement management. They are held as research alone may not provide specific information for a procurement strategy without additional information exchange with potential bidders. Through collaborating with potential bidders the organization purchasing the material or service may benefit. Suppliers may benefit to influence a mutually beneficial approach or product.

**NEW QUESTION: 756**

In a functional organization, a product analyst is assigned to a short-duration application development effort. The analyst expresses concerns about the task and asks the project manager to provide the support of a peer with expertise in this domain. What should the project manager do?

- A. Recognize the analyst's concerns and reassign the task to another team member
- B. Enroll the analyst in a capacity-building program and keep this analyst assigned to the task
- C. Ask the analyst to use skills to develop the tool, then move development to another team member
- D. Make sure the analyst has regular pairing meetings with the other team member throughout task execution

Answer: D ([LEAVE A REPLY](#))

**NEW QUESTION: 757**

You are managing the construction of a highly sophisticated data center in Port Moresby, Papua, New Guinea.

Although this location offers significant economic advantages, the threat of typhoons has caused you to create a backup plan to operate in Manila in case the center is flooded. This plan is an example of what type of risk response?

- A. Passive avoidance
- B. Mitigation
- C. Active acceptance
- D. Deflection

**Answer: C (LEAVE A REPLY)**

Section: Mix Questions

Explanation:

Active acceptance means not only accepting the consequences of a risk, but also establishing a plan for dealing with the risk, should it occur. Organizations typically establish a contingency plan funded by a contingency reserve (of time, money, or resources) to handle known, or even sometimes potential unknown, threats or opportunities.

PMI, PMBOK Guide, 2013, 345

### **NEW QUESTION: 758**

The purpose of the Taguchi method is to\_\_\_\_\_

- A. Manage the flow of material for better visibility and control
- B. Use statistical techniques to compute a "loss function" to determine the cost of producing products that fail to achieve a target value
- C. Design, group, and manage production operations as self-contained flexible cells capable of start-to-finish processing of a family of items
- D. Regulate coordination and communication among process stages

**Answer: B (LEAVE A REPLY)**

Section: Mix Questions

Explanation:

The Taguchi method is used to estimate the loss associated with controlling or failing to control process variability. It is based on the principle that by carefully selecting design parameters to produce robust designs, an organization can produce products that are more forgiving and tolerant. The tool helps determine the value or break-even point of improving a process to reduce variability.

### **NEW QUESTION: 759**

At the end of a meeting a functional manager takes the project manager aside to raise some concerns on behalf of a project team member who is unclear about their role and responsibilities for the project What should the project manager do in this situation?

- A. Tell the functional manager and the project team member to review the project charter
- B. Develop a work plan for the project team member with the help of the resource manager
- C. Advise the functional manager and the project team member to review the resource management plan
- D. Ask the functional manager to create a specific responsible, accountable, consult, and inform (RACI) chart for the team member

**Answer: C (LEAVE A REPLY)**

**NEW QUESTION: 760**

A project manager identifies a risk for a complex module in a project. Before executing work on this module, a technical specialist suggests adopting a proven technology rather than using a new, experimental technology.

The project manager accepts this suggestion.

What risk response strategy did the project manager use?

- A. Transfer
- B. Avoid
- C. Mitigate
- D. Share

**Answer: C ([LEAVE A REPLY](#))**

**NEW QUESTION: 761**

To please the customer, a project team member delivers a requirement which is uncontrolled.

This is not part of the plan. This describes:

- A. scope creep.
- B. a change request.
- C. work performance information.
- D. deliverables.

**Answer: A ([LEAVE A REPLY](#))**

Section: Executing

Explanation/Reference:

**NEW QUESTION: 762**

All of the following statements regarding the risk breakdown structure (RBS) is true EXCEPT:

- A. The lowest level of risk breakdown structure can be used as a risk checklist
- B. None of the choices are correct
- C. The risk breakdown structure represents a hieratically organized representation of identified project risks arranged by risk categories
- D. The RBS describes the list of identified risks, list of potential responses, and root causes of risks
- E. The RBS lists the categories and sub-categories within which risks may arise

**Answer: D ([LEAVE A REPLY](#))**

**NEW QUESTION: 763**

Plan Risk Management is the process of defining how to:

- A. Communicate identified risks to the project stakeholders.
- B. Conduct risk management activities for a project.
- C. Analyze the impact a specific risk may have on the project.
- D. Address unexpected risks that may occur during a project.

**Answer: (SHOW ANSWER)**

Section: Initiation

**NEW QUESTION: 764**

During a project's execution phase, the sponsor requests a feature that was not in the original plan. The project team agrees that implementing the feature would not impact the schedule. How should the project manager proceed?

- A. Reject the change, because cost impacts were not considered.
- B. Review the change management plan, and record the request in the change log.
- C. Review the requirements traceability matrix to identify why the feature was not included in the scope.
- D. Allow the project team to implement the change, and inform the sponsor when the change is completed.

**Answer: B (LEAVE A REPLY)**

**NEW QUESTION: 765**

Which of the following are three inputs to the risk register?

- A. Risk register updates, stakeholder register, and quality management plan
- B. Communication management plan, enterprise environmental factors, and activity duration estimates
- C. Risk management plan, activity cost estimates, and project documents
- D. Project scope statement, organizational process assets, and scope baseline

**Answer: C (LEAVE A REPLY)**

Section: Planning

**NEW QUESTION: 766**

What is the term assigned to products or services having the same functional use but different technical characteristics?

- A. Scope
- B. Quality
- C. Specification
- D. Grade

**Answer: D (LEAVE A REPLY)**

Section: Monitoring and Controlling

**Valid PMP Dumps** shared by PrepPdf.com for Helping Passing PMP Exam! PrepPdf.com now offer the **newest PMP exam dumps**, the PrepPdf.com PMP exam **questions have been updated** and **answers have been corrected** get the **newest** PrepPdf.com PMP dumps with

**NEW QUESTION: 767**

Members of a project team are based in two countries. Experienced resources work together at company headquarters in country A, while the remaining resources who deliver the project work, are located in the client's office in country B. The project manager is located in the client's office most of the time. Last month, the experienced resources discovered several unacceptable issues, and expressed concern that the project manager is unable to fairly evaluate all efforts. This causes the experienced resources' productivity and morale to decline. What should the project manager do?

- A. Ask the experienced resources to recommend solutions to the issues
- B. Review individual achievements, and share them more frequently with the entire project team.
- C. Spend more time with the experienced resources to better support them
- D. Review personal goals with the experienced resources, and realign them with project needs and execution

**Answer: B** ([LEAVE A REPLY](#))

**NEW QUESTION: 768**

What does a CPI value greater than 1.0 indicate?

- A. Cost right at the estimated value
- B. Cost over the estimated value
- C. Cost right at the actual value
- D. Cost under the estimated value

**Answer: (**[SHOW ANSWER](#)**)**

**NEW QUESTION: 769**

A project manager is managing two integrated projects in a program. A key integration point is misaligned, which has resulted in delays. One of the team's integration leads is a subject matter expert (SME) in this integration area. The other team's integration lead is not a SME but is more senior and has worked on the project longer. Both team leads are blaming each other. What should the project manager do first to resolve this situation?

- A. Assign the resolution of this issue to the integration lead who is a SME
- B. Escalate the issue to the program architect who developed the integration plan
- C. Assign the resolution of the issue to the senior integration lead who has worked on the project longer
- D. Meet with both integration leads to understand the root cause and determine a resolution

**Answer: (**[SHOW ANSWER](#)**)**

**NEW QUESTION: 770**

Which of the following statements correctly characterizes pull communication?

- A. It includes letters, memos, reports, emails, and faxes.
- B. It is primarily used when the volume of information to be transferred is minimal.
- C. It is the most efficient way to ensure a common understanding among all participants.
- D. It requires recipients to access communication content at their own discretion.

**Answer: D (LEAVE A REPLY)**

#### **NEW QUESTION: 771**

You are just leaving a meeting, during which you have been assigned as the project manager in a project to build a substation, which is part of a major electric power distribution system. The decision to run the project has been made before your assignment and without your involvement. Some basic decisions on deliverables, staffing, budgeting and on the completion date have also already been made. What should you do first?

- A. Create a Project schedule for your project which shows all major milestones and deadlines linked with them. Then try to obtain approval for the schedule.
- B. Start the Quality assurance process by developing test procedures for the final deliverable and defining metrics against which the tests will be performed.
- C. Start developing a detailed Risk register which includes identified risks with their qualitative and quantitative assessments and a response plan.
- D. Obtain the documents which describe the project selection processes and make sure that they describe all decision processes and their outcomes.

**Answer: D (LEAVE A REPLY)**

#### **NEW QUESTION: 772**

You are trying to determine whether or not to conduct 100% final system tests of 500 ground-based radar units at the factory. The historical radar field failure rate is 4%; the cost to test each unit in the factory is \$10,000; the cost to reassemble each passed unit after the factory test is \$2,000; the cost to repair and reassemble each failed unit after factory test is \$23,000; and the cost to repair and reinstall each failed unit in the field is \$350,000. Using decision tree analysis, what is the expected value if you decide to conduct these tests?

- A. \$5.5 million
- B. \$5.96 million
- C. \$6.42 million
- D. \$7 million

**Answer: (SHOW ANSWER)**

Section: Mix Questions

Explanation:

Test: \$5M + \$960K + \$460K = \$6.42M; Don't Test: \$7M.

#### **NEW QUESTION: 773**

According to labor law, which of the following management actions are prohibited during a union organizing drive?

- A. Implementing previously scheduled pay raises
- B. Circulating anti-union petitions
- C. Forbidding unions from soliciting workers during working hours
- D. Forbidding employees from distributing union literature in working areas
- E. All of the other alternatives apply

**Answer: B (LEAVE A REPLY)**

#### **NEW QUESTION: 774**

Analogous Estimate Costs is \_\_\_\_\_.

- A. Generally Accurate
- B. Generally less accurate
- C. Bottom-up estimating
- D. None of the other alternatives apply

**Answer: B (LEAVE A REPLY)**

Analogous Estimate Costs is Generally less accurate. Analogous Estimate Costs Uses Expert Judgment. It is used when reference projects are similar. It is useful in early phases of the project.

#### **NEW QUESTION: 775**

You are planning to conduct the team-building portion of your new project management training curriculum out- of-doors in the local park. You are limited to scheduling the course at certain times of the year, and the best time for the course to begin is mid-July. One of the more common date constraints to use as you develop the project schedule is\_\_\_\_\_

- A. "Start no earlier than"
- B. "Finish no earlier than"
- C. "Fixed late start"
- D. "Fixed early finish"

**Answer: A (LEAVE A REPLY)**

Section: Mix Questions

Explanation:

Imposed dates on schedule activity starts or finishes can be used to restrict the start or finish to occur either no earlier than a specified date or no later than a specified date. Although all four date constraints typically are available in project management software, "start no earlier than" and "finish no later than" constraints are more commonly used.

#### **NEW QUESTION: 776**

You are managing a design project that would provide design drawings to your customer. The requirements of this project were not clearly defined in the beginning, and there would need to be many changes based on customer feedback as the project evolves. You elaborate the work of the

project to the level of detail you know at the time. Which of the following techniques would be the most helpful while defining activities for the project?

- A. Decomposition
- B. Rolling wave planning
- C. Just in time
- D. Extreme programming

**Answer: B ([LEAVE A REPLY](#))**

#### **NEW QUESTION: 777**

You are the project manager at a utility company. Due to the recent rise in the cost of petroleum, your organization is exploring cheaper, alternative forms of energy. You are in the process of developing the project charter. All of the following are tools/ techniques that you can use to develop the project charter EXCEPT:

- A. Project management methodologies
- B. PMIS
- C. Alternatives identification
- D. Expert judgment
- E. Project selection methods

**Answer: C ([LEAVE A REPLY](#))**

#### **NEW QUESTION: 778**

You are a project manager at a construction company, assigned to repaint the 30-story building. One of the initial tasks is to scrape the original paint off the building and then to prime the building. But before the building can be primed, the original paint must be scraped off the building. However, priming can begin while scraping is underway. The two tasks can progress in parallel. Which of the following relationship types best describes this dependency between scraping and priming?

- A. Start to start
- B. Finish to finish
- C. Finish to start
- D. Start to finish

**Answer: A ([LEAVE A REPLY](#))**

#### **NEW QUESTION: 779**

An agile team is geographically separated across multiple continents, and the project manager is identifying the tools to manage the communication among the virtual teams. Drag the appropriate tool on the left to each project task on the right.



Answer:

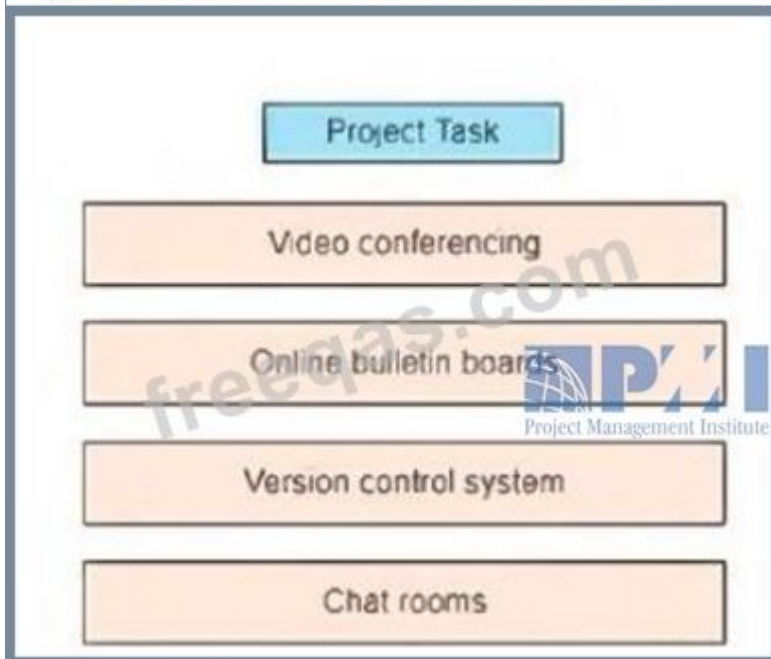
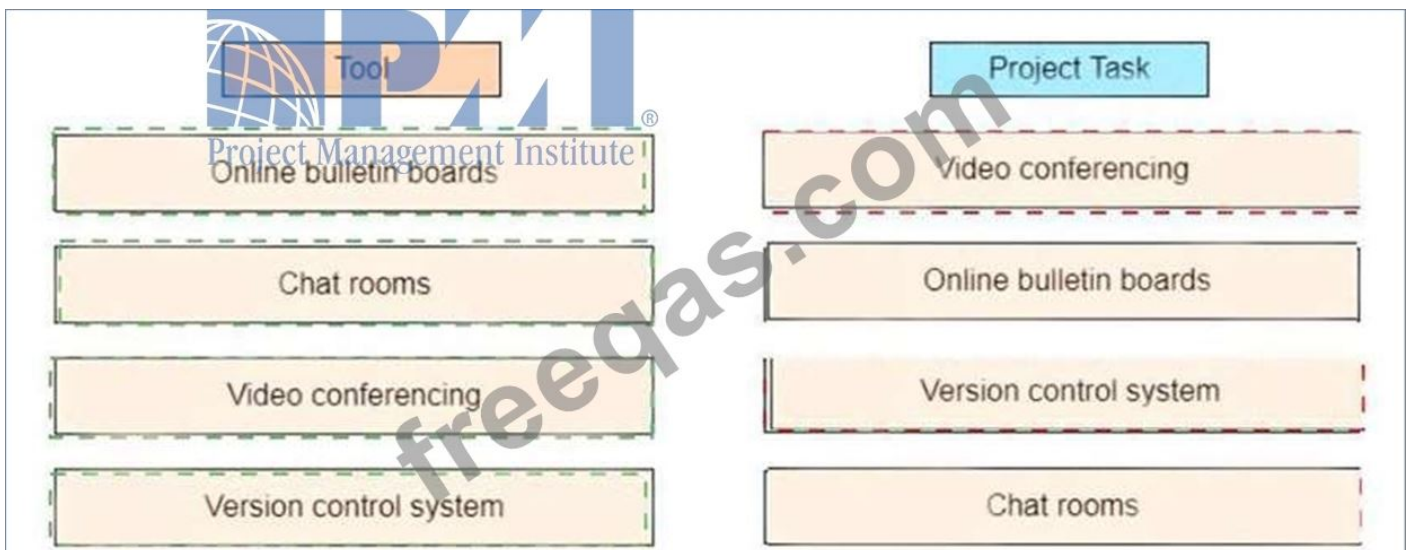

NEW QUESTION: 780

During a risk analysis of a new system's security features, it is discovered that some users may have access to noncritical customer data. Upon evaluation, the team agrees that the risk has a low probability of occurring. What should the project manager do with this information?

- A. Perform a qualitative analysis
- B. Perform an impact assessment
- C. Update the risk register
- D. Update the risk management plan.

**Answer: A ([LEAVE A REPLY](#))**

#### **NEW QUESTION: 781**

Which of the following Scope Management process involves breaking down a project into smaller manageable units?

- A. Scope Verification
- B. Initiation
- C. Scope Planning
- D. Scope Definition

**Answer: ([SHOW ANSWER](#))**

**Valid PMP Dumps** shared by PrepPdf.com for Helping Passing PMP Exam! PrepPdf.com now offer the **newest PMP exam dumps**, the PrepPdf.com PMP exam **questions have been updated** and **answers have been corrected** get the **newest** PrepPdf.com PMP dumps with Test Engine here: <https://www.preppdf.com/PMI/PMP-prepaway-exam-dumps.html> (2045 Q&As Dumps, **40%OFF Special Discount: Exam-Tests**)

#### **NEW QUESTION: 782**

Project management/project planning is most closely aligned with:

- A. Intermediate range planning (1 to 5 years) and Short range/tactical planning (1 year or less).
- B. Intermediate range planning (1 to 5 years)
- C. Short range/tactical planning (1 year or less).
- D. All of the other alternatives apply.
- E. Long range/strategic planning (5 years or more).

**Answer: ([SHOW ANSWER](#))**

#### **NEW QUESTION: 783**

A supporting input for controlling stakeholder engagement is \_\_\_\_\_

- A. Budget
- B. Project schedule
- C. Historical information
- D. Number of defects

**Answer: B ([LEAVE A REPLY](#))**

Explanation/Reference:

Explanation:

Project documents are an input to control stakeholder engagement. They originate from initiating, planning, executing, or controlling processes and include the project schedule, stakeholder register, issue log, change log, and project communications.

**NEW QUESTION: 784**

A quality management plan is created during which of the following?

- A. Perform Quality Assurance
- B. Project Executing
- C. Plan Quality
- D. Perform Quality Control

**Answer: ([SHOW ANSWER](#))**

**NEW QUESTION: 785**

Which of the following documents initiates a project and authorizes the project manager to assign organizational resources to the project?

- A. RFB document
- B. RFQ document
- C. Project charter
- D. Work breakdown structure
- E. Project plan

**Answer: C ([LEAVE A REPLY](#))**

**NEW QUESTION: 786**

The operations director complains to the CEO about the outcome of a project's first sprint. The operations department will not be able to support a new product due to poor performance indicators. The project team facilitator asks for feedback from the project team and is informed that performance information is available in the application server log. How should this complaint be addressed?

- A. Invite a member of the operations team to be part of the validation and sprint meetings
- B. Request that the issue be included in the next board of directors meeting to explain all of the needs
- C. Add the complaint to the product backlog to be addressed in the next sprint
- D. Ask the operations director to define the acceptance criteria to make clear the delivery is correct

**Answer: A ([LEAVE A REPLY](#))**

**NEW QUESTION: 787**

Rekha is a project manager on a large construction project. Late in the project, her client demands a big change. She assesses the impact of the change and tells the client how much time and money it will cost. But the client won't allow any change to the schedule and won't pay anything more for change. Rekha explains that the proposed change is well outside the documented scope of the original work. The client tells Rekha that he doesn't care what was in the original scope and that she needs to implement the change with no impact to schedule or budget. What conflict resolution technique is he the client using?

- A. Confronting
- B. Smoothing
- C. Withdrawal
- D. Forcing

**Answer: D (LEAVE A REPLY)**

The client is trying to command Rekha to do what he says even though she has good reasons for not doing it. He isn't working to solve the problem, he's just forcing the resolution to go his way.

#### **NEW QUESTION: 788**

Which input provides suppliers with a clear set of goals, requirements, and outcomes?

- A. Procurement statement of work
- B. Purchase order
- C. Source selection criteria
- D. Bidder conference

**Answer: A (LEAVE A REPLY)**

Section: Executing

#### **NEW QUESTION: 789**

The quality management plan describes all the following EXCEPT the\_\_\_\_\_

- A. Method for implementing the quality policy
- B. Methods the team will use to meet the project's quality requirements
- C. Efforts at the front end of a project to ensure that decisions are based on accurate information
- D. Procedures used to conduct trade-off analyses among cost, schedule, and quality

**Answer: D (LEAVE A REPLY)**

Section: Mix Questions

Explanation:

A part of the overall project management plan, the quality management plan should address all aspects of how quality management will be implemented on the project and how the project team will implement the quality policy. Trade-off analyses are business judgments and, as such, are not procedural steps to be included in the quality management plan.

#### **NEW QUESTION: 790**

Project schedule development is an iterative process. If the start and finish dates are not realistic, the project probably will not finish as planned. You are working with your team to define how to manage schedule changes. You documented your decisions in which of the following?

- A. Schedule change control procedures
- B. Schedule management plan
- C. Schedule risk plan
- D. Service-level agreement

**Answer: (SHOW ANSWER)**

Section: Mix Questions

Explanation:

The schedule management plan is part of the overall project management plan and defines, among other things, how schedule changes will be managed. Whether it is formal or informal, highly detailed or broadly framed, it generally is based on specific project needs.

#### **NEW QUESTION: 791**

A project has virtual teams in different geographic areas that are working on the same deliverables. Due to the project members' unavailability for conference calls, some milestones have been unmet.

What should the project manager do to resolve this matter and prevent future issues?

- A. Create and keep the resource calendar updated and shared with team members
- B. Ask the project teams to allocate more resources.
- C. Perform an analysis, and revise the action plan for resource allocation.
- D. Request that the functional team manager monitors team members' availability.

**Answer: A (LEAVE A REPLY)**

Section: Executing

#### **NEW QUESTION: 792**

Ranking risks is performed in which of the following?

- A. Expected monetary value (EMV).
- B. Risk triggers
- C. Qualitative Risk Analysis
- D. Workarounds

**Answer: C (LEAVE A REPLY)**

#### **NEW QUESTION: 793**

Thinking back to lessons that your company learned from experiences with its legacy information systems during the Y2K dilemma, you finally convinced management to consider systems maintenance from the beginning of the project. However, maintenance should\_\_\_\_\_

- A. Always be included as an activity to be performed during the closeout phase
- B. Have a separate phase in the life cycle for information systems project because 60% to 70% of computer systems' life-cycle costs generally are devoted to maintenance

- C. Not be viewed as part of the project life cycle
- D. Be viewed as a separate project

**Answer: (SHOW ANSWER)**

Explanation/Reference:

Explanation:

Projects are efforts that occur within a finite period of time with clearly defined beginnings and ends.

Maintenance is ongoing and of an indefinite duration. A maintenance activity, such as revision of an organization's purchasing guidelines, may be viewed as a project but is a separate and distinct undertaking from the initial project that generated it. At this point, the project has been completed, and its deliverables are transferred to operations for implementation.

#### **NEW QUESTION: 794**

Typically, the statement "no one likes to estimate, because they know their estimate will be proven incorrect" is true. However, you have been given the challenge of estimating the costs for your nuclear reactor project. A basic assumption that you need to make early in this is \_\_\_\_\_

- A. How direct and indirect costs will be handled
- B. Whether or not experts will be available to assist you in this process
- C. If there will be a multiyear project budget
- D. Whether the project has required delivery dates

**Answer: A (LEAVE A REPLY)**

Explanation/Reference:

Explanation:

The scope statement, as part of the scope baseline, is a key input in the estimate costs process and should be reviewed. It provides the project description, acceptance criteria, key deliverables, boundaries, assumptions, and constraints about the project. It also notes one basic assumption that must be made as costs are estimated is whether the estimates will be limited only to direct project costs or whether they also will include indirect project costs.

#### **NEW QUESTION: 795**

A company has always acquired very specialized services from local companies for its projects. During the planning stage for a regulatory project, the project manager is informed that local vendors would not be able to operate due to an unexpected major event. There is an option to hire the same services from companies in other countries.

What should the project manager do in this situation?

- A. Create a change request to extend the duration of the project.
- B. Plan to execute the procurement tasks in a virtual environment.
- C. Review organizational process assets (OPAs) for similar projects.
- D. Ask the project sponsor to put the project on hold.

**Answer: (SHOW ANSWER)**

**NEW QUESTION: 796**

You are the finance controller with your company. Your job is to analyze projects when they close. This could be the result of when a project is complete or by any other means. When would you expect to close a project?

- A. When a project is canceled
- B. When a project runs out of money
- C. When a project completes Scope Verification
- D. All of the answers

**Answer: (SHOW ANSWER)**

Section: Mix Questions

Explanation/Reference:

**Valid PMP Dumps** shared by PrepPdf.com for Helping Passing PMP Exam! PrepPdf.com now offer the **newest PMP exam dumps**, the PrepPdf.com PMP exam **questions have been updated** and **answers have been corrected** get the **newest** PrepPdf.com PMP dumps with Test Engine here: <https://www.preppdf.com/PMI/PMP-prepaway-exam-dumps.html> (2045 Q&As Dumps, **40%OFF Special Discount: Exam-Tests**)

**NEW QUESTION: 797**

Which of the following project would be BEST project to select?

- A. Project C will take 8 years to complete and has NPV value \$50,000
- B. Project D will take 10 years to complete and has NPV value \$55,000
- C. Project A will take 3 years to complete and has NPV value \$70,000
- D. Project B will take 4 years to complete and has NPV value \$60,000

**Answer: C (LEAVE A REPLY)**

NPV (Net present value):The present value of cash inflow less the present value of cash outflow.

< li >A negative NPV is unfavorable;

< li >the higher the NPV, the better.

< li >Project year is already included therefore choose best NPV value always.

**NEW QUESTION: 798**

A purchase order is a good example of which form of contracting?

- A. Unilateral
- B. Bilateral
- C. Trilateral
- D. Severable

**Answer: (SHOW ANSWER)**

Section: Mix Questions

Explanation:

The purchase order is a unilateral (one signature) offer that includes a promise to pay upon delivery.

**NEW QUESTION: 799**

Which tool or technique is used to manage change requests and the resulting decisions?

- A. Change log
- B. Expert judgment
- C. Change control tools
- D. Delphi technique

**Answer: C ([LEAVE A REPLY](#))**

**NEW QUESTION: 800**

A project manager is working on a product-line project with a specific deadline. During execution the customer realizes that some extra requirements need to be added and informs the project manager.

What should the project manager do next after receiving the customer's request?

- A. The project manager should record the request in writing and then verify the cost and schedule impacts prior to approval.
- B. The project manager should record this request in the risk management plan and inform stakeholders through the approved communication channels.
- C. The project manager should perform a root cause analysis of the change and record the findings in the lessons learned register.
- D. The project manager should inform the project team about the new scope of work so they can propose strategies for completing the project on time.

**Answer: A ([LEAVE A REPLY](#))**

**NEW QUESTION: 801**

Risk categorization is a tool or technique used in which process?

- A. Plan Risk Responses
- B. Plan Risk Management
- C. Perform Qualitative Risk Analysis
- D. Perform Quantitative Risk Analysis

**Answer: C ([LEAVE A REPLY](#))**

Section: Planning

Explanation/Reference:

**NEW QUESTION: 802**

A proved manager joins a protect with cross-functional stakeholders and a fixed go-live date. The project manager wants to quickly gather requirements and ensure all stakeholders are aligned so that any conflicts are flagged as easily as possible.

What should the project manager do?

- A. Use facilitation techniques with all stakeholders
- B. Send a questionnaire to all stakeholders.
- C. Set up job-shadowing sessions for all stakeholders
- D. Conduct individual interviews with each stakeholder

**Answer: A ([LEAVE A REPLY](#))**

#### **NEW QUESTION: 803**

The integrative nature of project management requires which Process Group to interact with the other Process Groups?

- A. Planning
- B. Executing
- C. Monitoring and Controlling
- D. Project Management

**Answer: C ([LEAVE A REPLY](#))**

Section: Executing

#### **NEW QUESTION: 804**

Stakeholders can be identified in later stages of the project because the Identify Stakeholders process should be:

- A. Continuous
- B. Discrete
- C. Regulated
- D. Arbitrary

**Answer: A ([LEAVE A REPLY](#))**

Section: Initiation

#### **NEW QUESTION: 805**

Organizational downsizing has resulted in the key subject matter expert (SME) resource leaving a multiyear project. What should the project manager do?

- A. Modify the statement of work (SOV).
- B. Refer to the resource management plan.
- C. Consult the project sponsor.
- D. Update the stakeholder register.

**Answer: B ([LEAVE A REPLY](#))**

#### **NEW QUESTION: 806**

Configuration identification, configuration status accounting, and configuration verification and audit are all activities in which process?

- A. Perform Quality Assurance
- B. Direct and Manage Project Work
- C. Monitor and Control Project Work
- D. Perform Integrated Change Control

**Answer:** ([SHOW ANSWER](#))

Section: Monitoring and Controlling

#### **NEW QUESTION: 807**

During a project's execution, the project manager discovers a risk with an unknown impact. How should the project manager manage this?

- A. Assume the impact of the risk to be low, log it accordingly in the risk register, and continuously monitor it
- B. Communicate the risk to the project team, ask them to monitor the risk, and implement a mitigation strategy
- C. Discuss the risk with the team, log it in the risk register, and update its status throughout the project
- D. Assume a worst-case scenario for the risk, and establish a contingency reserve to address its impact

**Answer:** B ([LEAVE A REPLY](#))

Section: Monitoring and Controlling

#### **NEW QUESTION: 808**

One of the most common pitfalls in effective communication is:

- A. not selecting the correct medium
- B. not selecting the correct medium and not considering the position of the receiver
- C. assuming that because a message is sent, it has been received
- D. All of the other alternatives apply.
- E. not considering the position of the receiver

**Answer:** ([SHOW ANSWER](#))

#### **NEW QUESTION: 809**

A project manager is assigned to an automotive product development project in the middle of the pilot phase.

According to the test lab, a durability test was completed with good results 6 weeks ago but there were no reports left behind by the test engineer who left the organization the previous month.

What should the previous project manager have done to prevent this issue?

- A. Contracted with a third-party test lab to outsource all testing processes and required that they produce all test reports

- B. Built a pair-engineering environment so that experienced engineers always work with junior engineers to assist in knowledge transfer
- C. Led a technical benchmark workshop every month to share state-of-the-art technology trends and ask all team members to attend the workshop
- D. Built a shared repository for the project in the internal server and asked the team to create record and save all project deliverables to the server

Answer: ([SHOW ANSWER](#))

#### NEW QUESTION: 810

You receive 25 new computers from the seller, but were expecting only 20. In looking at the contract, you see that it says "seller to provide twenty (25) computers." What should you do FIRST?

- A. Make payment for the 25 computers.
- B. Issue a change order through the contract manager.
- C. Return the five extra computers.
- D. Call the seller and ask for clarification.

Answer: ([SHOW ANSWER](#))

#### NEW QUESTION: 811

Which of the following techniques is used during Control Scope?

- A. Cost-benefit analysis
- B. Variance analysis
- C. Reserve analysis
- D. Stakeholder analysis

Answer: ([SHOW ANSWER](#))

Section: Executing

**Valid PMP Dumps** shared by PrepPdf.com for Helping Passing PMP Exam! PrepPdf.com now offer the **newest PMP exam dumps**, the PrepPdf.com PMP exam **questions have been updated** and **answers have been corrected** get the **newest** PrepPdf.com PMP dumps with Test Engine here: <https://www.preppdf.com/PMI/PMP-prepaway-exam-dumps.html> (2045 Q&As Dumps, **40%OFF Special Discount: Exam-Tests**)

#### NEW QUESTION: 812

A project manager works for a large software development company that has multiple strategic business groups. The project manager has been assigned to develop maintenance planning software for a power plant. The project manager heard that a similar project that was executed by another business group in the company recently failed. The project manager is concerned about

the project's performance and wants to take steps to help the project succeed. What should the project manager do?

- A. Evaluate the project risk and try to replace the project with another one within the organization.
- B. Continue executing the project using the project manager's usual methods as all projects are unique.
- C. Study and apply the lessons learned from the failed project so that this project does not follow the same pattern.
- D. Inform the project sponsor about the risk and try to convince them to withdraw the project.

**Answer:** ([SHOW ANSWER](#))

### **NEW QUESTION: 813**

As project manager, you identified a number of acceptable tolerances as part of your earned value management system. During execution, some "unacceptable" variances occurred. After each

"unacceptable" variance occurred, you did which one of the following first?

- A. Updated the budget
- B. Prepared a revised cost estimate
- C. Adjusted the project plan
- D. Documented lessons learned

**Answer:** D ([LEAVE A REPLY](#))

Explanation/Reference:

Explanation:

Lessons learned but not documented are "lessons lost." The lessons learned knowledge database will help current project members, as well as people on future projects, make better decisions. Accordingly, the reasons for the variance, the rationale supporting the corrective action, and other related information must be documented. They require updates as part of updates to organizational process assets as an output of control costs in terms of corrective actions taken and why they were selected.

### **NEW QUESTION: 814**

As a good project approaches its final phase. the project manager sends a follow-up report to the stakeholders Some stakeholders comment that some unresolved issues have been excluded from the report.

What should the project manager have done to prevent this?

- A. Implemented the Monitor Risks process
- B. Followed the Perform Integrated Change Control process
- C. Better controlled project documents
- D. Conducted the Monitor Communications process

**Answer:** A ([LEAVE A REPLY](#))

### **NEW QUESTION: 815**

Outputs from Organizational Planning include all of the following except:

- A. Role and Responsibility Matrix
- B. Staffing Management Plan
- C. Project Team Directory
- D. Organization Chart

**Answer: C ([LEAVE A REPLY](#))**

**NEW QUESTION: 816**

A project manager is leading an electrical project that spans five towns. The project manager is informed by the team that one of the towns is not allowing the team to work there even though the town was included in stakeholder engagements before the start of the project.

What should the project manager do?

- A. Engage with the town's authorities to discuss the reason for the change in commitment and agree on a solution.
- B. Instruct the team to move to the next town and continue the project to avoid further delays.
- C. Change the project scope and seek approval to exclude this town from the overall project.
- D. Retrieve all minutes of stakeholder engagements and send to the town as a reminder of their commitment to the project.

**Answer: C ([LEAVE A REPLY](#))**

**NEW QUESTION: 817**

A project manager expected a vendor to complete testing of each component they produced and was surprised to discover that no testing was done. To recover, the project team performs a statistical sampling of the components. Where should the testing requirements have been recorded?

- A. Contract change documentation
- B. Procurement management plan
- C. Requirements management plan
- D. Quality management plan

**Answer: ([SHOW ANSWER](#))**

**NEW QUESTION: 818**

You are a project manager working on a large construction project. During the implementation phase of the project, a new sponsor is assigned to the project. If the sponsor wants to understand which tasks each member of your team is responsible for completing, what tool would you use to help clarify this for your project sponsor?

- A. Flowchart
- B. Hierarchical-type organization chart
- C. RACI chart
- D. Network

**Answer: C ([LEAVE A REPLY](#))**

**NEW QUESTION: 819**

A project manager is working in a hybrid environment using both waterfall and agile frameworks. This causes some confusion about who does what throughout the project. What can the project manager do to help clear the confusion?

- A. Detail the roles and responsibilities in the project charter.
- B. Invite the project sponsor to the project kick-off meeting.
- C. Send out an email to the project team to clarify who is responsible for what as it arises.
- D. Develop the resource management plan by defining the roles and responsibilities.

**Answer:** ([SHOW ANSWER](#))

**NEW QUESTION: 820**

A project team member informs the project manager that a stakeholder is contacting the team member to request status updates. The team member is being distracted by these repeated requests, which are interfering with the completion of assigned tasks.

What should the project manager do?

- A. Raise this issue to the project sponsor in the next project status review meeting.
- B. Review this stakeholder's communication requirements.
- C. Increase the frequency of updates given to this stakeholder.
- D. Inform the team member to stop sending any further updates to the stakeholder.

**Answer:** ([SHOW ANSWER](#))

**NEW QUESTION: 821**

Which project management process group takes maximum time and resource in a project?

- A. planning
- B. initiation
- C. execution
- D. closing

**Answer:** C ([LEAVE A REPLY](#))

Execution project management process group takes maximum time and resource in a project. For project execution you need most of the resources and time.

**NEW QUESTION: 822**

One of the team members has been reporting their activities exclusively to their functional manager, instead of following the established procedure of activity reporting within the project management information system (PMIS). What should the project manager do?

- A. Update the communications management plan to eliminate activity reporting in this particular case.
- B. Escalate the issue to the project sponsor, indicating a breach of the communications management plan.

C. Review the communications management plan with the functional manager and the team member.

D. Send the communications management plan to the functional manager and all team members.

**Answer: C ([LEAVE A REPLY](#))**

Section: Monitoring and Controlling

### **NEW QUESTION: 823**

An impact assessment reveals that a deliverable could be delayed by two weeks. A key resource has not been available to work on a non-critical activity due to other priorities. This could cause work overload on the other remaining resources.

Since cost is a major constraint for this project, what should the project manager do immediately?

A. Determine if the task has available float to meet the project end date.

B. Hire a temporary resource to do the job.

C. Consult the team and reduce the scope.

D. Change the resource calendar to avoid major delays.

**Answer: A ([LEAVE A REPLY](#))**

Section: Executing

Explanation/Reference:

### **NEW QUESTION: 824**

When items to be purchased for a project are specified by performance characteristics:

A. Both 1) the supplier is held liable for the operation of the item, and 2) the supplier is held liable for that the item meets the design, dimensions, and tolerance specifications.

B. paperwork is greatly reduced

C. the supplier is held liable for the maintenance of the item

D. the supplier is held liable for the operation of the item

E. the supplier is held liable for that the item meets the design, dimensions, and tolerance specifications.

**Answer: ([SHOW ANSWER](#))**

### **NEW QUESTION: 825**

Which of the following networking methods allows us to show that the last 10% of one element cannot be completed until 62% of a previous element has been completed?

A. ADM

B. PERT

C. All of the other alternatives apply.

D. PDM

E. PERT and PDM.

**Answer: ([SHOW ANSWER](#))**

### **NEW QUESTION: 826**

An output of the Create WBS process is:

- A. Scope baseline.
- B. Project scope statement.
- C. Organizational process assets.
- D. Requirements traceability matrix.

**Answer: ([SHOW ANSWER](#))**

Section: Planning

**Valid PMP Dumps** shared by PrepPdf.com for Helping Passing PMP Exam! PrepPdf.com now offer the **newest PMP exam dumps**, the PrepPdf.com PMP exam **questions have been updated** and **answers have been corrected** get the **newest** PrepPdf.com PMP dumps with Test Engine here: <https://www.preppdf.com/PMI/PMP-prepaway-exam-dumps.html> (2045 Q&As Dumps, **40%OFF Special Discount: Exam-Tests**)

**NEW QUESTION: 827**

During a project review, the construction manager reports that the concrete production rate has changed over the last three months. What analysis should be conducted?

- A. Earned value (EV)
- B. Critical path
- C. Trend
- D. Cost

**Answer: ([SHOW ANSWER](#))**

Section: Monitoring and Controlling

**NEW QUESTION: 828**

Drag the items on left side to the matching term within the correct project.

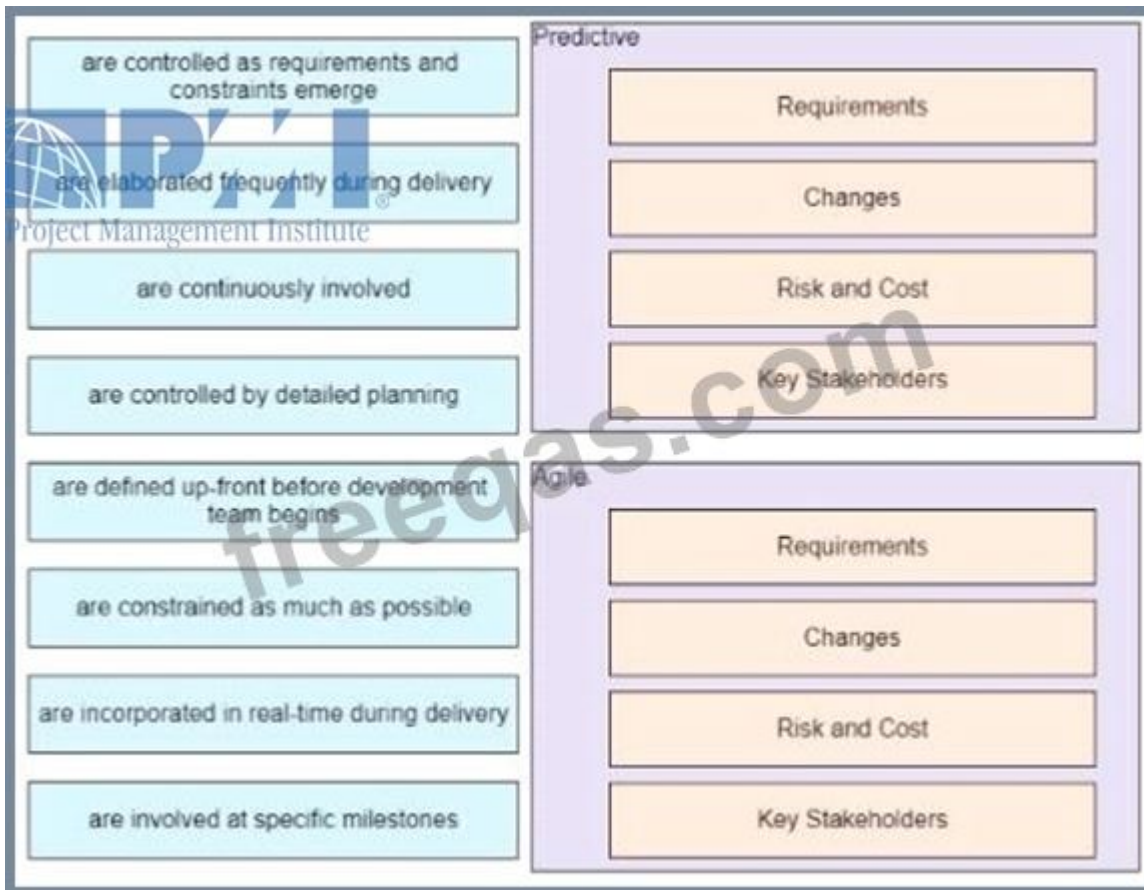

**Answer:**



**NEW QUESTION: 829**

After performing a risk analysis, the project manager realizes that the project team may be unable to develop a final project module on time and within quality standards. This could cause a financial loss to the company. The project manager decides to engage vendor to deliver that module using a firm fixed price (FFP) contract.

What risk response strategy did the project manager use?

- A. Transfer
- B. Mitigate
- C. Avoid
- D. Share

**Answer:** ([SHOW ANSWER](#))

**NEW QUESTION: 830**

A project manager is working on a large project with a very difficult client. During the course of the project, the project manager realizes that if the project team had a little more time and funding to make some minor changes, the client could realize the benefits of 25% of the project outcomes early.

How should the project manager approach this?

- A. Concentrate on the current project milestones.
- B. Develop a business case and submit it to the client.
- C. Update the project management plan for this new work.
- D. Make all the changes and then show the client the results.

**Answer:** B ([LEAVE A REPLY](#))

**NEW QUESTION: 831**

Which of the following statements regarding WBS is false?

- A. The work package is the lowest level in the WBS
- B. The WBS is an outcome of the Create WBS process
- C. To identify the major deliverables of the project requires analyzing the preliminary project scope statement
- D. Different deliverables in the WBS can have different levels of decomposition
- E. A WBS from a previous project can often be used as a template for a new project

**Answer:** C ([LEAVE A REPLY](#))

**NEW QUESTION: 832**

Which type of project management office (PMO) supplies templates, best practices, and training to project teams?

- A. Instructive
- B. Supportive
- C. Controlling
- D. Directive

**Answer:** ([SHOW ANSWER](#))

**NEW QUESTION: 833**

A project manager has received an updated earned value analysis report. The following are the key findings from the report:

- \* Budget at completion = US\$1 million
- \* Earned value = US\$0.7 million
- \* Actual cost = US\$0.75 million
- \* Cost performance index = 0.933

Based on this information, what should the project manager conclude about project performance?

- A. The project will be difficult to complete as planned.
- B. The project will not be completed as planned.
- C. The project will be completed exactly as planned.
- D. The project will be easier to complete than planned.

**Answer: B (LEAVE A REPLY)**

**NEW QUESTION: 834**

The cost of nonconformance in a project includes:

- A. training
- B. inspections
- C. rework
- D. testing

**Answer: C (LEAVE A REPLY)**

**NEW QUESTION: 835**

A mobile application is being developed in more than 10 languages for a large and varied group of business users. The project manager must determine whether or not to perform a full inspection of the application in all languages, or to use sampling techniques.

What additional information should the project manager gather before proposing an inspection strategy?

- A. Results of a cost-benefit analysis
- B. Analysis of a probability and impact matrix
- C. Number of users for each language
- D. Quality metrics for the project

**Answer: A (LEAVE A REPLY)**

Section: Planning

Explanation

**NEW QUESTION: 836**

The communication technology being applied in a project was tested in simulated environments but never in actual projects. This lack of experience with the technology must be addressed in detail.

Which of the following strategies should be used in the project's planning process?

- A. Update the project scope if the project grows more complex
- B. Provide a status update to senior management
- C. Exploit the threat by using an alternative technology.
- D. Mitigate the risk by conducting a pilot

Answer: ([SHOW ANSWER](#))

**NEW QUESTION: 837**

3 major processes in Project HRM

- A. Staff acquisition, staff training, and staff deployment
- B. Rewarding, salary reviews and penalties
- C. Staff recruitment, project staff planning and team building
- D. Organizational planning, staff acquisition and team development

Answer: ([SHOW ANSWER](#))

**NEW QUESTION: 838**

Which of the following statements are FALSE regarding project scope management plan?

- A. The project scope management plan is an output of the Scope Definition process
- B. The project scope management plan describes how the project scope will be defined and managed by the project scope management team
- C. Project scope management plan specifies how WBS will be created, maintained and approved
- D. Project scope management plan specifies how changes to the project scope statement will be managed.
- E. The project scope management plan is contained within the project management plan

Answer: A ([LEAVE A REPLY](#))

**NEW QUESTION: 839**

What risk response strategy should the project manager use?

- A. Mitigate
- B. Exploit
- C. Transfer
- D. Accept

Answer: A ([LEAVE A REPLY](#))

**NEW QUESTION: 840**

You are project manager for a project with a multi-million value assigned by a company that is listed at a US stock exchange.

Recent Earned value analysis after app. 25% completion told you that your project has a CPI of 0.76. What should you do right now?

- A. You should immediately inform your management, which should then assess whether this CPI constitutes a material financial issue.
- B. The variance is a signal of a sound project which is well under budget. There is no need for action.
- C. It is still early in the project and data are yet inaccurate. Wait a while and allow numbers from the project to stabilize.
- D. A project that much under budget may be a problem for negotiating future budgets. Try to spend money somewhere else.

**Answer:** ([SHOW ANSWER](#))

**NEW QUESTION: 841**

A company is implementing a new IT tool but the project is behind and the functionality does not adhere to the expected scope indicated in the contract During a steering committee meeting, it is decided that the project should be terminated immediately due to poor vendor performance.

What should the project manager do next?

- A. Assemble lessons learned.
- B. Archive project documents and materials
- C. Obtain final acceptance of the project deliverables
- D. Transfer ownership of the deliverables to assigned stakeholders

**Answer: A** ([LEAVE A REPLY](#))

**Valid PMP Dumps** shared by PrepPdf.com for Helping Passing PMP Exam! PrepPdf.com now offer the **newest PMP exam dumps**, the PrepPdf.com PMP exam **questions have been updated** and **answers have been corrected** get the **newest** PrepPdf.com PMP dumps with Test Engine here: <https://www.preppdf.com/PMI/PMP-prepaway-exam-dumps.html> (2045 Q&As Dumps, **40%OFF Special Discount: Exam-Tests**)

**NEW QUESTION: 842**

The basic approach to quality management in projects is to be compatible with which of the following:

- A. Six-Sigma, failure mode and effect analysis, and total quality management
- B. The International Organization for Standardization (ISO)
- C. Methods, such as those recommended by Deming, Juran, and Crosby
- D. Inspection over prevention

**Answer: B** ([LEAVE A REPLY](#))

Section: Mix Questions

Explanation:

Project quality management is intended to be compatible with International Organization for Standardization quality standards.

**NEW QUESTION: 843**

The only Process Group that comprises processes that typically occur from the beginning to the end of the project life cycle is:

- A. Planning.
- B. Executing,
- C. Monitoring and Controlling.
- D. Closing.

**Answer:** ([SHOW ANSWER](#))

Section: Planning

**NEW QUESTION: 844**

You have outsourced programming to a company in another country and structural engineering to a company in a different country. The project does not have the budget to bring all the teams together, so you must rely on email, fax, videoconference, and chat to work together. This is an example of:

- A. Virtual Team
- B. Global Team
- C. Cross Functional Global Team
- D. Diverse Team

**Answer:** ([SHOW ANSWER](#))

**NEW QUESTION: 845**

Which of the following is not a measure of the profitability of a project or program?

- A. None of the other alternatives apply
- B. Return on original investment.
- C. Net present value.
- D. Depreciation.
- E. Discounted cash flow.

**Answer:** ([SHOW ANSWER](#))

**NEW QUESTION: 846**

Which item is an example of personnel assessment?

- A. Team-building activity
- B. Focus group
- C. Tight matrix
- D. Resource calendar

**Answer:** B ([LEAVE A REPLY](#))

**NEW QUESTION: 847**

Which group creativity technique asks a selected group of experts to answer questionnaires and provide feedback regarding the responses from each round of requirements gathering?

- A. The Delphi technique
- B. Nominal group technique
- C. Affinity diagram
- D. Brainstorming

**Answer: A ([LEAVE A REPLY](#))**

Section: Initiation

#### **NEW QUESTION: 848**

During a project's execution phase the customer insists on additions to product requirements. What should the project manager do first?

- A. Analyze the impact and submit a change request to the change control board (CCB)
- B. Communicate the impact of the new additions to the customer
- C. Determine if the additions can be accommodated within the current cost and schedule baseline
- D. Incorporate the additions into the schedule and submit a revised baseline to the customer

**Answer: A ([LEAVE A REPLY](#))**

#### **NEW QUESTION: 849**

Earned value analysis is a performance reporting tool/ technique. Which of the following best describes earned value (EV)?

- A. Value of the work completed
- B. Total of costs incurred in performing work activity
- C. Portion of approved cost estimate planned to be spent
- D. Efficiency indicator to reflect schedule performance of project
- E. Efficiency indicator to reflect cost performance of project

**Answer: ([SHOW ANSWER](#))**

#### **NEW QUESTION: 850**

The Project Manager has scheduled weekly status meetings with the team. The meetings have been unorganized with multiple people addressing their own needs and taking longer than planned with no discipline. Which of the following would improve the meetings?

- A. Create and publish an agenda, and establish the leader of the meeting
- B. Determine who is in charge of the meeting
- C. Send the team to communication training
- D. Create and publish an agenda

**Answer: A ([LEAVE A REPLY](#))**

#### **NEW QUESTION: 851**

A company has an existing contract to maintain and enhance a client's customer database. The company's legal department informs the project manager that a new piece of legislature requiring

stricter protection of customer information might soon be signed into law. The law will require additional security features to be implemented into the database the project manager is maintaining. These features are not included in the scope of the current contract. What should the project manager do?

- A. Update the risk register to include this issue and discuss the appropriate risk response plans with the project sponsor and client
- B. Ask the legal department to raise the issue in the next contract negotiation with the customer
- C. Seek the project sponsor's support to influence the client to amend the contract immediately
- D. Wait until the legal requirements are finalized so the change in scope can be concretely defined

**Answer: A ([LEAVE A REPLY](#))**

### **NEW QUESTION: 852**

There is high variability of scope in a project due to several key stakeholders across various departments.

What should the project manager do to check the costs against the delivered scope?

- A. Use the scope change request forms and estimate the costs against the scope changes.
- B. Find opportunities to eliminate any changes to scope and use a speed-to-delivery strategy.
- C. Facilitate frequent, incremental deliveries to customer value and verify that the team is working at the planned rate.
- D. Continue tracking costs in the performance reporting, and report the status to management for resolution.

**Answer: D ([LEAVE A REPLY](#))**

Section: Executing

### **NEW QUESTION: 853**

Verification of project deliverables occurs during which process?

- A. Create WBS
- B. Develop project charter
- C. Close Project or Phase
- D. Develop preliminary project scope statement

**Answer: C ([LEAVE A REPLY](#))**

### **NEW QUESTION: 854**

The nature of project work is such that it inevitably causes stress. Project managers thus need to learn how to cope with and manage stress and understand what stress is and why it is created. Project managers need to note that it can be a positive experience depending on how people perceive stress and should work to mentor team members accordingly. As you strive to become more aware of stress, which one of the following is NOT considered a stress-creating factor that is related to the project environment?

- A. Role ambiguity

- B. Corporate politics
- C. Career development
- D. Selection of team members

**Answer: A ([LEAVE A REPLY](#))**

Explanation/Reference:

Explanation:

The main sources of stress are grouped into four categories of stress-creating factors: those related to roles and relationships, those related to the job environment, personal factors, and factors related to the project environment or climate. Role ambiguity is an example of factors related to roles and responsibilities. It occurs when an individual is not clear about his or her job responsibilities.

### **NEW QUESTION: 855**

The purpose of work performance data in control communications is to present results of comparative analysis to the\_\_\_\_\_

- A. Performance measurement baseline
- B. Communications management plan
- C. Stakeholder management plan
- D. Deliverable status

**Answer: ([SHOW ANSWER](#))**

Explanation/Reference:

Explanation:

Work performance data are an input in control communications. These data organize and summarize information gathered and present the results of comparative analysis to the performance measurement baseline.

### **NEW QUESTION: 856**

The purpose of using what-if analysis in schedule control is to\_\_\_\_\_

- A. Review scenarios to bring the schedule in line with the plan
- B. Document requested changes
- C. Provide additional details as to when the schedule baseline should be updated
- D. Update the activity attributes

**Answer: A ([LEAVE A REPLY](#))**

Section: Mix Questions

Explanation:

A corrective action is anything that is done to bring expected future schedule performance in line with the schedule baseline. Regarding the project schedule, it usually means taking action to speed up the project. One way to determine why the schedule performance is not in line with the plan is what-if analysis, which may address schedule activities and other scenarios other than the activity that is actually causing the variance. It evaluates scenarios in order to predict their effect on the project's outcomes, either positive or negative.

**Valid PMP Dumps** shared by PrepPdf.com for Helping Passing PMP Exam! PrepPdf.com now offer the **newest PMP exam dumps**, the PrepPdf.com PMP exam **questions have been updated** and **answers have been corrected** get the **newest** PrepPdf.com PMP dumps with Test Engine here: <https://www.preppdf.com/PMI/PMP-prepaway-exam-dumps.html> (2045 Q&As Dumps, **40%OFF Special Discount: Exam-Tests**)

**NEW QUESTION: 857**

A project manager arranged a team-building activity to build and maintain teamwork, trust, and commitment due to internal team conflicts. Two months after completing the training, another situation is causing new delays in the project.

What should the project manager do to address this concern?

- A. Ask human resources (HR) to coordinate another activity.
- B. Meet with the team to explain that conflicts must be addressed and solved.
- C. Inform HR about the situation and ask for support.
- D. Reassess the team situation and provide a proper solution.

**Answer: D** ([LEAVE A REPLY](#))

**NEW QUESTION: 858**

At the time the risk register is first prepared, it should contain all the following entries EXCEPT \_\_\_\_\_

- A. Root causes of risk
- B. Structure for describing risks
- C. List of risks requiring near-term responses
- D. List of potential responses

**Answer: (**[SHOW ANSWER](#)**)**

Section: Mix Questions

Explanation:

The primary outputs from identify risks are initial entries into the risk register. It ultimately contains outcomes of other risk management processes as they are conducted. As an output of identify risks, the risk register should contain a list of identified risks, a list of potential responses, root causes that gave rise to the identified risks, and a structure for describing risks.

**NEW QUESTION: 859**

Your project management office implemented a project management methodology that emphasizes the importance of integrated change control. It states that change requests can occur in all the following forms EXCEPT \_\_\_\_\_

- A. Indirect
- B. Legally mandated

- C. Informal
- D. Internally initiated

**Answer: C ([LEAVE A REPLY](#))**

Section: Mix Questions

Explanation:

Change requests are an input to the perform integrated change control process. Although occurring in many forms, they must be formal requests developed within the context of a change control system consisting of documented procedures.

**NEW QUESTION: 860**

A project manager must track schedule variances over time. What tool or technique should be used to determine whether or not the variances are within acceptable limits?

- A. Cause-and-effect diagram
- B. Control chart
- C. Scatter diagram
- D. Control panel diagram

**Answer: ([SHOW ANSWER](#))**

Section: Monitoring and Controlling

**NEW QUESTION: 861**

Which of the following s most likely to require a rebaselining in order to provide a realistic measure of performance?

- A. Budget updates
- B. Corrective actions
- C. Revised cost estimates
- D. Change requests

**Answer: ([SHOW ANSWER](#))**

**NEW QUESTION: 862**

You are responsible for preparing a cost estimate for a large World Bank project. You decide to prepare a bottom-up estimate because your estimate needs to be as accurate as possible. Your first step is to\_\_\_\_\_

- A. Locate a computerized tool to assist in the process
- B. Use the cost estimate from a previous project to help you prepare this estimate
- C. Identify and estimate the cost for each work package or activity
- D. Consult with subject matter experts and use their suggestions as the basis for your estimate

**Answer: ([SHOW ANSWER](#))**

Section: Mix Questions

Explanation:

Bottom-up estimating is derived by first estimating the cost of the project's elemental tasks at the lower levels of the WBS or for an activity and then aggregating those estimates at successively higher levels of the WBS for subsequent reporting and tracking purposes.

**NEW QUESTION: 863**

You are the project manager responsible for constructing new 100-unit apartment in downtown Manhattan. As part of construction project, you are planning to outsource the electrical wiring of the building to an outside contracting firm. The contracting firm has requested a statement of work from you. Which of the following statements are FALSE regarding the contract SOW?

- A. The SOW is an output of the and acquisitions process and an input to the plan contracting process
- B. The SOW contains the objectives of the project
- C. As a buyer, you re required to write SOW
- D. The outside contracting firm requires a SOW to determine they have the capabilities to meet the detailed specifications of the project

**Answer: C ([LEAVE A REPLY](#))**

**NEW QUESTION: 864**

A team member is hosting an event and invites several colleagues through their work calendars Another team member, who was not invited to the event, is noticeably distracted during several standup meetings What should the project manager do?

- A. Ask the individual who is hosting the event to use private communication methods.
- B. Set up a meeting with the distracted team member to discuss any issues
- C. Add a social events section to the charter to handle these situations
- D. Ask the individual who is hosting the event to mark it as private

**Answer: B ([LEAVE A REPLY](#))**

**NEW QUESTION: 865**

Which Define Activities output extends the description of the activity by identifying the multiple components associated with each activity?

- A. Activity attributes
- B. Project document updates
- C. Activity list
- D. Project calendars

**Answer: ([SHOW ANSWER](#))**

**NEW QUESTION: 866**

Complete the following sentence: "The later a defect is found, \_\_\_\_\_."

- A. the more expensive it is to repair
- B. the easier it is to find
- C. the less important it is to the product

D. the faster it is to repair

**Answer:** ([SHOW ANSWER](#))

The reason we work to do quality planning up front is that it is most expensive to deal with problems if you find them late in the project. The best case is when you never inject the defects in the first place, then it doesn't cost anything to deal with them. Prevention is always better than inspection.

**NEW QUESTION: 867**

A team that is just forming needs:

- A. Opportunities for dialogue and conflict resolution
- B. Structure and specificity
- C. An organization chart
- D. Orientation and organization
- E. Alternatives and choices

**Answer:** ([SHOW ANSWER](#))

**NEW QUESTION: 868**

The Japanese Quality Control (QC) Circle movement motivated its participants in many ways. Which of the following represents the most important motivation for the QC circle participants?

- A. strengthening of relationships between co-workers
- B. self-improvement
- C. financial incentives
- D. recognition among co-workers
- E. improving the performance of the company

**Answer:** ([SHOW ANSWER](#))

**NEW QUESTION: 869**

The Project Manager is involved in acquiring the project team on a highway expansion project. She is presently discussing salary, working hours, travel, and benefits. What is the key tool she is utilizing?

- A. Staffing management plan
- B. Organizational chart
- C. Project team directory
- D. Negotiations

**Answer:** D ([LEAVE A REPLY](#))

Section: Mix Questions

**NEW QUESTION: 870**

The objective of duration compression includes all the following except:

- A. Do activities in parallel which would normally be done sequentially
- B. Do compression of tasks for the least incremental cost

- C. Do simulation to calculate distribution of probable reasons for the whole project
- D. Shorten the project schedule without impacting scope

**Answer: C ([LEAVE A REPLY](#))**

**NEW QUESTION: 871**

A project manager became aware of misunderstandings between a key stakeholder and a team member with regard to some of the features defined in the project scope. What should the project manager do?

- A. Work with both the team member and the key stakeholder to reach a consensus.
- B. Reconcile the team member to the key stakeholder's recommendation.
- C. Escalate the communication concerns to the project management office (PMO) and request that they take action
- D. Reconcile the key stakeholder to the team member's recommendation.

**Answer: A ([LEAVE A REPLY](#))**

**Valid PMP Dumps** shared by PrepPdf.com for Helping Passing PMP Exam! PrepPdf.com now offer the **newest PMP exam dumps**, the PrepPdf.com PMP exam **questions have been updated** and **answers have been corrected** get the **newest** PrepPdf.com PMP dumps with Test Engine here: <https://www.preppdf.com/PMI/PMP-prepaway-exam-dumps.html> (2045 Q&As Dumps, **40%OFF Special Discount: Exam-Tests**)

**NEW QUESTION: 872**

An agile leader notices that one team member consistently fails to complete the deliverables on time. The agile leader suspects that this team member does not have the proper training. What should the agile leader do?

- A. Review the definition of done (DoD) with the team so that everyone understands what the team must deliver in this sprint.
- B. Reassign the task to another team member and require the team member to complete training
- C. Use the retrospective meeting to remind the entire team that they must complete all deliverables in each sprint
- D. Speak directly with the team member about improvements and commit to an agreed-upon time frame.

**Answer: ([SHOW ANSWER](#))**

**NEW QUESTION: 873**

In a project, a Cost incentive contract has been awarded to a contractor with the following parameters:

Target cost: \$1,000,000 Target contractor fee: \$100,000 Cost benefit sharing ratio: 80%/20%  
Price ceiling: \$1,200,000

What is the Point of total assumption (PTA, Breakpoint) of the project?

- A. \$1,200,000
- B. \$1,000,000
- C. \$1,100,000
- D. \$1,125,000

**Answer: D ([LEAVE A REPLY](#))**

**NEW QUESTION: 874**

You are a project manager of ABC organization. Your project covers more than one department or technical area of expertise. Which type of organization is BEST for this project?

- A. MATRIX
- B. PROJECT EXPEDITOR
- C. FUNCTIONAL
- D. PROJECTIZED

**Answer: ([SHOW ANSWER](#))**

In this case where project covers more than one department or technical area of expertise a MATRIX organization is needed with representatives from each department or discipline is best. < li >PROJECTIZED: All organization is by projects. The project manager has total control of projects. Personnel are assigned and report to a project manager. < li >FUNCTIONAL: The organization is grouped by areas of specialization within different functional areas (e.g., sales, marketing etc.In this organization Project Manager has least power).

**NEW QUESTION: 875**

Risk responses reflect an organization's perceived balance between:

- A. risk taking and risk avoidance.
- B. varying degrees of risk.
- C. known risk and unknown risk.
- D. identified risk and analyzed risk.

**Answer: A ([LEAVE A REPLY](#))**

**NEW QUESTION: 876**

As a result of a new investor's participation stakeholders receive status reports and project information in a language with which they are unfamiliar. This causes confusion, and lessens project support What should the project manager do?

- A. Use conflict resolution techniques.
- B. Change the work performance information.
- C. Update the organizational process assets.
- D. Check the communications management plan.

**Answer: D ([LEAVE A REPLY](#))**

**NEW QUESTION: 877**

You recently took over the assignment for a project. The project charter and a preliminary scope statement have been developed. What is an appropriate next step for you?

- A. Develop management plans.
- B. Develop the risk register.
- C. Develop the project schedule.
- D. Get approval for the project management plan.

**Answer: A ([LEAVE A REPLY](#))**

#### **NEW QUESTION: 878**

The CPI of a project is 0.8, and you have limited budget - you are trying to procure a product from the supplier, in this situation you should:

- A. Try to crash the project - decreasing project schedule will decrease the costs
- B. Ask the supplier to provide a product of slightly lower quality since it will cost less
- C. Try to find out innovative means to lower costs
- D. Remove non-critical tasks from the project schedule

**Answer: C ([LEAVE A REPLY](#))**

#### **NEW QUESTION: 879**

Which process is usually a rapid and cost-effective means of establishing priorities for Plan Risk Responses?

- A. Identify Risks
- B. Plan Risk Management
- C. Perform Qualitative Risk Analysis
- D. Perform Quantitative Risk Analysis

**Answer: C ([LEAVE A REPLY](#))**

Section: Initiation

#### **NEW QUESTION: 880**

Two weeks into a new project, the project manager is involved in an accident. As a result another project manager must be appointed.

What should the new project manager update first?

- A. Project management plan
- B. Organizational process assets
- C. Project charter
- D. Resource calendars

**Answer: C ([LEAVE A REPLY](#))**

#### **NEW QUESTION: 881**

Which technique is used in Perform Quantitative Risk Analysis?

- A. Sensitivity analysis
- B. Probability and impact matrix

- C. Risk data quality assessment
- D. Risk categorization

**Answer: A ([LEAVE A REPLY](#))**

Section: Executing

**NEW QUESTION: 882**

A project is being delayed due to a large amount of rework caused by a quality problem that is impacting the critical path. What should the project manager do?

- A. Notify the project steering committee about the cause of the delay.
- B. Report the delay with rectifying actions to the project management office (PMO).
- C. Rebaseline the project schedule to absorb the delay.
- D. Report the delay with rectifying actions to the change control board (CCB) for review,

**Answer: B ([LEAVE A REPLY](#))**

**NEW QUESTION: 883**

What is the difference between expected monetary value and net present value?

- A. Expected value is the value it takes to recover your investment and net present value is the value of money.
- B. Expected value is the estimated value of risk response plans and net present value helps determine the value of investments.
- C. Expected value is the probability times impact of an opportunity and net present value is the benefits less costs over many time periods.
- D. Expected value is the estimated value of the work actually accomplished and net present value is the value of the work to be done.

**Answer: C ([LEAVE A REPLY](#))**

**NEW QUESTION: 884**

According to the PMI, which of the following are NOT true with regards to programs and projects?

- A. Programs are groups of project managed together
- B. Projects consists of one or more related programs
- C. Programs may involve a series of repetitive undertakings
- D. Programs often include elements of ongoing operations

**Answer: ([SHOW ANSWER](#))**

**NEW QUESTION: 885**

Which input to the Identify Stakeholders process provides information about internal or external parties related to the project?

- A. Procurement documents
- B. Communications plan
- C. Project charter
- D. Stakeholder register

**Answer: C (LEAVE A REPLY)**

Section: Initiation

**NEW QUESTION: 886**

Which of the following choices is a contract closure tool or technique?

- A. Contract plan
- B. Procurement plan
- C. Closure process
- D. Procurement audits

**Answer: D (LEAVE A REPLY)**

Section: Closing

**Valid PMP Dumps** shared by PrepPdf.com for Helping Passing PMP Exam! PrepPdf.com now offer the **newest PMP exam dumps**, the PrepPdf.com PMP exam **questions have been updated** and **answers have been corrected** get the **newest** PrepPdf.com PMP dumps with Test Engine here: <https://www.preppdf.com/PMI/PMP-prepaway-exam-dumps.html> (2045 Q&As Dumps, **40%OFF Special Discount: Exam-Tests**)

**NEW QUESTION: 887**

When defining the ground rules for a project team, the project manager observed that only two team members contributed to the discussion. As a result, the team ground rules favor these two team members.

What should the project manager have done to avoid this situation?

- A. Extend the meeting to allow everyone to speak
- B. Come to the meeting with suggested ground rules
- C. Set expectations for contributions ahead of the meeting
- D. Ask all team members to send new ideas prior to the meeting

**Answer: C (LEAVE A REPLY)**

**NEW QUESTION: 888**

A project team identifies the top four risks in a project, along with their probability and cost impact.

Risk	Probability	Cost impact
A	20%	US\$80,000
B	40%	US\$60,000
C	50%	US\$30,000
D	60%	US\$20,000

Based on this information, how much contingency reserve should the project manager request?

- A. US\$190,000
- B. US\$95,000
- C. US\$80,000

D. US\$67,000

**Answer: D (LEAVE A REPLY)**

Section: Planning

Explanation

**NEW QUESTION: 889**

The greatest degree of uncertainty is encountered during which phase of the project life cycle?

- A. Concept
- B. Planning
- C. Implementation
- D. Closeout

**Answer: A (LEAVE A REPLY)**

Section: Mix Questions

Explanation:

The greatest degree of uncertainty about the future is encountered during the concept phase or at the start of the project. The direction of the project is determined in this phase, and the decisions made have the greatest influence on scope, quality, time, and cost of the project.

**NEW QUESTION: 890**

Project managers have the highest level of authority and the most power in which type of organizational structure?

- A. Functional
- B. Balanced matrix
- C. Projectized
- D. Strong matrix

**Answer: C (LEAVE A REPLY)**

Project managers have the highest level of power and authority in a projectized organization. They also have high levels of power and authority in a strong matrix. However, a matrix organization is a blend of functional and projectized organizations. Therefore, the project manager does not have quite the same level of authority as they would in a projectized organization.

**NEW QUESTION: 891**

In a software project using an agile approach, there have recently been work overruns. After assessing the situation, the project manager concluded that the overruns are occurring because of insufficiently refined product backlog items.

What should the project manager do to correct this issue?

- A. Work with the sponsor to revise the product vision.
- B. Create a definition of ready (DoR) for the backlog items.
- C. Refine the product backlog items with the stakeholders.
- D. Discuss the issue with the service request manager.

**Answer:** ([SHOW ANSWER](#))

**NEW QUESTION: 892**

A project manager is tasked with proposing an implementation strategy for a project that will be delivered over a period of five years. What should the project manager do first?

- A. Review the lessons learned database
- B. Review the project budget to ensure adequate funding.
- C. Conduct a requirements gathering workshop.
- D. Develop the risk management plan.

**Answer:** A ([LEAVE A REPLY](#))

**NEW QUESTION: 893**

During a project's planning phase, a functional manager becomes anxious about the impact of the project on team morale and constantly reaches out the project manager with these concerns.

- A. Discuss the functional manager's concerns with the e sponsor.
- B. Review the project charter with the team to address the functional manager's concerns.
- C. Review the stakeholder engagement plan to ensure the functional manager's interests have been accurately recorded.
- D. Expand the project management information system, (PMIS) to allow members to communication their concerns to the functional manager.

**Answer:** A ([LEAVE A REPLY](#))

**NEW QUESTION: 894**

You are a project manager for a growing dairy farm. It offers its organic dairy products regionally and is expanding its operations to the West Coast. It is in the process of purchasing and leasing dairy farms to get operations underway. You are in charge of the network operations part of this project. An important deadline is approaching that depends on the successful completion of the testing phase. You've detected some problems with your hardware in the testing phase and discover that the hardware is not compatible with other network equipment. You take corrective action and exchange the hardware for more compatible equipment. Which of the following statements is true?

- A. This is not a corrective action because corrective action involves human resources, not project resources.
- B. Corrective action is not necessary in this case because the future project outcomes aren't affected.
- C. Corrective action serves as the change request to authorize exchanging the equipment.
- D. Corrective action is taken here to make sure the future project outcomes are aligned with the project management plan.

**Answer:** D ([LEAVE A REPLY](#))

Corrective action brings anticipated future project outcomes back into alignment with the project management plan. Since there is an important deadline looming that depends on a positive

outcome of this test, the equipment is exchanged so that the project plan and project schedule are not impacted.

**NEW QUESTION: 895**

A quality Issue that requires a change to the quality standard Is encountered In a project Currently, there Is no budget available for the required changes. What should the project manager do?

- A. Check the quality management plan
- B. Conduct a team brainstorming session to resolve the issue
- C. Document the issue in the scope management plan.
- D. Check the change management plan

**Answer: A ([LEAVE A REPLY](#))**

**NEW QUESTION: 896**

The change control board (CCB) has approved a change request to add a new component within a product. The operations manager discovers the change after its approval and complains that the implementation of the change will cause significant disruption to the production line.

What should the project manager do first?

- A. Formally acknowledge the operation manager's concerns and raise a new risk that the project may deliver late and over budget due to manufacturing difficulties.
- B. Meet with the operations manager to explain the background for the change and understand the operation manager's concerns about the change.
- C. Lead a root cause analysis workshop with the design team to identify the failures that led to the decision to add a component that was not compatible with the production line.
- D. Escalate the issue to the project sponsor, as the decision to add the component brings many benefits even though it will be disruptive to the production line.

**Answer: ([SHOW ANSWER](#))**

**NEW QUESTION: 897**

A \_\_\_\_\_ estimate prepared from layouts, sketches and flowsheets, should be accurate within (-10, +25%).

- A. Budget
- B. Parametric
- C. Bottom up.
- D. Definitive.
- E. Top down.

**Answer: ([SHOW ANSWER](#))**

**NEW QUESTION: 898**

Prior to the implementation of a system upgrade, a team member discovers a critical defect in the current system that must be fixed. What should the project manager do?

- A. Notify the operational manager, as this is not a project issue.
- B. Implement the fix and install it with the upgrade.
- C. Take no further actions since the project scope has been finalized.
- D. Notify the project sponsor and execute the Perform Integrated Change Control process.

**Answer: D (LEAVE A REPLY)**

**NEW QUESTION: 899**

During a project's planning session, the project team discussed selecting the required information to be included in the monthly progress report. This report will be produced in the Executing and Monitor and Controlling phases and will be used when communicating project progress to the client. Match the scenario on the left with the action on the right.

Team will measure the progress and convert it to equivalent dollar value	Value of Work Done
Team will measure project progress and compare it to base Project Management Institute schedule	Schedule Performance Index (SPI)
Team will show a graphical representation of actual progress, trend progress, and the planned progress	Earned Value (EV) Calculation
Team will show the project progress with measurement of cost & schedule	S-Curve

**Answer:**

Team will measure the progress and convert it to equivalent dollar value	Team will measure the progress and convert it to equivalent dollar value
Team will measure project progress and compare it to base schedule	Team will measure project progress and compare it to base schedule
Team will show a graphical representation of actual progress, trend progress, and the planned progress	Team will show the project progress with measurement of cost & schedule
Team will show the project progress with measurement of cost & schedule	Team will show a graphical representation of actual progress, trend progress, and the planned progress

**Explanation**

Team will measure the progress and convert it to equivalent dollar value

Team will measure project progress and compare it to base schedule

Team will show the project progress with measurement of cost & schedule

Team will show a graphical representation of actual progress, trend progress, and the planned progress

**NEW QUESTION: 900**

A project manager is worried that a key stakeholder is not participating in the project and has concluded that the final product is not as good as it could have been if the stakeholder had been more involved. Drag the scenario on the left to the correct risk response strategy on the right.

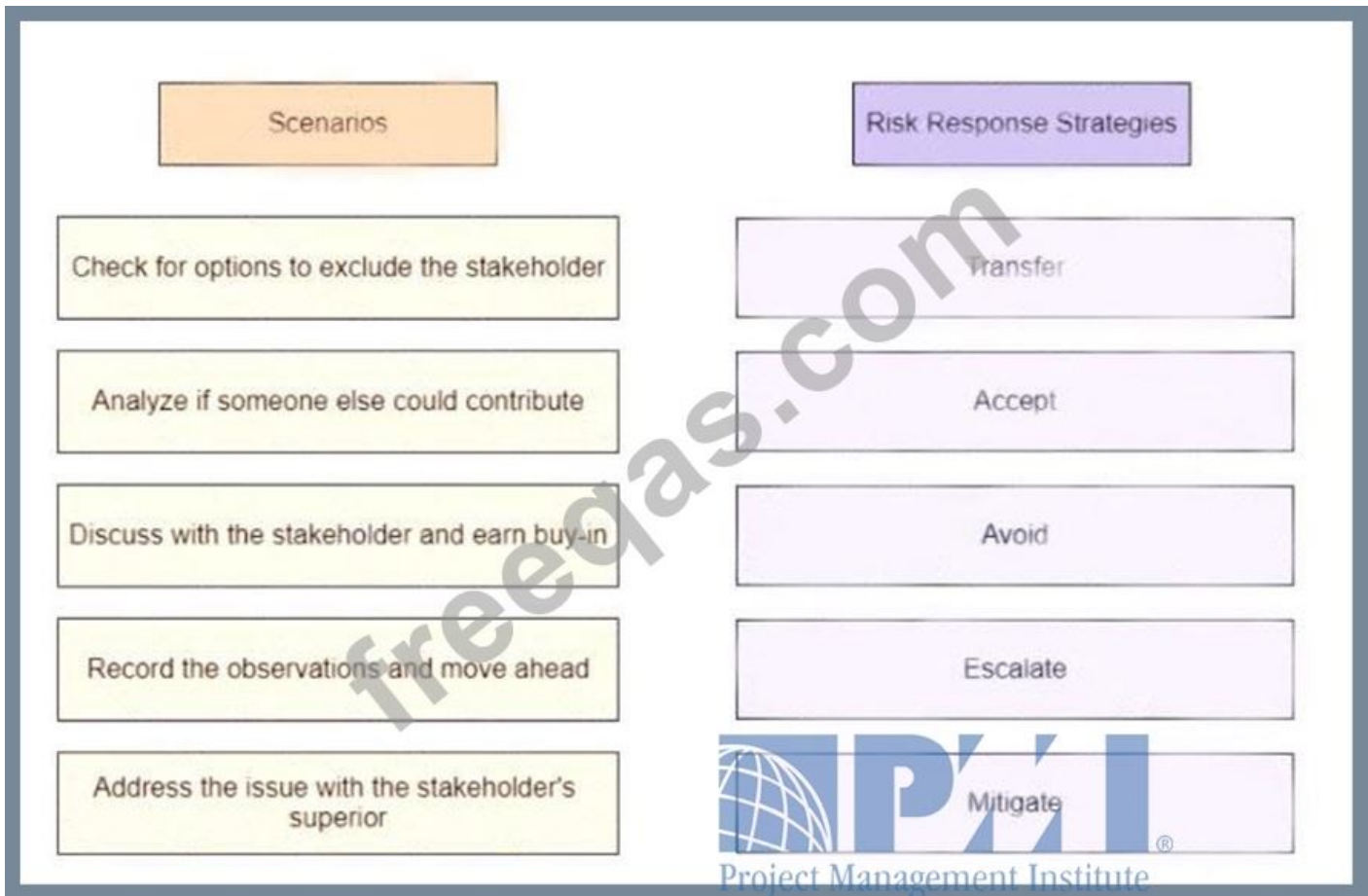

Answer:

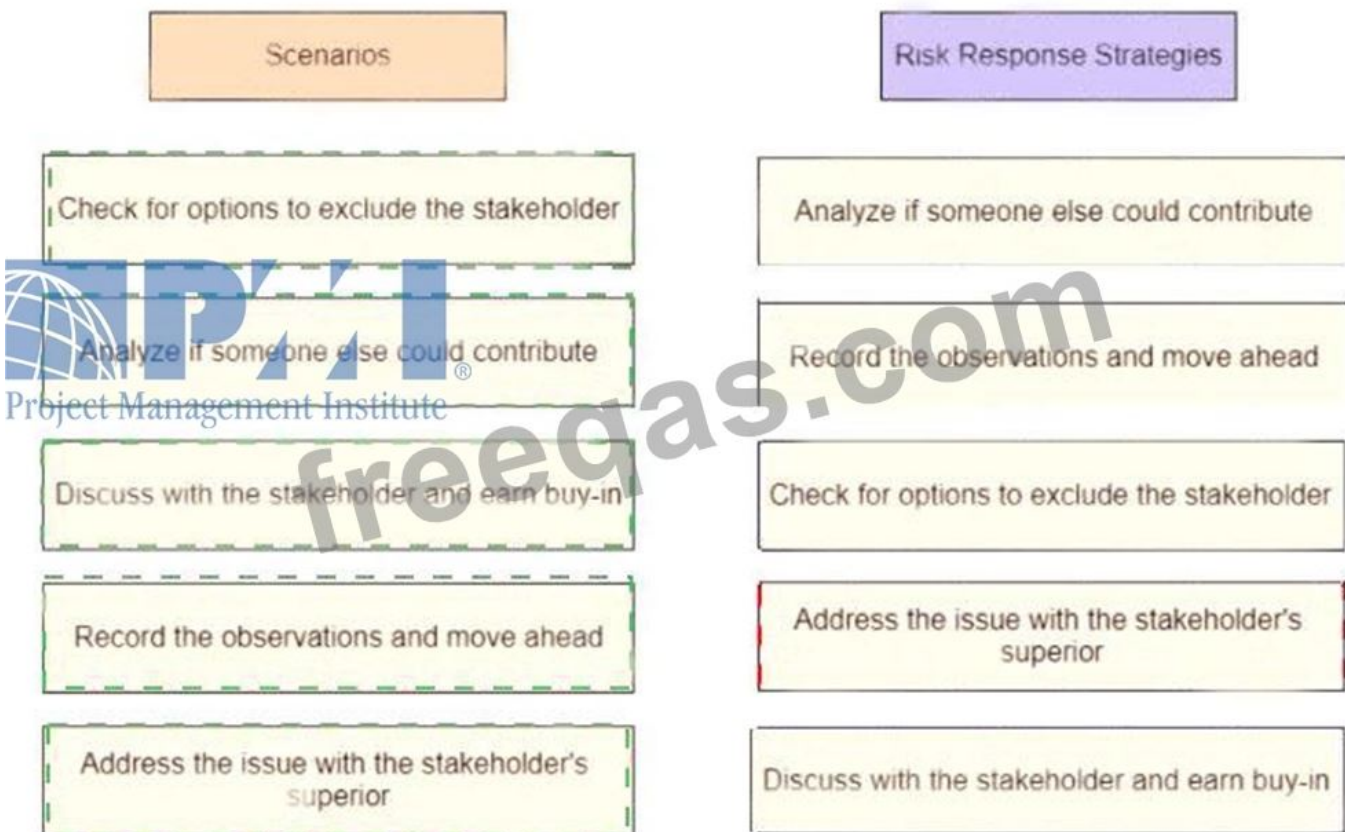



#### NEW QUESTION: 901

The risk response strategy in which the project team acts to reduce the probability of occurrence or impact of a risk is known as:

- A. share
- B. avoid
- C. exploit
- D. mitigate

**Answer: D** ([LEAVE A REPLY](#))

**Valid PMP Dumps** shared by PrepPdf.com for Helping Passing PMP Exam! PrepPdf.com now offer the **newest PMP exam dumps**, the PrepPdf.com PMP exam **questions have been updated** and **answers have been corrected** get the **newest** PrepPdf.com PMP dumps with Test Engine here: <https://www.preppdf.com/PMI/PMP-prepaway-exam-dumps.html> (2045 Q&As Dumps, **40%OFF** Special Discount: **Exam-Tests**)

#### NEW QUESTION: 902

Which tool or technique of Plan Quality involves comparing actual or planned practices to those of other projects to generate ideas for improvement and provide a basis by which to measure performance?

- A. Histogram
- B. Quality audits
- C. Benchmarking
- D. Performance measurement analysis

**Answer: C ([LEAVE A REPLY](#))**

Section: Planning

**NEW QUESTION: 903**

Sensitivity analysis is typically displayed as a/an:

- A. Decision tree diagram.
- B. Tornado diagram.
- C. Pareto diagram.
- D. Ishikawa diagram.

**Answer: ([SHOW ANSWER](#))**

Section: Closing

**NEW QUESTION: 904**

Activity resource requirements and the resource breakdown structure (RBS) are outputs of which Project Time Management process?

- A. Estimate Activity Resources
- B. Develop Schedule
- C. Control Schedule
- D. Define Activities

**Answer: A ([LEAVE A REPLY](#))**

**NEW QUESTION: 905**

A procurement manager needs to determine what type of contract to use for a construction project using a new supplier. What type of contract incorporates the highest risk?

- A. Cost plus award fee (CPAF)
- B. Cost plus incentive fee (CPIF)
- C. Cost plus percentage of cost (CPPC)
- D. Cost plus fixed fee (CPFF)

**Answer: ([SHOW ANSWER](#))**

Section: Planning

**NEW QUESTION: 906**

The financial closeout of a project dictates that:

- A. No follow-on work from this client is possible.
- B. No charge numbers have been overrun.
- C. All project funds have been spent.
- D. All of the other alternatives apply.
- E. No further charges can be made against the project.

**Answer: ([SHOW ANSWER](#))**

**NEW QUESTION: 907**

A project manager is planning a project that has 40 stakeholders. The project manager decides that all stakeholders will receive the same type of communications in order to minimize work for the project team and reduce costs. When the project manager reviews the communications management plan with the project management team, an experienced team member voices concerns about the communications decision.

Why might using the same type of communication for all 40 stakeholders be a concern?

- A. Because the team should be able to manage individual communications properly.
- B. Because the expected savings would be minimal
- C. Because different stakeholder needs are not being taken into consideration.
- D. Because some stakeholders might feel neglected.

**Answer: A ([LEAVE A REPLY](#))**

### **NEW QUESTION: 908**

An agile project team is working on an infrastructure product to be delivered incrementally over several iterations. Midway through the third iteration, the whole company is informed that the operating systems supported by the infrastructure will be terminated in the upcoming quarter. Several thousand machines will be impacted by this change.

What should the project manager do first?

- A. Add product backlog items to prioritize operating system stories.
- B. Schedule a session with stakeholders to understand the impact.
- C. Inform the product owner and request more project resources.
- D. Prioritize the upgrade of project machines with the IT department.

**Answer: B ([LEAVE A REPLY](#))**

### **NEW QUESTION: 909**

A difference between a Statement of work and a Scope statement is:

- A. The statement of work is prepared by the customer while the scope statement is developed by the project management team.
- B. A project scope statement can become a contract document; a statement of work cannot.
- C. The statement of work focuses on physical or technical matters, while the project scope statement focuses on a functional view.
- D. The project scope statement is in most projects developed before the statement of work is written.

**Answer: ([SHOW ANSWER](#))**

### **NEW QUESTION: 910**

A project manager is leading a project that is in an advanced stage. All high-level risks identified in the risk management plan have been resolved or are no longer a risk for the project. Only low-level risks remain. What should the project manager do now?

- A. Reduce the priority of project risks as all remaining risks are low-level
- B. Reclassify low-level risks as high-level risks

- C. Reevaluate identified risks and update the risk register
- D. Notify stakeholders that all high-level risks have been resolved

**Answer: C ([LEAVE A REPLY](#))**

**NEW QUESTION: 911**

A project manager has an agreement with a third-party supplier to deliver parts in six months. During the implementation phase, the project is cancelled. However, the supplier has already started work on the order.

What should the project manager do next?

- A. Direct the supplier to stop work immediately
- B. Update the procurement management plan
- C. Review the contract's termination clause
- D. Conduct a supplier performance evaluation

**Answer: D ([LEAVE A REPLY](#))**

**NEW QUESTION: 912**

An earthquake occurs at the site of a manufacturing plant construction project. This affects the entire project budget.

What type of reserve analysis should the project manager consider?

- A. Project
- B. Baseline
- C. Management
- D. Contingency

**Answer: D ([LEAVE A REPLY](#))**

**NEW QUESTION: 913**

Given that you are neighbors, you and the CEO of your company have established a friendly personal relationship. Recently your company appointed you project manager for a new project that is crucial to achieving next year's financial targets. Which type of power available to project managers might you be able to rely upon?

- A. Referent
- B. Reward
- C. Formal
- D. Expert

**Answer: ([SHOW ANSWER](#))**

Section: Mix Questions

Explanation:

Referent power is based on a less powerful person's identification with a more powerful person. This type of power is useful in terms of persuasion and helps the project manager exert influence over individuals from whom he or she needs support.

**NEW QUESTION: 914**

Which of the following best describes the difference between risk audits and risk reviews?

- A. Risk reviews are also called risk audits
- B. Risk reviews are performed on smaller projects, while risk audits are performed on larger projects
- C. Risk audits are more proactive responses to project risks, while risk reviews are more reactive responses to risks
- D. Risk audits should be performed by an outside party, while risk reviews are performed by the project team.

**Answer: (**[SHOW ANSWER](#)**)**

**NEW QUESTION: 915**

Which of the following represents the BEST process to accomplish resource planning?

- A. Identifying the available resources and allocate them to all activities in the current phase of the project.
- B. Identifying the required resources in the project charter
- C. Identifying the resources that performed past similar projects, and allocate them to all project activities
- D. Identifying the required resources and allocate them to all project activities.
- E. None of the above

**Answer: D (**[LEAVE A REPLY](#)**)**

**NEW QUESTION: 916**

You are a project manager responsible for constructing a new sports arena in preparation of the upcoming Olympics.

Construction began on the project a year ago. The stakeholder of the project want a status report on the performance of the project to the date.

Unfortunately, you are afraid of telling your stakeholders that your project is coming in over the budget and the cost change is required using the cost change control system. Which of the following tools were used to calculate the cost variance projection?

- A. Performance reports
- B. Analogous estimating
- C. Performance reviews
- D. Performance measurement analysis
- E. Trend analysis

**Answer: D (**[LEAVE A REPLY](#)**)**

**Valid PMP Dumps** shared by PrepPdf.com for Helping Passing PMP Exam! PrepPdf.com now offer the **newest PMP exam dumps**, the PrepPdf.com PMP exam **questions have been updated** and **answers have been corrected** get the **newest** PrepPdf.com PMP dumps with Test Engine here: <https://www.preppdf.com/PMI/PMP-prepaway-exam-dumps.html> (2045 Q&As Dumps, **40%OFF Special Discount: Exam-Tests**)

**NEW QUESTION: 917**

Due to a company merger and acquisition process, the main stakeholder of a critical project has been changed. This new stakeholder complains that they were unaware of a delay on the project of which the rest of the stakeholders were aware. All the communications about the project are shared via email at the start of every week.

How should the project manager address this situation?

- A. Share the communications management plan with the new stakeholder
- B. Suggest that the new stakeholder review the project status before the next board meeting
- C. Send evidence to the new stakeholder that the project's status was sent according to the schedule
- D. Discuss project requirements with the new stakeholder, and update the communications management plan.

**Answer:** ([SHOW ANSWER](#))

**NEW QUESTION: 918**

A project team has finished participating in an iterative product increment planning session. After the planning session, the team returns with a list of features to deliver.

How should the project manager ensure the product increments deliver the anticipated requirements?

- A. Appoint a dedicated product manager for the duration of the release
- B. Have the customer approve the product increment features.
- C. Ensure every user story has acceptance criteria.
- D. Track business outcomes for planned user stories.

**Answer:** D ([LEAVE A REPLY](#))

**NEW QUESTION: 919**

Which of the following is an input to the Qualitative Risk Analysis process?

- A. Risk register
- B. Risk data quality assessment
- C. Risk categorization
- D. Risk urgency

**Answer:** A ([LEAVE A REPLY](#))

Section: Initiation

**NEW QUESTION: 920**

A company uses a management technique that employs quality assurance techniques to continuously improve all processes. This is called:

- A. Ishikawa Diagrams
- B. Kaizen
- C. Inspection
- D. Just In Time Management

**Answer: B (LEAVE A REPLY)**

Kaizen is a Japanese word that means "improvement" - and it's also a management technique that helps your company use problem-solving to constantly find new ways to improve. Kaizen focuses on making small improvements and measuring their impact. It's a philosophy that guides management, rather than a particular way of doing quality assurance.

**NEW QUESTION: 921**

To account for uncertainty in a schedule, reserve analysis may be used. All the following are examples of contingency reserves EXCEPT \_\_\_\_\_

- A. Fixed number of work periods
- B. Percent of the estimated activity duration
- C. Buffers
- D. Productivity metrics

**Answer: D (LEAVE A REPLY)**

Section: Mix Questions

Explanation:

Duration estimates may include contingency reserves, and contingency should be identified clearly in schedule documentation. They are built into the overall project schedule to account for uncertainty. They also may be developed using quantitative analysis methods. When more information is known about the project, the contingency reserve may be used, reduced, or eliminated.

**NEW QUESTION: 922**

The project is progressing well but has begun to experience resource conflicts with people who are being pulled from the project by functional management for other work. What role will typically help resolve these resource issues?

- A. Senior management
- B. Functional management
- C. Project management
- D. Sponsor

**Answer: A (LEAVE A REPLY)**

Section: Mix Questions

**NEW QUESTION: 923**

A quality manager informs a project manager that their team is performing tasks that are not part of the project management plan. A project team member notes that a task was added after a discussion with the customer.

What should the project manager do?

- A. Review the change management plan.
- B. Invoice the customer for the additional work.
- C. Request a technical assessment of the customer's request.
- D. Reward the team member for visualizing customer requests.

**Answer: (SHOW ANSWER)**

Section: Monitoring and Controlling

#### **NEW QUESTION: 924**

When should the project expeditor form of organization be used?

- A. When the organization's primary source of revenue is derived from projects.
- B. When a project's cost and importance are relatively low.
- C. When the project manager has a lot of responsibility and accountability.
- D. When the project is extremely important to the organization.

**Answer: B (LEAVE A REPLY)**

#### **NEW QUESTION: 925**

You know that PV = 470, AC = 430, EV = 480, EAC = 500, and BAC = 525. What is VAC?

- A. 25
- B. 30
- C. 20
- D. 70

**Answer: A (LEAVE A REPLY)**

VAC is calculated this way:  $VAC = BAC - EAC$ . Therefore,  $525 - 500 = 25$ .

#### **NEW QUESTION: 926**

A company is implementing a project with team members who are located in different countries and time zones. Performance assessments show that team performance is low because the team doesn't have a common understanding about task distribution. What should the project manager do?

- A. Perform team-building activities
- B. Revisit the communications management plan
- C. Review and reassign tasks
- D. Colocate the team members

**Answer: (SHOW ANSWER)**

#### **NEW QUESTION: 927**

Who determines which dependencies are mandatory during the Sequence Activities process?

- A. Project manager
- B. External stakeholders
- C. Internal stakeholders
- D. Project team

**Answer: D** ([LEAVE A REPLY](#))

Section: Executing

#### **NEW QUESTION: 928**

Prototype development may be used as a tool for which of the following risk response strategies?

- A. Avoid
- B. Accept
- C. Mitigate
- D. Exploit

**Answer: C** ([LEAVE A REPLY](#))

Section: Initiation

#### **NEW QUESTION: 929**

A critical project is in the execution stage. The budget is strict, and managing the project to triple constraints is of high importance. A team member informs the project manager that there could be a significant cost overrun.

What should the project manager do next?

- A. Capture this in the issue log: and monitor the cost overrun until project closure
- B. Review risk threshold to determine if it is an allowable cost overrun percentage.
- C. Ensure there are enough reserves to cover the cost overrun.
- D. Investigate the reasons for the cost overrun.

**Answer: B** ([LEAVE A REPLY](#))

#### **NEW QUESTION: 930**

Situational leadership as defined by Hersey and Blanchard consists of the stages

- A. Must-be requirements, one-dimensional requirements, attractive requirements
- B. Direct style, instrumental style, relational style.
- C. Directing, supporting, coaching, delegating.
- D. Acquisition stage, learning stage, performance stage, exhaustion stage

**Answer: C** ([LEAVE A REPLY](#))

#### **NEW QUESTION: 931**

A critical resource has resigned, putting a multidisciplinary project at risk. Upper management is putting pressure on the project manager to assign the rest of their project tasks to another identified resource. In this scenario, what should the project manager do first?

- A. Assign the tasks to the new resource.
- B. Update the resource breakdown structure

- C. Follow the integrated change control process
- D. Revise the project management plan.

**Answer: C (LEAVE A REPLY)**

**Valid PMP Dumps** shared by PrepPdf.com for Helping Passing PMP Exam! PrepPdf.com now offer the **newest PMP exam dumps**, the PrepPdf.com PMP exam **questions have been updated** and **answers have been corrected** get the **newest** PrepPdf.com PMP dumps with Test Engine here: <https://www.preppdf.com/PMI/PMP-prepaway-exam-dumps.html> (2045 Q&As Dumps, **40%OFF Special Discount: Exam-Tests**)

**NEW QUESTION: 932**

Which of the following BEST describes a mutually binding legal agreement that obligates the seller to provide specified products / services and obligates the buyer to pay the seller?

- A. Contract management plan
- B. NDA agreements
- C. Contract
- D. None of the choices are correct
- E. Procurement document package

**Answer: C (LEAVE A REPLY)**

**NEW QUESTION: 933**

What process determines which risks might affect the project?

- A. Qualitative risk analysis
- B. Identify Risks
- C. Plan Risk Management
- D. Quantitative risk analysis

**Answer: B (LEAVE A REPLY)**

Section: Initiation

**NEW QUESTION: 934**

The project manager is given two teams that are restricted to working five days per week. The initial calculations give a project timeline of two weeks. However, one of the teams will only be available for two and a half days during week one due to a previous commitment. The timeline is revised to three weeks.

What optimization technique was used to revise the timeline?

- A. Resource smoothing
- B. Critical chain management
- C. Critical path management
- D. Resource leveling

Answer: ([SHOW ANSWER](#))

**NEW QUESTION: 935**

The sum of the products and services to be provided as a project is called:

- A. Project charter
- B. Data items
- C. Scope
- D. Deliverables

Answer: D ([LEAVE A REPLY](#))

**NEW QUESTION: 936**

During a project's planning session, the project team discussed selecting the required information to be included in the monthly progress report. This report will be produced in the Executing and Monitor and Controlling phases and will be used when communicating project progress to the client. Match the scenario on the left with the action on the right.

Team will measure the progress and convert it to equivalent dollar value	Value of Work Done
Team will measure project progress and compare it to base schedule	Schedule Performance Index (SPI)
Team will show a graphical representation of actual progress, trend progress, and the planned progress	Earned Value (EV) Calculation
Team will show the project progress with measurement of cost & schedule	S-Curve

Answer:

Team will measure the progress and convert it to equivalent dollar value

Team will measure project progress and compare it to base schedule

Team will show a graphical representation of actual progress trend progress, and the planned progress

Team will show the project progress with measurement of cost & schedule

Team will measure the progress and convert it to equivalent dollar value

Team will measure project progress and compare it to base schedule

Team will show the project progress with measurement of cost & schedule

Team will show a graphical representation of actual progress, trend progress, and the planned progress

**NEW QUESTION: 937**

The project planning is progressing on budget. The Project Manager and the team meet regularly and are ready to begin updating the project planning documents with a major scope change. What input into the planning process will help the team the most?

- A. WBS
- B. Risk list
- C. Network diagram
- D. Project management plan

**Answer: A (LEAVE A REPLY)**

**NEW QUESTION: 938**

A project team identifies the top four risks in a project, along with their probability and cost impact.

Risk	Probability	Cost Impact
A	20%	US\$80,000
B	40%	US\$60,000
C	50%	US\$30,000
D	60%	US\$20,000

Based on this information, how much contingency reserve should the project manager request?

- A. US\$95,000
- B. US\$80,000

C. US\$67,000

D. US\$190,00

Answer: ([SHOW ANSWER](#))

**NEW QUESTION: 939**

Which process requires implementation of approved changes?

A. Direct and Manage Project Execution

B. Monitor and Control Project Work

C. Close Project or Phase

D. Perform Integrated Change Control

Answer: ([SHOW ANSWER](#))

**NEW QUESTION: 940**

A stakeholder requests a change that will add value to a product currently under development.

The change control board (CCB) rejects this request.

What should the project manager do first?

A. Revise the issue log and inform the stakeholder.

B. Evaluate the impact of this decision and update the risk

C. Assess the impact of this decision on it\* stakeholders expectations and update the stakeholder engagement assessment matrix.

D. Update the change log and inform the stakeholder

Answer: A ([LEAVE A REPLY](#))

**NEW QUESTION: 941**

An information technology (IT) team is responsible for the validation and release of a product developed by the agile development team. Due to other priorities for the IT team, the releases are delayed. What action should the project manager take?

A. Escalate the issue from the IT team to management and get the validation prioritized

B. Request the IT team to immediately release the product and then validate the features

C. Work with the IT team to prioritize the validation and release of the new features

D. Deliver the features when the IT team is able to validate them

Answer: ([SHOW ANSWER](#))

**NEW QUESTION: 942**

An experienced project manager is building the base cost management plan of a project. During this process, the project manager is struggling to receive input from a couple of the stakeholders. The issue has been escalated to the sponsor but input has still not been received.

What should the project manager do to complete the cost estimate?

A. Keep pushing for the information through all communication channels.

B. Look for other ways to estimate costs such as using previous similar projects' costs.

C. Increase the contingency budget to cover unexpected costs.

D. Report the lack of stakeholder engagement to the stakeholders' bosses.

**Answer: B ([LEAVE A REPLY](#))**

**NEW QUESTION: 943**

A key project team member takes a leave of absence with an unknown expected return date, leading to a possible delay in the project delivery schedule. How can the project manager help the team to deliver on an adaptive project?

A. Take on the work of the team member and ask the team to provide support wherever possible.

B. Engage the remaining team members to identify work dependencies and reprioritize the deliverables for upcoming delivery iterations.

C. Add a risk to the risk register and get approval from the project sponsor to allocate reserve contingency.

D. Discuss the delays with the functional manager and ask them to assign overtime to the rest of the team.

**Answer: B ([LEAVE A REPLY](#))**

**NEW QUESTION: 944**

The cumulative CPI has been shown to be relatively stable after what percentage of project completion?

A. 5% to 10%

B. 15% to 20%

C. 25% to 35%

D. 50% to 75%

**Answer: B ([LEAVE A REPLY](#))**

Explanation/Reference:

Explanation:

The CPI has been proven to be an accurate and reliable forecasting tool. Researchers have found that the cumulative CPI does not change by more than 10% once a project is approximately 20% complete. The CPI provides a quick statistical forecast of final project costs.

**NEW QUESTION: 945**

By using Project Risk Management techniques, project managers can develop strategies that do all but which of the following:

A. identify risks, their impact(s), and any appropriate responses

B. provide a rational basis for better decision making

C. Significantly reduce project risks

D. None of the other alternatives apply .

E. eliminate project risks

**Answer: ([SHOW ANSWER](#))**

**NEW QUESTION: 946**

The Project Manager is creating an estimate for building a company WAN (wide area network). It is something that is new to the Project Manager and his team, and they want to make sure all the work of the project is covered. They decide to create a bottom-up estimate. All of the following are advantages of this type of estimate except...

- A. It provides team buy-in when they help create it
- B. It takes a great amount of time to create
- C. It has a greater degree of accuracy because of the detail at which it was created
- D. It provides supporting detail of the estimate

**Answer: B (LEAVE A REPLY)**

**Valid PMP Dumps** shared by PrepPdf.com for Helping Passing PMP Exam! PrepPdf.com now offer the **newest PMP exam dumps**, the PrepPdf.com PMP exam **questions have been updated** and **answers have been corrected** get the **newest** PrepPdf.com PMP dumps with Test Engine here: <https://www.preppdf.com/PMI/PMP-prepaway-exam-dumps.html> (2045 Q&As Dumps, **40%OFF Special Discount: Exam-Tests**)

#### **NEW QUESTION: 947**

The control chart is a tool used primarily to help\_\_\_\_\_

- A. Monitor process variation over time
- B. Measure the degree of conformance
- C. Determine whether results conform
- D. Determine whether results conform to requirements

**Answer: A (LEAVE A REPLY)**

Section: Mix Questions

Explanation:

Used to monitor process variation and to detect and correct changes in process performance, the control chart helps people understand and control their processes and work. It enables the project manager, along with appropriate stakeholders, to identify points where corrective action can be taken to prevent unnatural performance.

#### **NEW QUESTION: 948**

Which schedule network analysis technique modifies the project schedule to account for limited resources?

- A. Human resource planning
- B. Rolling wave planning
- C. Critical chain method
- D. Fast tracking

**Answer: C (LEAVE A REPLY)**

**NEW QUESTION: 949**

The salvage value of an asset is:

- A. The costs that have been sunk into the project to date.
- B. The value of the scrap metal if a new asset were taken to a scrap yard.
- C. The value that an asset has on the books after one year of depreciation.
- D. Both 1) The value of the scrap metal if a new asset were taken to a scrap yard and 2) The expected cash value at the end of an assets useful life.
- E. The expected cash value at the end of an assets useful life.

**Answer:** ([SHOW ANSWER](#))

**NEW QUESTION: 950**

As head of the project management office, you need to focus on those items where risk responses can lead to better project outcomes. One way to help you make these decisions is to \_\_\_\_\_

- A. Use a probability and impact matrix
- B. Assess trends in perform quantitative risk analysis results
- C. Prioritize risks and conditions
- D. Assess trends in perform qualitative risk analysis results

**Answer: A** ([LEAVE A REPLY](#))

Explanation/Reference:

Explanation:

The probability and impact matrix can be used to classify risks according to their level of impact and to prioritize them for future quantitative analyses and responses based on their rating. Typically these risk rating rules are specified by the organization in advance of the project. The matrix specifies combinations of probability and impact that lead to rating the risks as low, moderate, or high priority.

**NEW QUESTION: 951**

What documents the characteristics of the product or service that the project was undertaken to build.

- A. Resource plan
- B. Project description
- C. Scope statement
- D. Project charter

**Answer: B** ([LEAVE A REPLY](#))

Project description documents the characteristics of the product or service that the project was undertaken to build.

**NEW QUESTION: 952**

Life cycle costing is the total cost to the customer for the acquisition and ownership over its full life. Life cycle costing categories include the cost of \_\_\_\_\_, \_\_\_\_\_, and \_\_\_\_\_.

- A. Production, operations, maintenance.
- B. None of the other alternatives apply
- C. R & D, production, operation and support.
- D. Acquisition, operations, maintenance.
- E. R & D, maintainability, operation and support.

**Answer: C ([LEAVE A REPLY](#))**

**NEW QUESTION: 953**

A retail expansion project is going relatively well, but the people doing work on the project are complaining that it seems as though they answer to two bosses on the project, each with conflicting agendas. This is an example of what type of project environment?

- A. Tight matrix
- B. Matrix
- C. Projectized
- D. Functional

**Answer: B ([LEAVE A REPLY](#))**

**NEW QUESTION: 954**

Which is a tool or technique used in Define Scope?

- A. Product analysis
- B. Templates, forms, and standards
- C. Change requests
- D. Project assumptions

**Answer: A ([LEAVE A REPLY](#))**

**NEW QUESTION: 955**

A project manager for a large multiyear industrial project has a project with diversified stakeholders from various geographical areas. Recently, the project manager encountered an issue with stakeholder engagement Which two tools should the project manager use to determine the underlying reason for why engagement is not having the planned effect? (Choose two)

- A. Issue log
- B. Ishikawa diagrams
- C. Communications management plan
- D. Five whys
- E. Open-space meetings

**Answer: B,D ([LEAVE A REPLY](#))**

**NEW QUESTION: 956**

A Project Manager has completed the Scope Definition process. The customer and sponsor have shortened the schedule by four weeks and decided that the work breakdown structure will be excluded.

The Project Manager informs the customer and sponsor that this process creates the work breakdown structure for their project. Which answer best explains why the WBS is so important to a project?

- A. It provides a hierarchical diagram of the project
- B. It is the foundation of the project
- C. It provides templates that can be reused on other projects
- D. It helps in team commitment to the project

**Answer: B ([LEAVE A REPLY](#))**

Section: Mix Questions

#### **NEW QUESTION: 957**

During the closing of a complex project that includes several stakeholders, the project manager initiates a satisfaction evaluation. The contact information for one of the stakeholders is inaccurate.

What should the project manager do to obtain accurate stakeholder information?

- A. Contact the stakeholders individually.
- B. Ask the sponsor for the updated stakeholder information.
- C. Review the stakeholder engagement plan.
- D. Refer to the stakeholder register.

**Answer: ([SHOW ANSWER](#))**

Section: Closing

#### **NEW QUESTION: 958**

According to Herzberg, which of the following is a motivational factor?

- A. Hygiene needs
- B. Working conditions
- C. Pay
- D. Vacation time
- E. Achievement

**Answer: E ([LEAVE A REPLY](#))**

#### **NEW QUESTION: 959**

Which of the following best describes risks that arise as a direct implementation of implementing a risk response?

- A. Residual risks
- B. Secondary risks
- C. Contingency risks
- D. Tertiary risks

**Answer: ([SHOW ANSWER](#))**

#### **NEW QUESTION: 960**

Cost of quality (COQ) refers to total cost of/to:

- A. All efforts related to quality.
- B. Product inspection activities.
- C. Maintain plan quality.
- D. Perform quality control.

**Answer: B (LEAVE A REPLY)**

Section: Monitoring and Controlling

#### **NEW QUESTION: 961**

Configuration management does all of the following except:

- A. Control changes to functional and physical characteristics of an item or a system
- B. Defines the steps by which official project documents may be changed
- C. Audits items and systems to ensure conformance to requirements
- D. Record and report changes to any functional and physical characteristics of an item or a system

**Answer: B (LEAVE A REPLY)**

**Valid PMP Dumps** shared by PrepPdf.com for Helping Passing PMP Exam! PrepPdf.com now offer the **newest PMP exam dumps**, the PrepPdf.com PMP exam **questions have been updated** and **answers have been corrected** get the **newest** PrepPdf.com PMP dumps with Test Engine here: <https://www.preppdf.com/PMI/PMP-prepaway-exam-dumps.html> (2045 Q&As Dumps, **40%OFF Special Discount: Exam-Tests**)

#### **NEW QUESTION: 962**

All of the following statements regarding management reserves are true EXCEPT:

- A. Management reserve describes the difference between the maximum funding and the end of the cost baseline
- B. Any gap at the end of a project between the funds allocated and the cost baseline and cash flow mounts shows the amount of the management reserve that was not used.
- C. Management reserves are not part of the project cost baseline but are included in the budget for the project
- D. Management reserves are distributed as part of the budget and are part of earned value calculations
- E. Management reserves are allowance for unplanned, but potentially require to changes to the project scope and cost

**Answer: D (LEAVE A REPLY)**

#### **NEW QUESTION: 963**

A project is scheduled to end in 2 weeks. The team is expected to continue working long hours and is showing signs of weariness and fatigue. What should the project manager do to encourage the team?

- A. Add new team members to help the project finalization
- B. Schedule working lunch meetings until the project is complete
- C. Initiate rewards and incentives according to assessment results
- D. Schedule training courses to enhance team performance

**Answer:** ([SHOW ANSWER](#))

#### **NEW QUESTION: 964**

A new project manager joins a project in its execution phase that is behind schedule and over budget. A brief first analysis reveals that this is due to a dissatisfied stakeholder. After further review of project documentation, the manager determines that this stakeholder has high power and high interest in the project.

The project manager decides to meet with the stakeholder to review the stakeholder's expectations.

After the meeting, what should the project manager do first?

- A. Regularly email the stakeholder.
- B. Attempts to meet some of the stakeholder's
- C. Update the stakeholder engagement plan.
- D. Keep the stakeholder continuously informed on every step of the project.

**Answer:** B ([LEAVE A REPLY](#))

#### **NEW QUESTION: 965**

A project manager is asked to select a contract type for a new software development project that has complete, detailed requirements. Which is the BEST contract to choose?

- A. Fixed price (FP)
- B. Cost plus fixed fee (CPFF)
- C. Time and material (T&M)
- D. Cost reimbursable (CR)

**Answer:** ([SHOW ANSWER](#))

#### **NEW QUESTION: 966**

Which enterprise environmental factors may influence Plan Schedule Management?

- A. Cultural views regarding time schedules and professional and ethical behaviors
- B. Risk control procedures and the probability and impact matrix
- C. Resource availability and organizational culture and structure
- D. Historical information and change control procedures

**Answer:** ([SHOW ANSWER](#))

#### **NEW QUESTION: 967**

Projects are undertaken by an organization to support the:

- A. Product performance.
- B. Collective capabilities.
- C. Budget process.
- D. Organizational strategy.

**Answer:** ([SHOW ANSWER](#))

**NEW QUESTION: 968**

Different types of project phases are used on projects, and each phase culminates in the completion of at least one deliverable. The high-level nature of these phases means they are an element of the project life cycle. Some phases start before others complete. If this approach is followed, it may result in\_\_\_\_\_.

- A. An increase in the number of issues
- B. Increasing the schedule
- C. The need for a CCB
- D. More rework

**Answer: D** ([LEAVE A REPLY](#))

Explanation/Reference:

Explanation:

The question is an example of an overlapping relationship between phases. It is used to compress the schedule through fast tracking as an example. By overlapping phases more resources may be needed, risks may increase, and more rework may result if a significant phase progresses before accurate information is available from the previous phase.

**NEW QUESTION: 969**

As a member of an organizational change management team, a project manager must pass on any changes to the project team The project manager needs to avoid any misunderstandings or resistance to help ensure that the project team will support any organizational change What should the project manager do?

- A. Influence the team to communicate any changes
- B. Check with the
- C. Conduct meetings with resistant members to facilitate smooth project implementation
- D. Meet with the team on a regular basis to ensure they are aware of changes.

**Answer: D** ([LEAVE A REPLY](#))

**NEW QUESTION: 970**

The project planning for the trade show is progressing on schedule. The Project Manager and the team are meeting to begin cost estimating. The sponsor has said that estimates must be very accurate. Which of the following estimating techniques will provide the most accuracy?

- A. Bottom-up estimating
- B. Parametric estimating

C. Analogous estimating

D. Cost estimating

**Answer: A ([LEAVE A REPLY](#))**

**NEW QUESTION: 971**

A project manager managing a cross-cultural virtual project team across several time zones should be concerned about the impacts of which communication technology factor?

A. Sensitivity of information

B. Ease of use

C. Urgent information need

D. Project environment

**Answer: D ([LEAVE A REPLY](#))**

**NEW QUESTION: 972**

A project manager discusses a project's status with the customer. The customer expresses the need for a new system that is not part of the current project scope.

What should the project manager do next?

A. Inform the project sponsor of the cost and schedule impacts,

B. Update the requirements management plan.

C. Update the project scope baseline and work breakdown structure (WBS).

D. Evaluate the customer's needs as part of the Perform Integrated Change Control process,

**Answer: D ([LEAVE A REPLY](#))**

**NEW QUESTION: 973**

Which of the following is a statistical concept that calculates the average outcome when the future includes scenarios that may or may not happen?

A. Sensitivity analysis

B. Three-point estimate

C. Modeling and simulation

D. Expected monetary value analysis

**Answer: D ([LEAVE A REPLY](#))**

Section: Closing

**NEW QUESTION: 974**

One of the service providers on a complex project has been facing resource availability problems over the last six months. However, the service provider has assured the project manager that the deliverables will be on time.

How should the project manager address this situation?

A. Update the issue log.

B. Perform a qualitative risk analysis.

C. Perform a root cause analysis.

D. Implement a risk response plan.

Answer: ([SHOW ANSWER](#))

**NEW QUESTION: 975**

You are in the process of completing and selling each contract, and resolving any open items. All of the following are inputs you require EXCEPT:

- A. Contract documentation
- B. Contract closure procedure
- C. Performance reports
- D. Procurement management plan
- E. Contract management plan

Answer: C ([LEAVE A REPLY](#))

**NEW QUESTION: 976**

Which of the following process is involved in making needed information available to project stakeholders in a timely manner?

- A. Communications planning
- B. Information distribution
- C. Manage stakeholders
- D. Performance reporting

Answer: ([SHOW ANSWER](#))

**Valid PMP Dumps** shared by PrepPdf.com for Helping Passing PMP Exam! PrepPdf.com now offer the **newest PMP exam dumps**, the PrepPdf.com PMP exam **questions have been updated** and **answers have been corrected** get the **newest** PrepPdf.com PMP dumps with Test Engine here: <https://www.preppdf.com/PMI/PMP-prepaway-exam-dumps.html> (2045 Q&As Dumps, **40%OFF Special Discount: Exam-Tests**)

**NEW QUESTION: 977**

You are a Project Manager, and you want your team to use (WBS) in cost estimation developed for your project. Which techniques are you most likely to use?

- A. Bottom up estimating
- B. Expert Judgment
- C. Numerical estimating
- D. Analogous estimating

Answer: ([SHOW ANSWER](#))

**NEW QUESTION: 978**

All the following statements are true about Analogous Estimating except:

- A. Also called top-down estimating
- B. Use Mathematical Models to predict project costs
- C. Used to estimate total project costs without detailed information about project.
- D. Actual cost of a previous small project is used for creating estimates

**Answer: B ([LEAVE A REPLY](#))**

**NEW QUESTION: 979**

A project team member has been having a big disagreement with another team member for over two months when the other team members become involved. The issues are complex, but you have specific experience in the area and know what needs to be done. The BEST choice would be to:

- A. Ask the other team members to stay out of the issue.
- B. Bring the team together and work out the issue to a win-win solution.
- C. Make the decision yourself.
- D. Strive for fair resolution of the issue.

**Answer: D ([LEAVE A REPLY](#))**

**NEW QUESTION: 980**

A project manager in a cross-functional organization needs to inform the department manager of the number and type of resources required, and the length of time they will be needed. What should the project manager use to present this resource information?

- A. Resource assignments
- B. Resource histogram
- C. Responsibility assignment matrix (RAM)
- D. Project organization chart

**Answer: B ([LEAVE A REPLY](#))**

Section: Initiation

**NEW QUESTION: 981**

All of the following are considered schedule network analysis techniques EXCEPT:

- A. Critical path method
- B. What-if analysis
- C. Critical chain method
- D. PDM/ ADM
- E. Resource leveling

**Answer: D ([LEAVE A REPLY](#))**

**NEW QUESTION: 982**

The project team is developing rules for reporting status on the project in the communication management plan. The majority of their activities are greater than three reporting periods long. Which format is best to use in this case?

- A. Fixed formula progress reporting
- B. Forecast reporting
- C. Earned value
- D. Weighted milestone

**Answer: D** ([LEAVE A REPLY](#))

**NEW QUESTION: 983**

Which type of dependency used in the Sequence Activities process is sometimes referred to as preferred logic, preferential logic, or soft logic?

- A. Internal
- B. External
- C. Discretionary
- D. Mandatory

**Answer: C** ([LEAVE A REPLY](#))

Section: Monitoring and Controlling

**NEW QUESTION: 984**

Drag the organizational characteristics on the left to the correct scenario on the right Check the answer below.

**Answer:**

See the explanation image

Scenario

Change tolerant

Roadblock to achieving changes

Change associated with agile

Appetite for change by leading by example

**NEW QUESTION: 985**

A project manager is struggling to obtain participation from key stakeholders who do not usually attend project meetings. What should the project manager do?

- A. Set clear meeting expectations by sharing agendas in advance

- B. Escalate the issue to senior management
- C. Reschedule meetings to align with the stakeholders' availability
- D. Distribute the communications management plan

**Answer:** ([SHOW ANSWER](#))

**NEW QUESTION: 986**

All the following are project baselines that are generally part of the project management plan EXCEPT \_\_\_\_\_.

- A. Technical
- B. Scope
- C. Time
- D. Cost

**Answer: A** ([LEAVE A REPLY](#))

Explanation/Reference:

Explanation:

Scope, time, and cost are examples of project baselines to be part of the project management plan.

**NEW QUESTION: 987**

ZULFI is a project manager who manages equipment installations in an automobile manufacturing project.

Early in the planning process, top management has asked him to generate ideas for improvement and to provide a basis by which to measure performance. Adel is most likely to use:

- A. Control charts
- B. Bench-marking
- C. Pareto charts
- D. Scatter diagrams

**Answer: B** ([LEAVE A REPLY](#))

**NEW QUESTION: 988**

An electronic component had a reliability of 0.90. Two of these components are arranged in series in a subassembly. The system reliability for the sub-assembly is:

- A. 0.90
- B. 1.80
- C. 0.81
- D. 0.99.

**Answer: C** ([LEAVE A REPLY](#))

As they are in series, System reliability =  $0.9 * 0.9 = 0.81$ . (Refer to item 96 above)

**NEW QUESTION: 989**

What is the tool and technique used to request seller responses?

- A. Procurement documents
- B. Expert judgment
- C. Bidder conferences
- D. Contract types

**Answer: C (LEAVE A REPLY)**

Section: Executing

**NEW QUESTION: 990**

You are a project manager working on a project installing an application for a hospital management system. Two months into the project, you conduct a review to determine how well the installer selected for this project is meeting goals for schedule, budget, and quality documented in the contract. Which of the followings tool will help you for this purpose?

- A. Performance reviews
- B. Audits Audits
- C. Inspection
- D. Expert judgment

**Answer: A (LEAVE A REPLY)**

**NEW QUESTION: 991**

In project management, a temporary project can be:

- A. A routine business process
- B. Completed without planning
- C. Ongoing to produce goods
- D. Long in duration

**Answer: D (LEAVE A REPLY)**

**Valid PMP Dumps** shared by PrepPdf.com for Helping Passing PMP Exam! PrepPdf.com now offer the **newest PMP exam dumps**, the PrepPdf.com PMP exam **questions have been updated** and **answers have been corrected** get the **newest** PrepPdf.com PMP dumps with Test Engine here: <https://www.preppdf.com/PMI/PMP-prepaway-exam-dumps.html> (2045 Q&As Dumps, **40%OFF Special Discount: Exam-Tests**)

**NEW QUESTION: 992**

Which of the following statements are true regarding bar charts?

- A. Bar charts are generally better at illustrating the resource tradeoffs compared with network diagrams
- B. Bar charts are generally better at illustrating critical paths compared with network diagrams
- C. Bar charts are generally better at illustrating progress or status compared with network diagrams

D. Bar charts are generally better at illustrating logical relationship compared with network diagrams

**Answer:** ([SHOW ANSWER](#))

**NEW QUESTION: 993**

The research and development (R&D) team has been working on developing a new software product for nine months and feel the product is now ready for release to the market and for final handover to the operations team. The operations manager asks the operations team to do a quick test and report the findings. The report highlights that there are many changes to this new product's interface of which the operations team was not aware. This will require new training. What should the project manager have done?

- A. Understood that the R&D and operations teams are two different entities and established a separate transfer project.
- B. Met with the operations manager and given the entire operations team a walk-through of the product beforehand.
- C. Included operations resources in the project to ensure knowledge transfer between the project and operations for implementation.
- D. Held two days of training to detail the changes and make the operations team comfortable with the changes.

**Answer:** A ([LEAVE A REPLY](#))

Section: Planning

**NEW QUESTION: 994**

In both the weak and strong matrix organizational structures, the primary condition leading to conflict is \_\_\_\_\_

- A. Communication barriers
- B. Conflicting interests
- C. Need for consensus
- D. Ambiguous jurisdictions

**Answer:** D ([LEAVE A REPLY](#))

Section: Mix Questions

Explanation:

Ambiguous jurisdictions exist when two or more parties have related responsibilities, but their work boundaries and role definitions are unclear. This situation is found frequently in weak and strong matrix organizations because of the "two-boss" concept.

**NEW QUESTION: 995**

Sharing good practices introduced or implemented in similar projects in the organization and/or industry is an example of:

- A. quality audits
- B. process analysis

C. statistical sampling

D. benchmarking

**Answer: D (LEAVE A REPLY)**

Section: Closing

**NEW QUESTION: 996**

The Work Breakdown Structure (WBS) is the basis for communicating:

A. Project scope, cost control, schedule, quality

B. Project objectives, dependencies, plan, cost control

C. Project scope, schedule, staffing, cost control

D. Project scope, quality, schedule, dependencies

E. Project budget, schedule, risk factors, work assignments.

**Answer: A (LEAVE A REPLY)**

**NEW QUESTION: 997**

A project manager is transferred to another country to perform a project within their organization. What should the project manager do first to ensure collaboration within the team for a successful delivery?

A. Determine a leadership style that is suitable for that location.

B. Assign a local resource to manage communication with the team.

C. Mentor the team members to perform project management.

D. Check if resources from headquarters can also be assigned to the project.

**Answer: A (LEAVE A REPLY)**

**NEW QUESTION: 998**

As a Project Manager, your first priority is to accomplish the work of the project. As a result of a project being complete, you have the opportunity to help those on the project become more educated on what worked well and what didn't on the project. What is the best answer for gaining this experience and knowledge?

A. Historical information

B. Assumptions

C. Lessons learned

D. Constraints

**Answer: C (LEAVE A REPLY)**

**NEW QUESTION: 999**

Your approved project schedule was based on resource leveling because of a scarcity of resources.

Management has now mandated that the project be completed as soon as possible. Which of the following methods will you use to recalculate the schedule?

A. Resource manipulation

- B. Reverse resource allocation
- C. Critical chain scheduling
- D. Resource reallocation

**Answer: (SHOW ANSWER)**

Section: Mix Questions

Explanation:

While resource leveling will often result in a project duration that is longer than the preliminary schedule as the original critical path probably will change and increase, it can also be used to get a schedule back on track by reassigning activities from noncritical to critical path activities.

**Valid PMP Dumps** shared by PrepPdf.com for Helping Passing PMP Exam! PrepPdf.com now offer the **newest PMP exam dumps**, the PrepPdf.com PMP exam **questions have been updated** and **answers have been corrected** get the **newest** PrepPdf.com PMP dumps with Test Engine here: <https://www.preppdf.com/PMI/PMP-prepaway-exam-dumps.html> (2045 Q&As Dumps, **40%OFF** Special Discount: **Exam-Tests**)